

Installation and Maintenance Manual

MRPW-04

Performa™ Winch

40.2 STP
40.2 STQP



HARKEN®

Introduction	3
Technical characteristics	3
<i>Performance data</i>	3
<i>Weight</i>	3
<i>Maximum working load</i>	3
Technical characteristics - Winch Quattro Performa	4
<i>Performance data</i>	4
<i>Weight</i>	4
<i>Maximum working load</i>	4
Outline	3
<i>Winch 40.2 STP</i>	3
Outline - Winch Quattro Performa	4
<i>Winch 40.2 STQP</i>	4
Installation	5
<i>Installation procedure</i>	6
<i>Positioning the self-tailing arm</i>	9
Maintenance	9
<i>Washing</i>	9
<i>Maintenance table</i>	9
<i>Disassembly procedure</i>	9
<i>Exploded view with maintenance products</i>	13
<i>Assembly</i>	14
Harken® limited worldwide warranty	15
Ordering spare parts	15
Exploded view	16
<i>Performa Winch 40.2 STP</i>	16
<i>Performa Winch 40.2 STQP</i>	18
Parts list	20
<i>Performa Winch 40.2 STP</i>	20
<i>Performa Winch 40.2 STQP</i>	21

Introduction

This manual gives technical information on winch installation and maintenance, including disassembling and reassembling.

This information is DESTINED EXCLUSIVELY for specialised personnel or expert users.

Installation, disassembling and reassembling of the winch by personnel who are not experts may cause serious damage to users and those in the vicinity of the winch.

Harken® accepts no responsibility for defective installation or reassembly of its winches.

In case of doubt the Harken® Tech Service is at your disposal at techservice@harken.it

This Manual is available only in English. If you do not fully understand the English language, do not carry out the operations described in this Manual.

Technical characteristics

	Power ratio	Gear ratio
1st speed	13,50 : 1	2,13 : 1
2nd speed	39,90 : 1	6,28 : 1

The theoretical power ratio does not take friction into account.

Weight

	ST Version
Weight (Kg)	3,8

Maximum working load



WARNING!

The maximum working load (MWL) for the 40.2 ST Performa™ Winch is 850Kg (1874 lb). Subjecting the winch to loads above the maximum working load can cause the winch to fail or pull off the deck suddenly and unexpectedly during high loads causing severe injury or death.

Outline

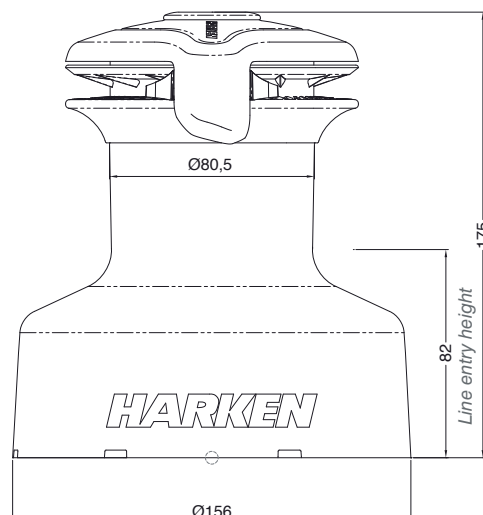

Technical characteristics - Winch Quattro Performa

Dual Drum Winch: upper drum and lower drum.

LD refers to the lower drum

See Outline for dimensions

	Power ratio	Power ratio LD	Gear ratio
1st speed	13,50 : 1	7,03 : 1	2,13 : 1
2nd speed	39,90 : 1	20,72 : 1	6,28 : 1

The theoretical power ratio does not take friction into account.

Weight

	ST
weight (Kg)	4,6

Maximum working load



WARNING!

The maximum working load (MWL) for the 40.2 STQP Performa™ Winch is 850 Kg (1874 lb).

The maximum working load (MWL) for the 40.2 STQP Performa™ Winch relative to the lower drum is 350 Kg (772 lb).

Subjecting the winch to loads above the maximum working load can cause the winch to fail or pull off the deck suddenly and unexpectedly during high loads causing severe injury or death.

Outline

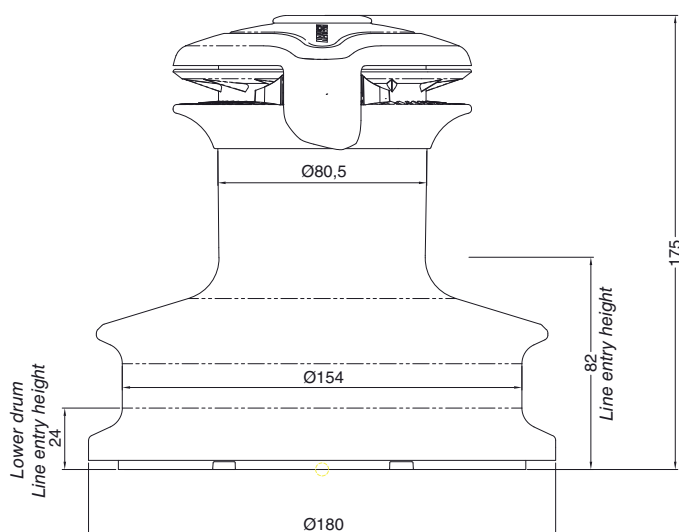

Installation

The winch must be installed on a flat area of the deck, reinforced if necessary to bear a load equal to at least twice the maximum working load of the winch.

It is the installer's responsibility to carry out all structural tests needed to ensure that the deck can bear the load.

Harken® does not supply the screws needed to install the winch since these may vary depending on the deck on which it is to be installed.

It is the installer's responsibility to choose the correct screws taking account of the loads they will have to bear.

Harken® assumes no responsibility for incorrect installation of its winches or for an incorrect choice of mounting screws.



DANGER!

Incorrect installation of the winch may cause severe injury or death. Consult the yard that built the boat in the case of doubt over the correct positioning of the winch.



WARNING!

Failure to use the correct number and type of mounting fasteners or failure to ensure the correct deck strength can result in the winch pulling off the deck suddenly and unexpectedly during high loads causing severe injury or death.



WARNING!

Verify the entry angle of the sheet. This must be 8° with tolerance of $\pm 2^\circ$, to avoid sheet overrides and damaging the winch or making the winch inoperable leading to loss of control of the boat which can lead to severe injury or death.

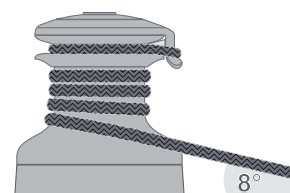

WARNING!

Mount the winch on the deck so that the drive gear is positioned where the sheet enters the winch drum. Incorrect position of drive gear can weaken winch leading to failure which can cause an accident leading to severe injury or death.

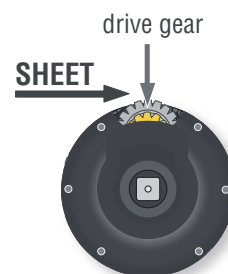

Once you have chosen the correct mounting position for the winch on the deck proceed with installation.

Procedure

To install the winch you must remove the drum and use Socket Head (SH) bolts.

Tools needed

 One medium flat-bladed screwdriver

To identify the various parts, refer to the exploded view at the end of this Manual.

 Torque to apply when assembling



1. Unscrew the central screw ( 2Nm/18 in-lb)



2. Slide off the socket n°25 and the cover n°26



3. Unscrew the three screws n°24
( 4Nm/35 in-lb)



4. Remove the stripper arm n°28 by rotating and lifting it.



5. Lift off the drum n°21

Install the winch on the deck in the position you have chosen, keeping in mind the limits described on page 3. (See paragraph on installation)

Installation procedure

Carry out the **Procedure**, then install the winch on the deck in the chosen position.

- A.** Position the base of the winch on the deck and mark the position of the holes or use the drilling cut-out template at the point where you have decided to place the winch.

Below is a reduced scale diagram.

The drilling cut out template is available on the Harken® website, www.harken.com

Winch STP

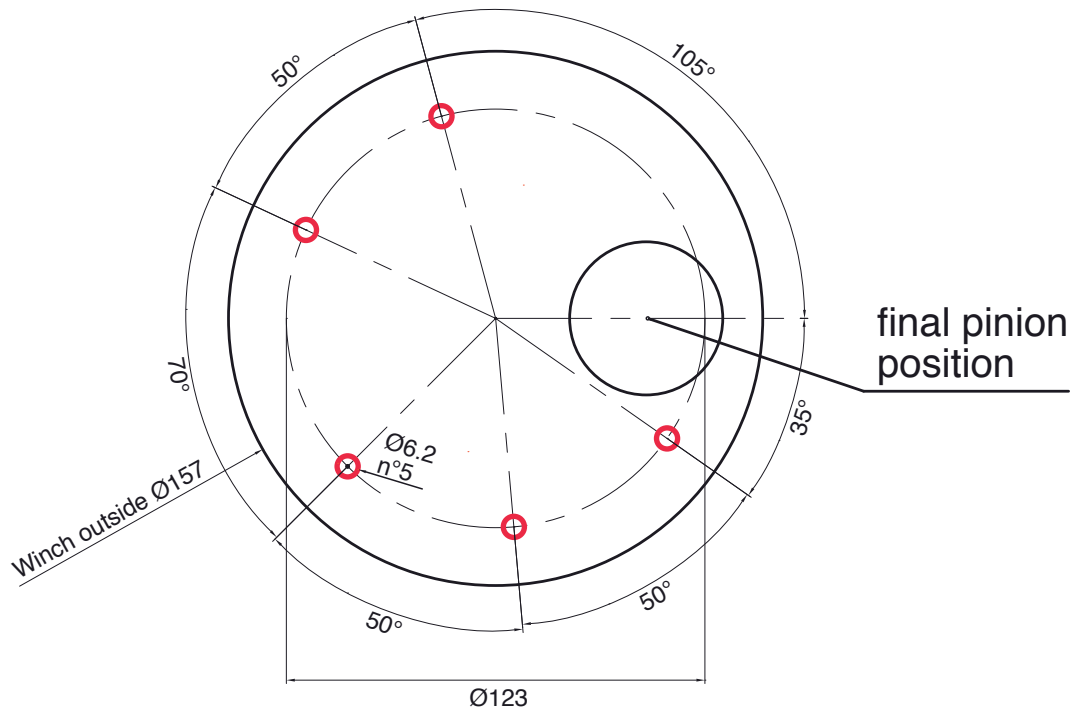

Winch STQP

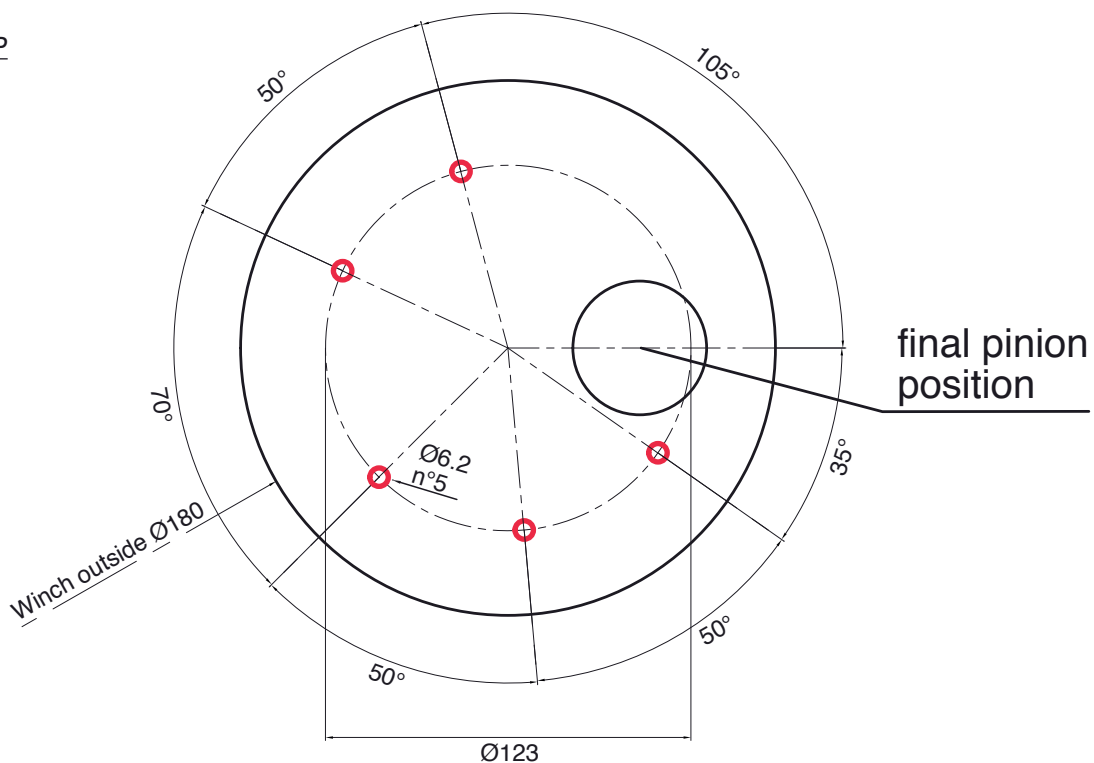

- B.** Remove the winch and drill the five 6.2 mm diameter holes.
- C.** Bolt the base of the winch to the deck using five M6 Socket Head (SH) bolts (not supplied by Harken®), correctly chosen for the thickness and type of the boat deck. Consult the yard that built the boat in case of doubt.

**WARNING!**

To install the winch on the deck, use only bolts in A4 stainless steel (DIN 267 part11). Bolts made of other materials may not have sufficient strength or may corrode which can result in winch pulling off deck suddenly and unexpectedly during high loads causing severe injury or death.

NOTICE

To mount winches on the deck, do not use countersunk bolts.

- D.** Fill the mounting holes with a suitable marine sealant.
- E.** Remove the excess adhesive/sealant from the holes and base drainage channels
- F.** Reassemble the winch following the steps of the **Procedure** in the reverse order, and apply the products indicated in the section on maintenance.

NOTICE

Before closing the winch, make sure the holes and drainage channels in the base of the winch are not obstructed.

Positioning the self-tailing arm

Position the self-tailing arm so that the line leaving the winch is led into the cockpit.

Maintenance

Washing

Winches must be washed frequently with fresh water, and in any case after each use.

Do not allow teak cleaning products or other cleaners containing caustic solutions to come into contact with winches and especially anodised, chrome plated or plastic parts.

Do not use solvents, polishes or abrasive pastes on the logos, on the stickers on the winches or on any anodized, chrome plated and plastic surfaces.

Make sure that the holes and drainage channels in the base of the winch are not obstructed so that water does not collect.

Maintenance table

Winches must be visually inspected at the beginning and end of every season of sailing or racing.

In addition they must be completely overhauled, cleaned and lubricated at least every 12 months.

After an inspection, replace worn or damaged components. Do not replace or modify any part of the winch with a part that is not original.



WARNING!

Periodic maintenance must be carried out regularly. Lack of adequate maintenance shortens the life of the winch, can cause serious injury and also invalidate the winch warranty.

Installation and maintenance of winches must be carried out exclusively by specialized personnel.

In the case of doubt contact Harken® Tech Service at techservice@harken.it

Disassembly procedure

Tools needed



One medium flat-bladed screwdriver

A number five hex key



Rags

To identify the various parts refer to the exploded view at the end of this Manual.

 Torque to be applied in assembly phase

Carry out procedure as shown in the paragraph on winch installation and then do the following:



6. Completely unscrew the three screws n° 24



7. Remove the stripper arm support n° 20



8. Slide out the central shaft n° 18



9. Unscrew the 6 hex screws n° 15
($\approx 8\text{Nm}/71\text{ in-lb}$)



10. Remove the drum housing n° 14
Important: washer n° 11 may remain
inside the drum support!



11. Remove washer n° 11



12. Remove gear n°6 and remove the pawls n°4. To facilitate the operation press the spring against the pawl with a blade.



13. Slide off gear n°2



14. Slide off gear n°13



15. Remove pin n°7



16. Slide off gear n°9



17. Remove the pawls n°4. To facilitate the operation press the spring against the pawl with a blade.

If it is necessary to replace any **jaws** of the winch, proceed as follows:



I. Unscrew the 4 screws n°23
($\approx 4\text{Nm}/35\text{ in-lb}$)



II. Remove the jaws n°22

Inspect balls inside the drum and carefully check the correct position; if it is necessary to put back any balls, push balls in the race (as shown below):



Once the winch is completely disassembled, clean the parts: use a basin of diesel oil to soak metal components and rinse plastic parts in fresh water. Once you have done this, dry the parts with cloths that do not leave residue.

Inspect gears, bearings, pins and pawls for any signs of wear or corrosion.

Carefully check the teeth of gears and ring gears to make sure there are no traces of wear.

Check the roller bearings and check there are no breaks in the bearing cages.
Replace worn or damaged components.

Carry out maintenance on components using the products listed below.

For more information on which products to use where, refer to the exploded diagram below.

Use a brush to lightly lubricate all gears, gear pins, teeth and all moving parts with grease.
Lightly lubricate the pawls and springs with oil. Do not use grease on the pawls!

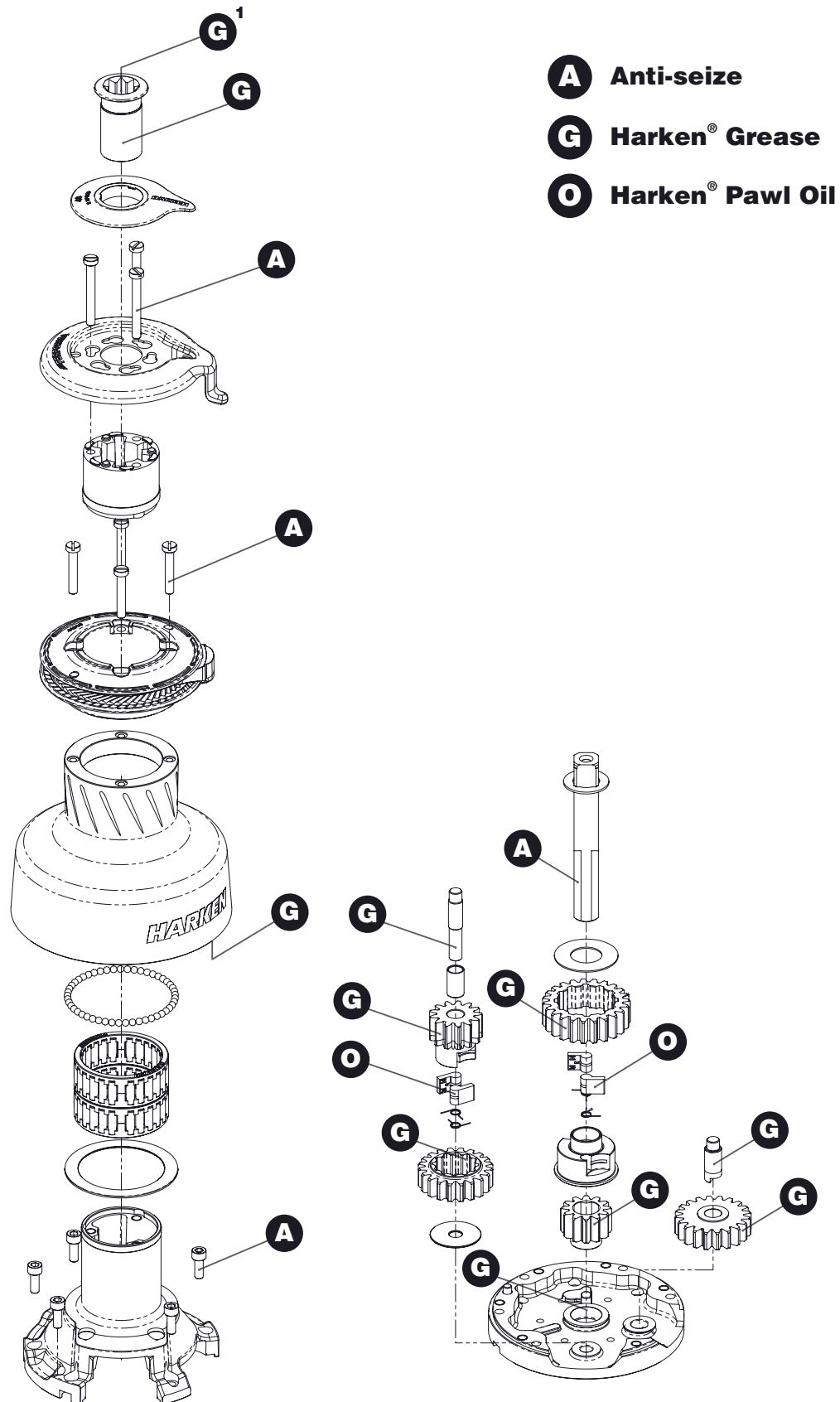
Exploded view with maintenance products

¹Apply Harken® grease on assy socket screw

Assembly

Make sure that the holes and drainage channels in the base of the winch are not obstructed. Assemble the winch in the reverse order of the sequence in the section on disassembly.

To tighten bolts, use the torque indicated in the disassembly procedure.



If the jaws have been disassembled, insert peeler between the two jaws, taking care that the letters TOP on the peeler are facing upwards.



When positioning the stripper arm, align the peeler with it.

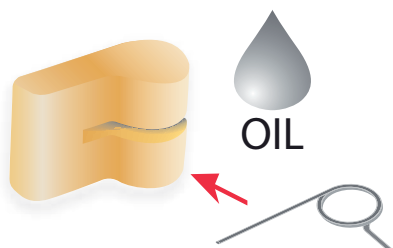

To assemble the pawls:

correctly position the spring in its housing as shown at left. Hold the spring closed and slide the pawl into its housing. Once in position, check that the pawls can be easily opened and closed with a finger.

In case of doubt concerning the assembly procedure contact Harken® Tech Service: techservice@harken.it

Harken® limited worldwide warranty

Refer to the Harken® Limited Worldwide Warranty in the Harken® Catalogue and on the website www.harken.com

Ordering spare parts

Spare parts can be requested from Harken® as described in the Harken® Limited Worldwide Warranty, indicating the part number in the Parts List and including the serial number of the winch for which the parts are required.

The serial number of the winch is printed on a plate on the drum support of the winch.

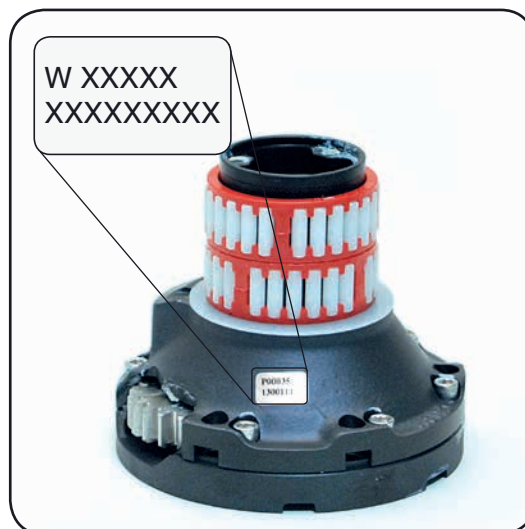

Manufacturer

Harken® Italy S.p.A.

Via Marco Biagi, 14
22070 Limido Comasco (CO) Italy
Tel: (+39) 031.3523511
Fax: (+39) 031.3520031
Email: info@harken.it
Web: www.harken.com

- **Tech Service**
Email: techservice@harken.it
- **Customer Service**
Tel: (+39) 031.3523511
Email: info@harken.it

Headquarters

Harken®, Inc.

1251 East Wisconsin Avenue
Pewaukee, Wisconsin 53072-3755 USA
Tel: (262) 691.3320
Fax: (262) 691.3008
Email: harken@harken.com
Web: www.harken.com

- **Tech Service**
Email: technicalservice@harken.com
- **Customer Service**
Tel: (262) 691-3320
Email: customerservice@harken.com

Exploded view 1/2



Performa Winch 40.2 STP

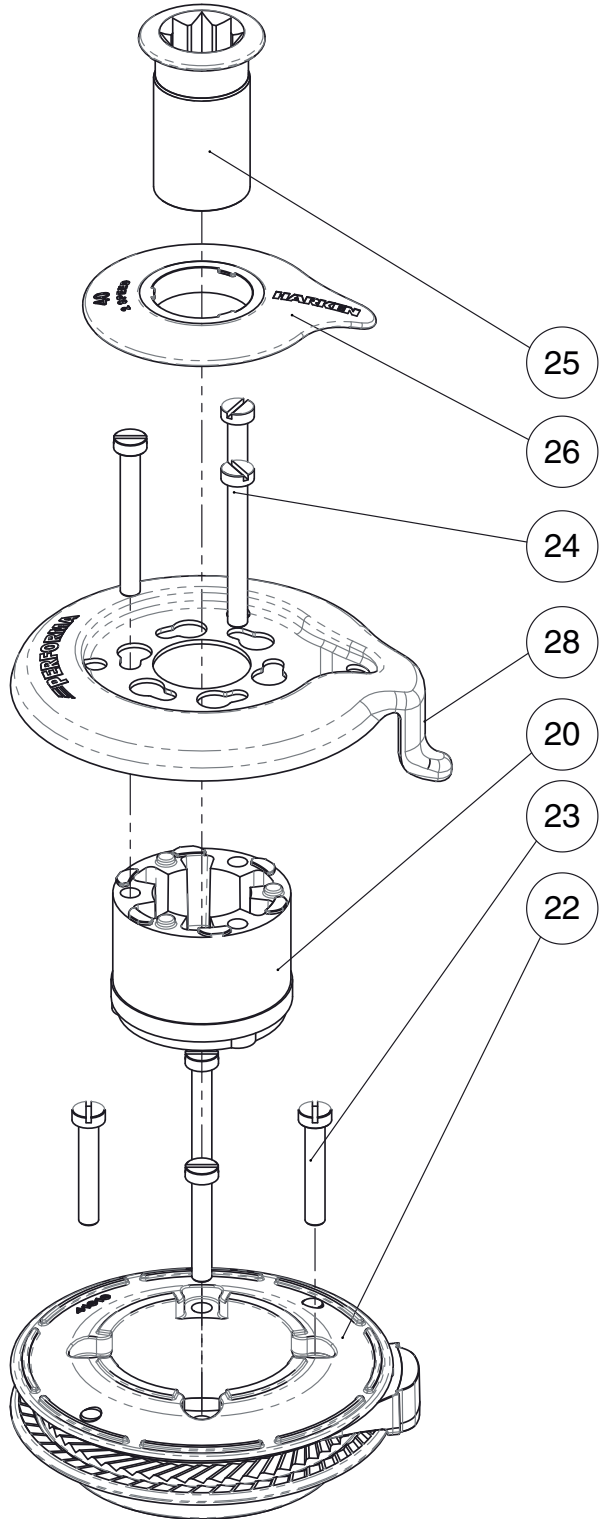
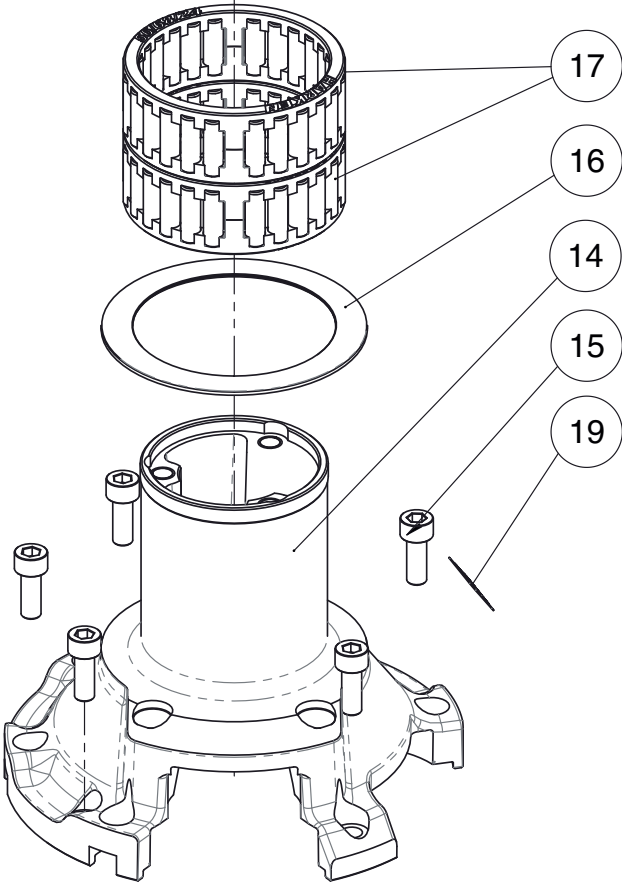
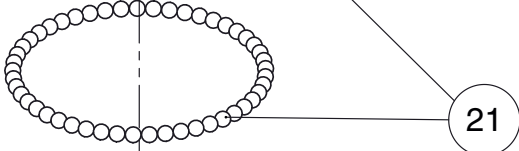
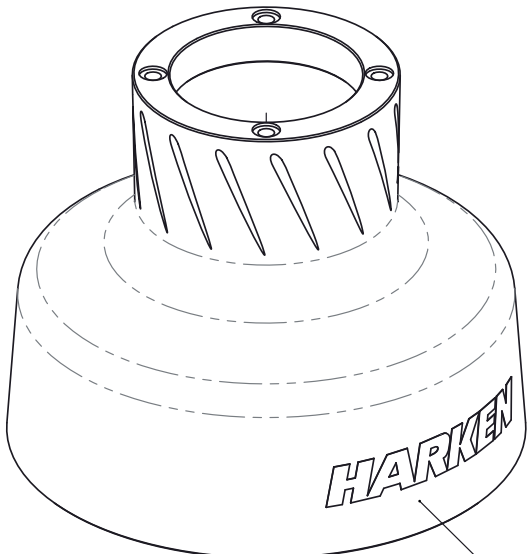

Exploded view 1/2



Performa Winch 40.2 STQP

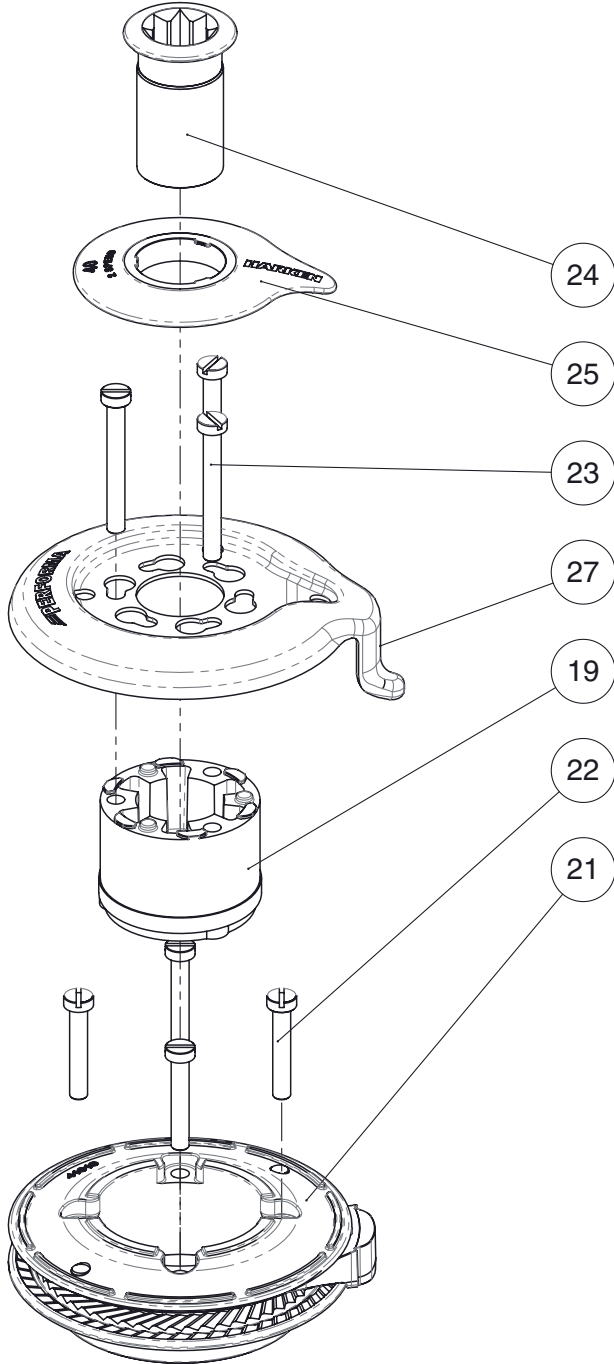
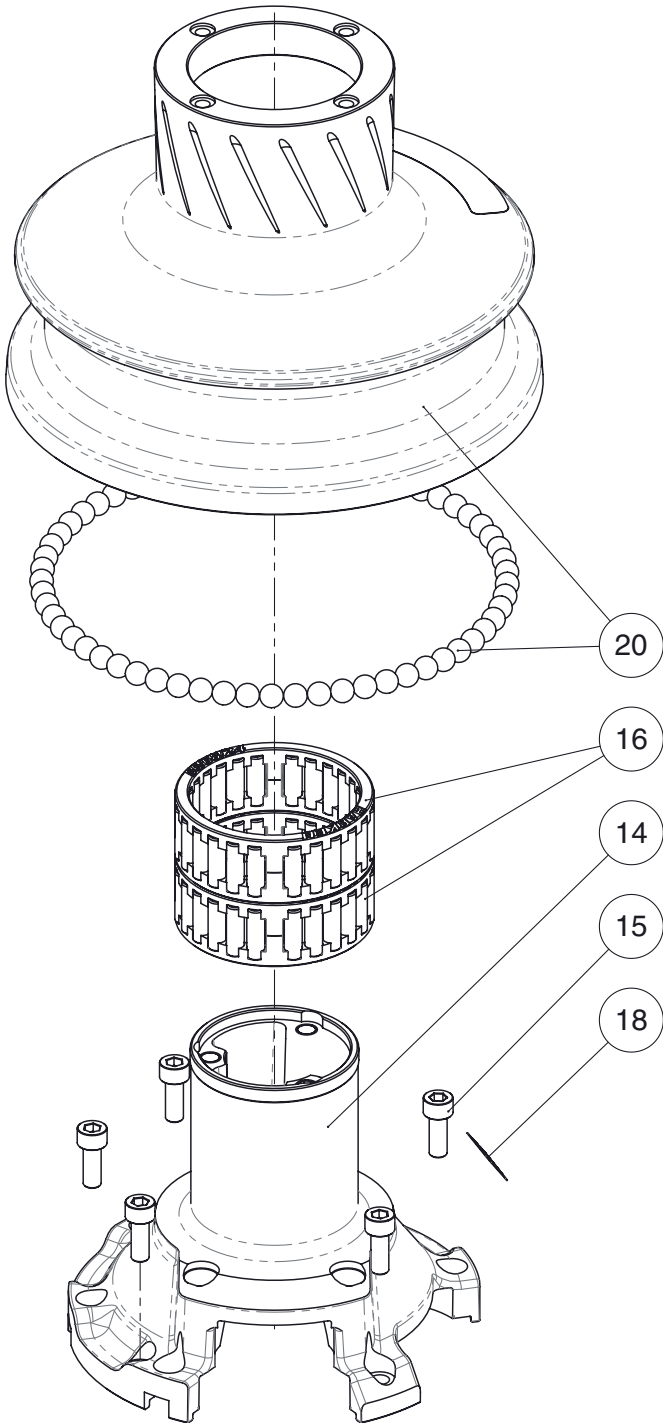

Performa Winch 40.2 STQP

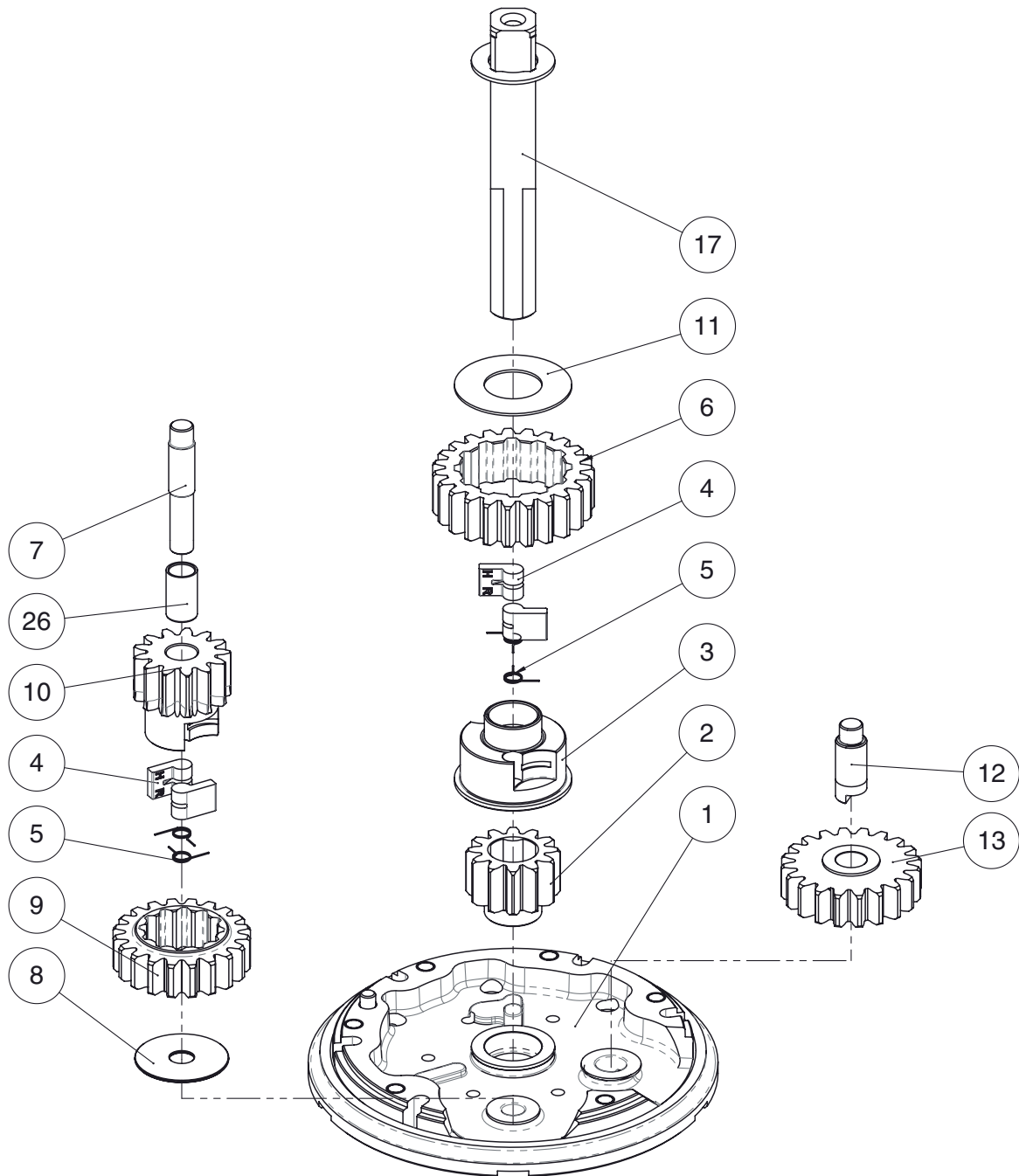

Performa Winch 40.2 STP

Pos	Q.ty	Code	Description	Pos	Q.ty	Code	Description
1	1	A96633200	PERFORMA Winch 40 Base Assy <i>PERFORMA Base W40</i> <i>Heli-coil M6x9</i>	17	2	A74136000	Bearing Ø56xØ68x24
	1	S413350080	<i>Roller Ø6x19</i>	18	1	A94139000	Assy Central Shaft W35/40 <i>Central shaft W35/40 ST</i>
	1	S4152300A7	<i>Bushing Ø22xØ25x9.5</i>		1	S413880002	<i>Washer Ø17.2xØ32x1.5</i>
	1	S413960085	<i>Bushing Ø9xØ11x12</i>	19	1		Winch Serial Number Sticker
	1	S413330085	<i>Bushing Ø12xØ14x11</i>	20	1	S4129400A0	Stripper arm support
2	1	S413020004	Gear Z12	21	1	A96572600	Performa Drum W40 <i>Performa Drum W40</i>
3	1	S413030004	Pawls Carrier Ø8xN2				<i>Winch Product Sticker**</i>
4	4	S000090004	Pawl Ø8*		1	S6572700A3	<i>Bearing ring W40</i>
5	4	S000380001	Pawl Spring Ø8*		49	M0619580	<i>Ball 3/16"</i>
6	1	S412830041	Gear Z23	22	1	A94131800	Assy Winch 40 Jaws <i>Lower Jaw W35/40</i>
7	1	S657380004	Performa Pin Ø9-10 W40				<i>Upper Jaw W35/40</i>
8	1	S279090002	Washer 36x9,5x1		1	S413610080	<i>Peeler W20 - 40</i>
9	1	S412970004	Gear Z20		4	S385970001	<i>SPRING</i>
10	1	S657370041	Performa Pinion Z13 W40	23	4	M0601803	Screw UNI EN ISO 1207:1996 - M6x35 - A4
11	1	S413120002	Washer Ø22.5xØ45x1	24	3	M6007103	Screw M6x50 UNI6107
12	1	S413070004	Pin Ø9xØ12x32.5	25	1	A94136400	Assembly Socket W20-80 <i>Socket Handle W20/80</i>
13	1	A94130500	Assy Gear Z20 <i>Gear Z20</i>		1	S415130085	<i>Washer Ø7.7xØ25x5.8</i>
	2	S414900080	<i>Bushing Ø12xØ14x8</i>		1	M0614303	<i>Screw M8x20 UNI 6109</i>
14	1	A94141500	Assy Housing Winch 40 <i>Support W40</i>	26	1	S4141900A5	Cover 2 speed W40
	2	S414890080	<i>Bushing Ø9xØ11x7</i>	27	1	M6033794	Bushing XSM-1012-20
	3	M0649802	<i>Heli-coil M6x9</i>	28	1	S657360019	Performa Black Stripper Arm W40
	1	S4130900A7	<i>Bushing Ø22xØ25x8.5</i>				
15	6	M0635103	Socket head screw M6x16 UNI 5931				
16	1	S657280052	Performa Shim W40				

*Available with service kit; see website www.harken.com

**Winch product sticker



Performa Winch 40.2 STQP

Pos	Q.ty	Code	Description	Pos	Q.ty	Code	Description
1	1	A94163400	Assembly base W40Q with thrust bearing <i>Ring base W40 STQ</i> <i>Base W40</i> <i>Heli-coil M6x9</i>	17	1	A94139000	Assembly Central Shaft W35/40 <i>Central shaft W35/40 ST</i>
	1	S413350080	<i>Roller Ø6x19</i>		1	S413880002	<i>Washer Ø17.2xØ32x1.5</i>
	1	S4152300A7	<i>Bushing Ø22xØ25x9.5</i>	18		Winch Serial Number Sticker	
	1	S413960085	<i>Bushing Ø9xØ11x12</i>	19	1	S4129400A0	Stripper arm support
	1	S413330085	<i>Bushing Ø12xØ14x11</i>	20	1	A94163201	Assembly Performa Drum W40 Q <i>Performa Drum W40 Q</i>
2	1	S413020004	Gear Z12	61	M0610280	<i>Ball 5/16"</i> <i>Winch STQ product sticker**</i>	
3	1	S413030004	Pawls Carrier Ø8xN2	21	1	A94131800	Assembly Winch 40 Jaws <i>Lower Jaw W35/40</i> <i>Upper Jaw W35/40</i>
4	4	S000090004	Pawl Ø8*		1	S413610080	<i>Peeler W20 - 40</i>
5	4	S000380001	Pawl Spring Ø8*		4	S385970001	<i>SPRING</i>
6	1	S412830041	Gear Z23		22	4	M0601803
7	1	S657380004	Performa Pin Ø9x10 W40	23	3	M6007103	Screw M6x50 UNI6107
8	1	S279090002	Washer Ø36xØ9,5x1	24	1	A94136400	Assembly Socket W20-80 <i>Socket Handle W20/80</i>
9	1	S412970004	Gear Z20	1	S415130085	<i>Washer Ø7.7xØ25x5.8</i>	
10	1	S657370041	Performa Pinion Z13 W40	1	M0614303	<i>Screw M8x20 UNI 6109</i>	
11	1	S413120002	Washer Ø22.5xØ45x1	25	1	S4141900A5	Cover 2 speed W40
12	1	S413070004	Pin Ø9xØ12x32.5	26	1	M6033794	Bushing XSM-1012-20
13	1	A94130500	Assembly Gear Z20 <i>Gear Z20</i>	27	1	S657360019	Performa Black Stripper Arm W40
	2	S414900080	<i>Bushing Ø12xØ14x8</i>				
14	1	A94141500	Assembly Housing Winch 40 <i>Support W40</i> <i>Heli-coil M6x9</i>				
	2	S414890080	<i>Bushing Ø9xØ11x7</i>				
	1	S4130900A7	<i>Bushing Ø22xØ25x8.5</i>				
15	6	M0635103	Socket head screw M6x16 UNI 5931				
16	2	A74136000	Bearing Ø56xØ68x24				

*Available with service kit; see website www.harken.com

**Winch product sticker

