

HARKEN®

ESP JIB REEFING & FURLING

Unit 2, 3

Installation Manual – Intended for specialized personnel or expert users

5003 05/19



Preassembly

Safety precautions/parts descriptions	2 – 3
Specifications	3
Parts list	4 – 6
Tools	6
Top foil	7 - 8
Toggle deductions/stay into foil	9
Confirm foil length	10
Cutting/drilling top foil	11 - 12

Assembly

Foils/connectors/halyard deflector	13 – 17
Halyard swivel	17
Drum assembly	17 – 18
Leg kit with toggle assembly	19 – 21
Final	22

Commissioning

Line to cockpit/line on drum assembly	23 – 24
Storm sails	24
Raise sail	25
Check halyards	26

Operation

Check halyards	27
Furl/reef	28 – 29
Secure sail	29
Adjust turnbuckle	30

Maintenance

Clean/inspect	31
Storage	31

Troubleshoot 32

Product registration 32

Online warranty/product registration 32

Appendix

Dimensions/sailmaker's instructions	33
Parts lists, Unit 2 and Unit 3	34-35

Please read these instructions carefully before installing, servicing, or operating the equipment. This manual may be modified without notice. See www.harken.com/manuals for updated versions.

PLEASE SAVE THESE INSTRUCTIONS

Parts Description

Introduction

This manual gives technical information on installation and service. This information is **destined exclusively** for specialized personnel or expert users. Installation, disassembling, and reassembling by personnel who are not experts may cause serious damage to property or injury to users and those in the vicinity of the product. If you do not understand an instruction contact Harken.

The user must have appropriate training in order to use this product.

Harken accepts no responsibility for damage or harm caused by not observing the safety requirements and instructions in this manual. See limited warranty, general warnings, and instructions in www.harken.com/manuals.

Purpose

Harken Jib Reefing and Furling is designed for rolling sails on sailboats to reduce sail size or to completely roll so wind has little effect on the sail. Use of this product for other than normal sailboat applications is not covered by the limited warranty.

Safety Precautions



WARNING! This symbol alerts you to potential hazards that may kill or hurt you and others if you don't follow instructions. The message will tell you how to reduce the chance of injury.



CAUTION! This symbol alerts you to potential hazards that may hurt you and others if you do not follow instructions. The message will tell you how to reduce the chance of injury.



WARNING! Strictly follow all instructions to avoid potential hazards that may kill or hurt you and others. See www.harken.com/manuals for general warnings and instructions.

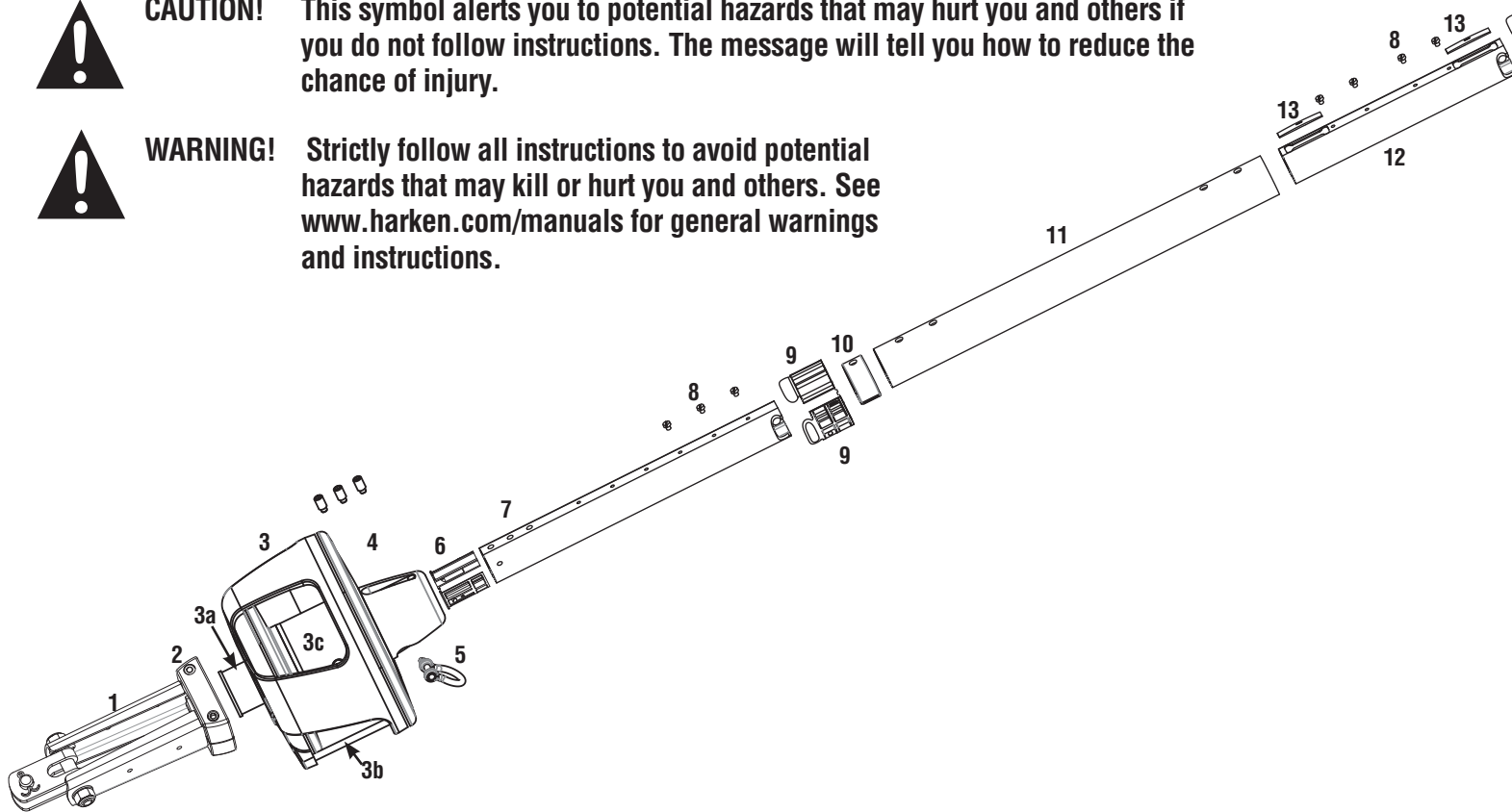

Parts Descriptions

1. Leg kit with toggle	4. Adjuster tube clamp screws	10. Feeder	15. Halyard swivel
2. Leg kit collar	5. Bow shackle	11. Foil (2 m)	16. Trim cap screws
3. Drum assembly	6. Adjuster tube bushings	12. Connector	17. Trim cap
a. Neck	7. Adjuster tube	13. Connector wedge	
b. Guard posts	8. Foil screws	14. Top foil	
c. Spool	9. Connector bushings	a. Trim cap holes	

Online product registration
www.harken.com/FurlingWarranty

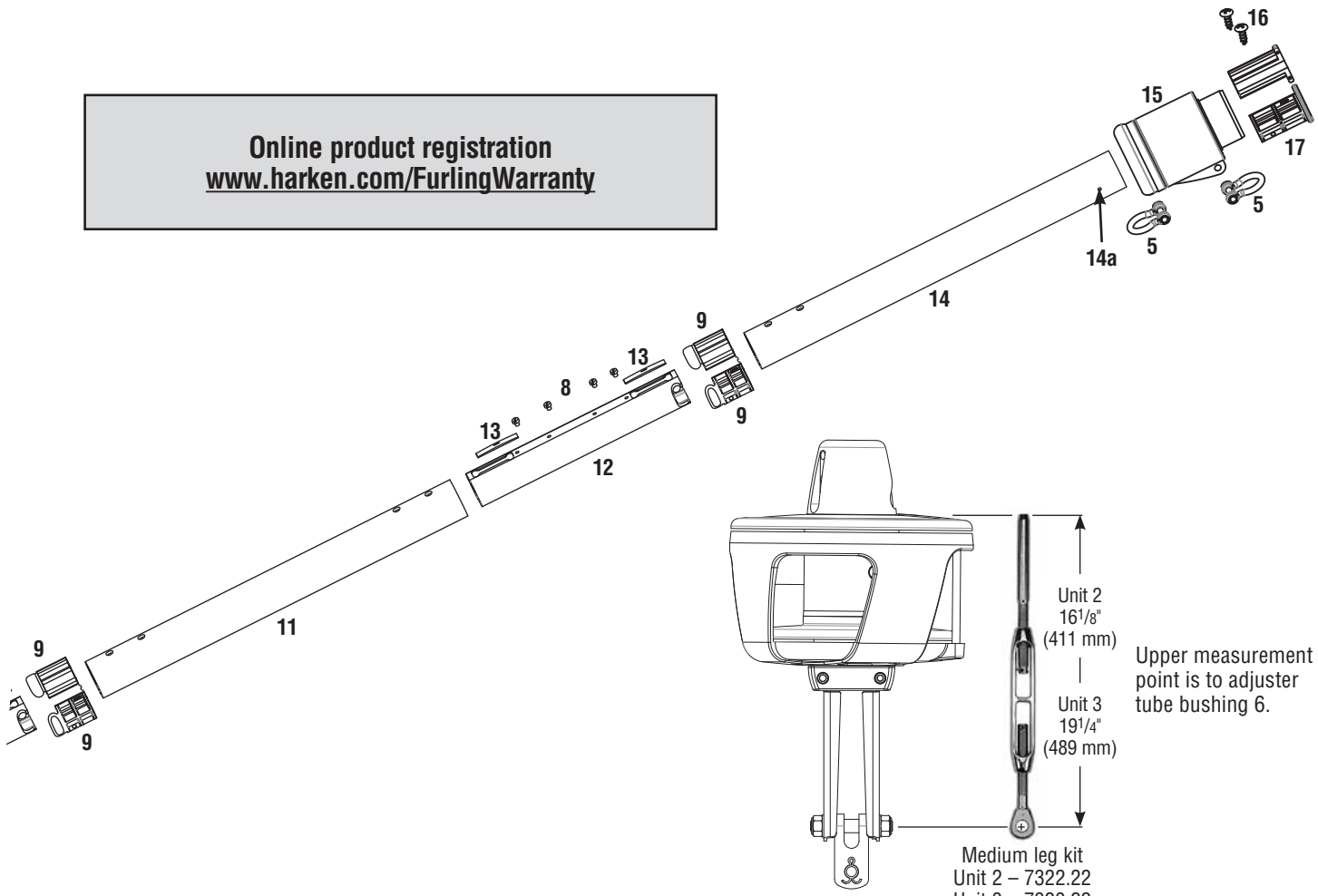

Medium leg kit
 Unit 2 – 7322.22
 Unit 3 – 7323.22
 Max turnbuckle length

1) Leg Kit with toggle assembly

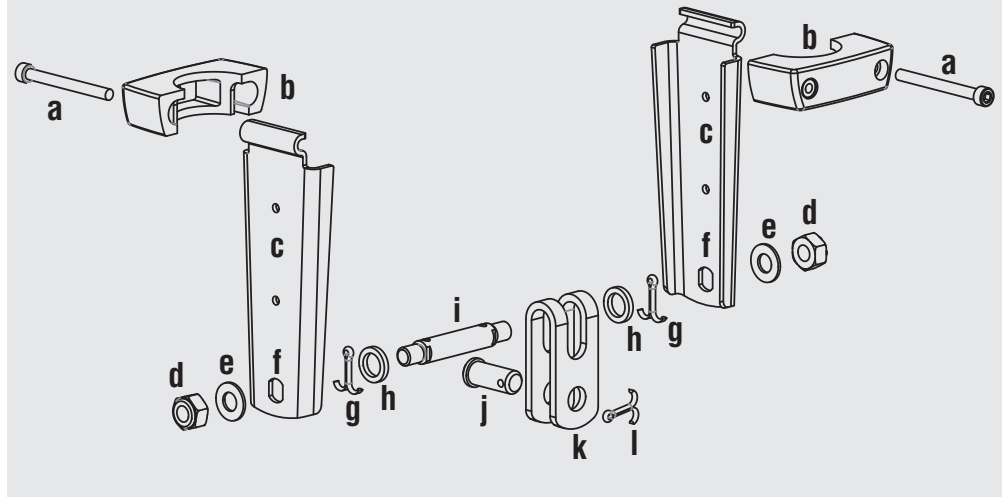

- a. Leg kit collar screw
- b. Collar
- c. Short, medium or long keg
- d. Lock nut
- e. Washers
- f. Flat hole in plate
- g. Cotter pin
- h. Spacer
- i. Threaded cross pin
- j. Clevis pin
- k. Jaw/jaw toggle
- l. Cotter pin

Unit 2, 3 short, medium, and long

Unit Part Numbers

Unit	Unit without lower toggle	Leg kit with toggle assembly – short	Leg kit with toggle assembly – medium	Leg kit with toggle assembly – long	Clevis pin Ø	Wire Ø	Rod sizes
2	7322.10	7322.20	7322.22	7322.21	5/8", 3/4" (15.9, 19.1 mm)	5/16", 3/8", 7/16" (8, 10, 12 mm)	-12 -17, -22 (7.14, 8.38, 9.53 mm)
3	7323.10	7323.20	7323.22	7323.21	7/8", 1" (22.2, 25.4 mm)	1/2", 9/16", 5/8" (12.7, 14, 16 mm)	-22, -30, -40 (9.53, 11.10, 12.7 mm)

Note: When using a turnbuckle you must use a medium or long leg kit assembly. *Check max turnbuckle length above.



Halyard swivel

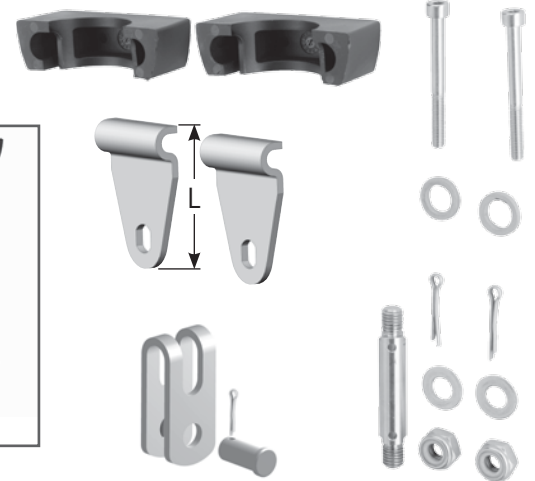
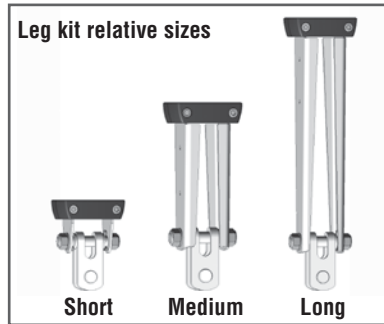

Short leg kit
DO NOT USE with turnbuckle



Drum assembly

Adjuster tube clamp screws

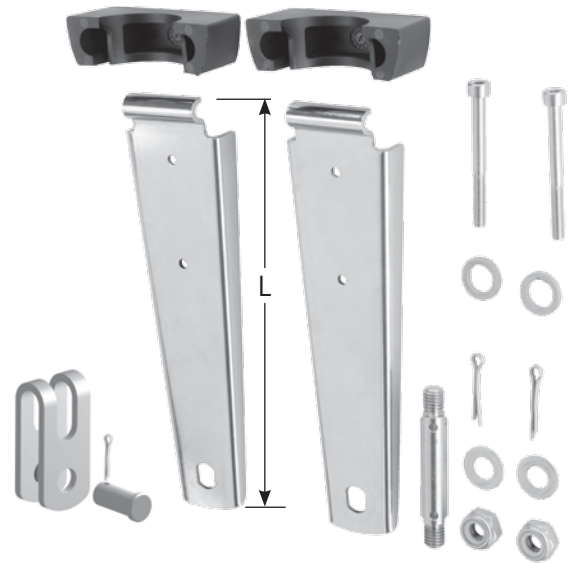

Medium or long leg kit
Required for installation with turnbuckle



Bow shackles



Blue Loctite®

Loctite is a trademark of Henkel AG & Company KGaA

Drum Box

Description	Unit 2				Unit 3			
	Part No.	Size	Length* (L)	Qty	Part No.	Size	Length* (L)	Qty
Halyard swivel	H-56229	—	—	1	H-57148	—	—	1
Drum assembly	7322.10BASE	—	—	1	7323.10BASE	—	—	1
Bow shackles	2117	8 mm	—	3	2124	10 mm	—	3
Short leg kit with toggle	7322.20	5/8", 3/4"	3 1/4" (264 mm)	1	7323.20	7/8", 1"	4" (99 mm)	1
Medium leg kit with toggle	7322.22	5/8", 3/4"	10 1/2" (264 mm)	1	7323.22	7/8", 1"	12 1/2" (320 mm)	1
Long leg kit with toggle	7322.21	5/8", 3/4"	15" (378 mm)	1	7323.21	7/8", 1"	18 1/4" (466 mm)	1
Adjuster tube clamp screws	HFS1252	8 mm	—	4	HFS1252	8 mm	—	5
Blue Loctite®	833	—	—	1	833	—	—	1

* Lengths are approximate to distinguish between short, medium and long.

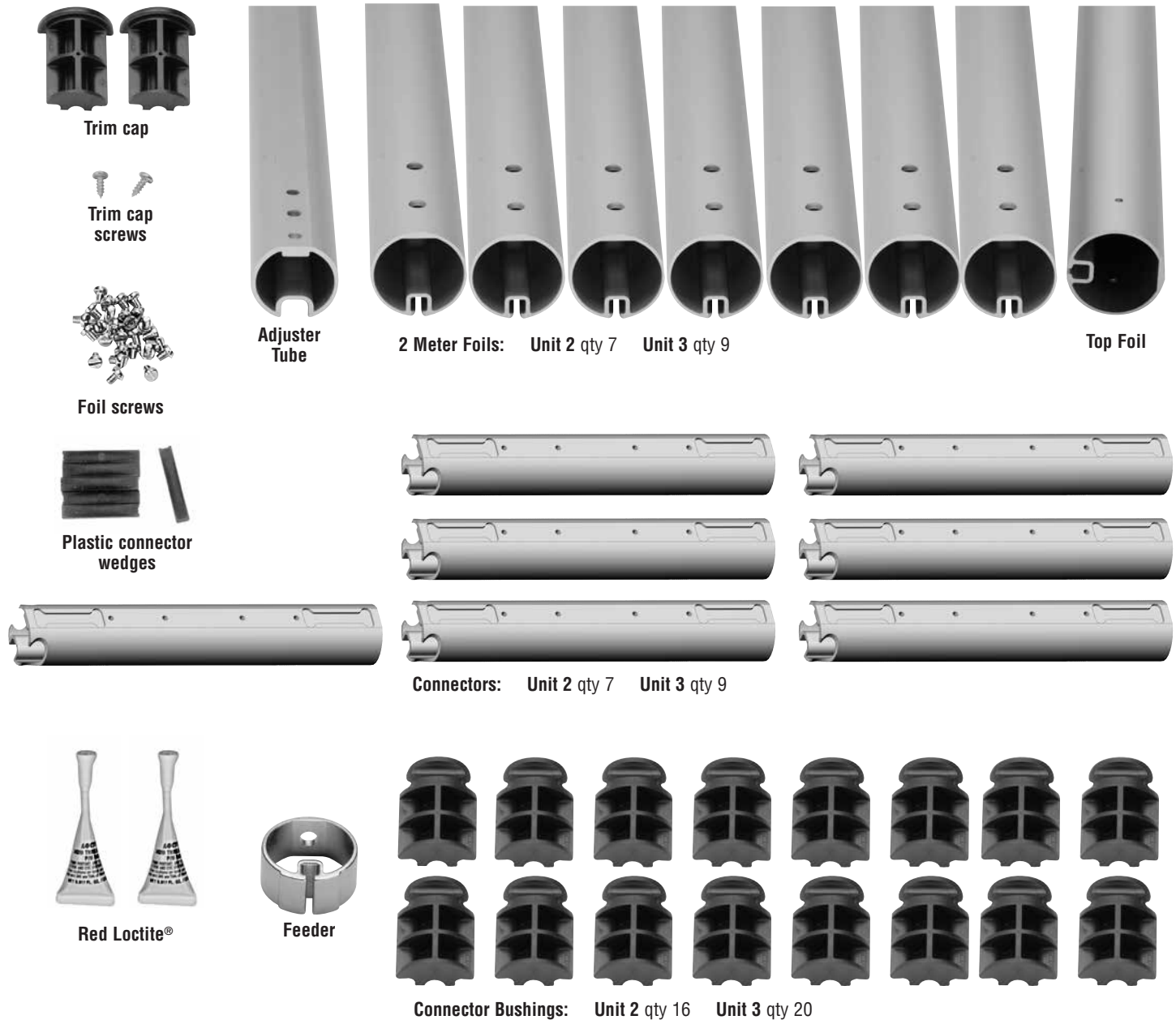

Foil Set

Description	Unit 2		Unit 3	
	Part	Qty	Part	Qty
Included				
Trim cap	H-55977	2	H-57123	2
Trim cap screws	HFS1127	2	HFS1127	2
Adjuster tube	7322.33	1	7323.33	1
Foils (2 m)	7322.30	7	7323.30	9
Top foil	7322.34 2000	1	7323.34 2000	1
Foil screws	HFS385	39	HFS383	47
Connectors	H-59991	7	H-60149	9
Connector bushings	H-55901	16	H-57122	20
Connector wedges	MP-1894	16	MP-1894	20
Feeder	H-55905	1	H-57110	1
Adjuster tube bushing	MP-1977	2	MP-1978	2
Red Loctite®	HFG739	2	HFG739	2
Order Separately				
Extra foil (see pages 7 - 8)	7322.30	1	7323.30	1
Extra connector with bushings	7322.31	1	7323.31	1



Required parts sold separately by Harken:

- Extra foil and connector if required. See pages 7 - 8.
- Harken short leg kit with toggle. Do not use with turnbuckle.
- Harken medium or long leg kit with toggle. Required for turnbuckle.
- Rod rigging requires Harken rod adapter stud.
- Furling line except Unit 3. To purchase elsewhere, figure length required:
Boat length + foot length of largest sail + 6' (1.8 m).



WARNING! Wire that is old or damaged may break suddenly, causing an accident. Headstay condition should be checked by a professional rigger before reusing.

Optional parts, sold separately by Harken:

- Halyard deflector. Use when halyard exits very close to stay attachment point.
- 7404 Lead block kit and one additional 7403 if necessary. Fits 1" (25 mm) stanchions.

Required Parts

Short leg kit with toggle Do not use with turnbuckle			Medium leg kit with toggle Required for turnbuckle			Long leg kit with toggle Required for turnbuckle		
Unit	Part No.	Clevis Pin	Part No.	Clevis Pin	Part No.	Clevis Pin		
2	7322.20	5/8, 3/4	7322.22	5/8, 3/4	7322.21	5/8, 3/4		
3	7323.20	7/8, 1	7323.22	7/8, 1	7323.21	7/8, 1		



Optional Parts

7404 Lead block kit
Includes 3 x 7403; 1 x 7401; 1 x 7402; 1 horn cleat

Unit	Part No.
2	7303
3	7304

Rod rigging: Harken rod adapter stud required

Rod Size	Thread Size UNF	Part No.
-12 7.14 mm	5/8"	7421 -6
-17 8.38 mm	5/8"	7425 -17
-22 9.53 mm	3/4"	7426 -22
-30 11.10 mm	7/8"	7427 -30



Furling line

Unit	Part No.	Line Ø	Length (ft)
2	HFG235	8 mm	100
3	*	12 mm	See Above

*Not available from Harken

Preassembly

Unit	Size
1	6 mm
3	6 mm, 8 mm

Unit	Size
2	18 mm
3	18 mm

3. Long tape measure	11. Phillips screwdriver
4. Short tape measure	12. Slotted screwdriver
5. Drill bit – 1/8" (3 mm)	13. Needle-nose pliers
6. Power drill	14. Locking Pliers
7. Hacksaw	15. Center punch
8. Side cutters	16. Hammer
9. Rat-tail file	17. Electric tape (use to mark foil)
10. Straight edge	18. Vise (tape jaws to protect foil)



Tools Required

Measure A and add to this chart and length chart below		
	Inches	mm
A		
B	1.3*	33*
E	22.5	570
F	6.3	160
G		
Total A+B+E+F+G		

*Add 1.4" (35 mm) if using a halyard deflector.

Make sure upper measurement points of A and pin-to-pin are the same.

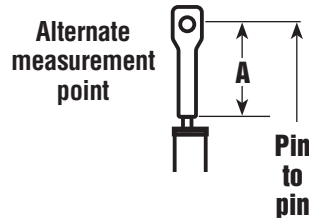

TOP FOIL LENGTH WORKSHEET

1	Pin-to-pin length	
2	Subtract ABEFG	-
3	Result (pin-to-pin - ABEFG)	
4	Subtract D	-
To find "D" pick number from chart below that is closest to, but not greater than total from step 3.		
	Inches	mm
	5 x 78.74 = 393.7	5 x 2000 = 10000
	6 x 78.74 = 472.4	6 x 2000 = 12000
	7 x 78.74 = 551.2	7 x 2000 = 14000
	8 x 78.74 = 629.9	8 x 2000 = 16000
	9 x 78.74 = 708.7	9 x 2000 = 18000
Example - If result from Step 3 is:		
500 inches "D" = 472.4 inches 12,500 mm "D" = 12,000 mm		
5	Result (C) top foil length	

UNIT 2

Tip: Check to see if the foil fits over the marine eye. If yes, assemble foils and lower unit following instructions. Measure and cut the top foil after other foils are assembled.

IMPORTANT! Identify top foil before cutting. Use end with foil screw holes for connector.

Length Check

After completing worksheet above fill in A, C, D and G below. Add "A" through "G" to confirm total equals your pin-to-pin measurement.

Length Chart			
Dimensions	Inches	mm	
A Center of pin to bottom of terminal			
B Bottom of terminal to top of foil	1.3*	33*	
C Top foil length	**	**	
D Number of foils _____ x 78.74" (2000 mm)			
E Adjuster tube at just over midpoint	22.5	570	
F Drum height	6.3	160	
G Top of leg kit to clevis pin			
Pin-to-Pin Length			

*Add 1.14" (35 mm) if using a halyard deflector.

**If top foil length is 9" to 6" (230 to 150 mm) cut the foil at 9" (230 mm). If the top foil is shorter than 6" (150 mm) do not use a cut top foil. A full length foil will be the top foil.

G Top of Leg Kit to Clevis Pin					
Toggle Part No.	Type	Clevis Pin		G Distance	
		in	mm	in	mm
7322.20 5/8	Short leg kit	5/8"	15.9 mm	4.9	125
7322.20 3/4	Short leg kit	3/4"	19.1 mm	4.9	125
7322.22 5/8	Medium leg kit	5/8"	15.9 mm	11.9	302
7322.22 3/4	Medium leg kit	3/4"	19.1 mm	12.2	310
7322.21 5/8	Long leg kit	5/8"	15.9 mm	16.7	425
7322.21 3/4	Long leg kit	3/4"	19.1 mm	16.7	425

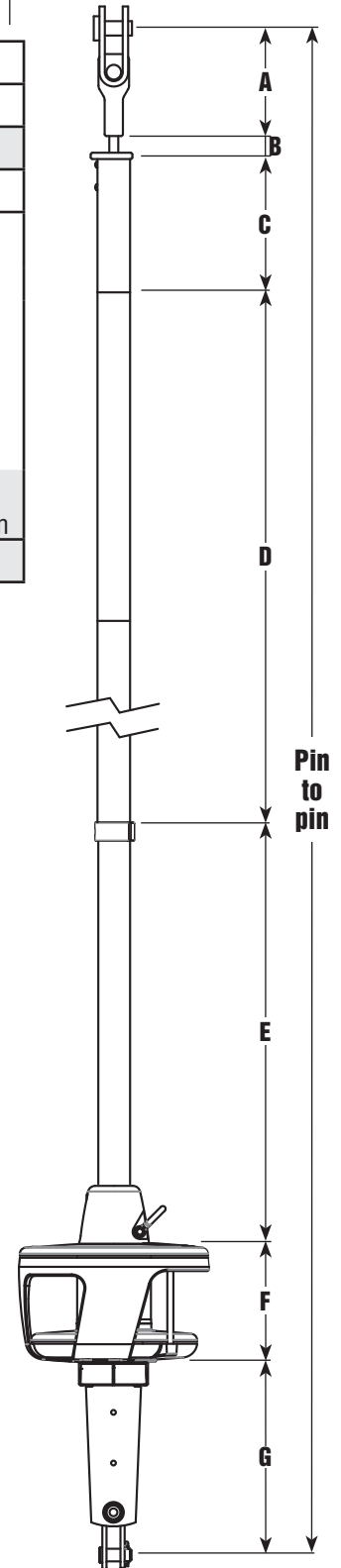

Measure A and add to this chart and length chart below		
	Inches	mm
A		
B	2.0*	51*
E	22.9	580
F	7.4	188
G		
Total A+B+E+F+G		

Make sure upper measurement points of A and pin-to-pin are the same.

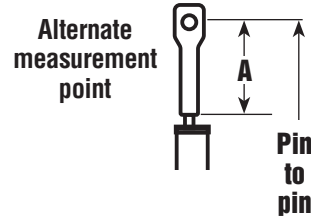

TOP FOIL LENGTH WORKSHEET

1	Pin-to-pin length	
2	Subtract ABEFG	-
3	Result (pin-to-pin - ABEFG)	
4	Subtract D	-
To find "D" pick number from chart below that is closest to, but not greater than total from step 3.		
	Inches	mm
	7 x 78.74 = 551.2	7 x 2000 = 14000
	8 x 78.74 = 629.9	8 x 2000 = 16000
	9 x 78.74 = 708.7	9 x 2000 = 18000
	10 x 78.74 = 787.4	10 x 2000 = 20000
	11 x 78.74 = 866.1	11 x 2000 = 22000
Example - If result from Step 3 is: 800 inches "D" = 787.4 inches 20,500 mm "D" = 20000 mm		
5	Result (C) top foil length	

*Add 1.5" (38 mm) if using a halyard deflector.

UNIT 3

Tip: Check to see if the foil fits over the marine eye. If yes, assemble foils and lower unit following instructions. Measure and cut the top foil after other foils are assembled.

IMPORTANT! Identify top foil before cutting. Use end with foil screw holes for connector.

Length Check

After completing worksheet above fill in A, C, D, and G below. Add "A" through "G" to confirm total equals your pin-to-pin measurement.

Length Chart		
Dimensions	Inches	mm
A Center of pin to bottom of terminal		
B Bottom of terminal to top of foil	2.0*	51*
C Top foil length		
D Number of foils _____ x 78.84" (2000 mm)		
E Adjuster tube at just over midpoint	22.9	580
F Drum height	7.4	188
G Top of leg kit to clevis pin		
Pin-to-pin length		

*Add 1.5" (38 mm) if using a halyard deflector.

**If top foil length is 11" to 7" (275 to 175 mm) cut the foil at 11" (275 mm). If the top foil is shorter than 7" (175 mm) do not use a cut top foil. A full length foil will be the top foil.

G Top of Leg Kit to Clevis Pin					
Toggle Part No.	Type	Clevis Pin		G Distance	
		in	mm	in	mm
7323.20 7/8	Short leg kit	7/8"	22.2 mm	6.5	165
7323.20 1	Short leg kit	1"	25.4 mm	6.5	165
7323.22 7/8	Medium leg kit	7/8"	22.2 mm	15.0	380
7323.22 1	Medium leg kit	1"	25.4 mm	15.4	391
7323.21 7/8	Long leg kit	7/8"	22.2 mm	21.1	535
7323.21 1	Long leg kit	1"	25.4 mm	21.1	535

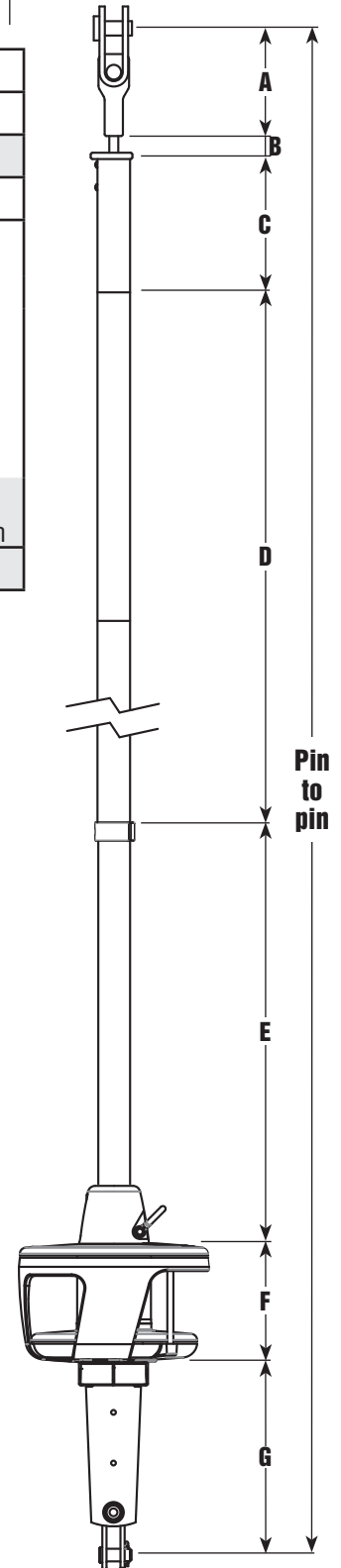

Rigger supplied: Eye at lower end of stay or turnbuckle to mate with toggle. Use dimensions of Harken toggle below to build stay to correct length.

Tip: Turnbuckles should be one-half to two-thirds open to allow shortening for new wire stretch and for fine-tuning mast rake.

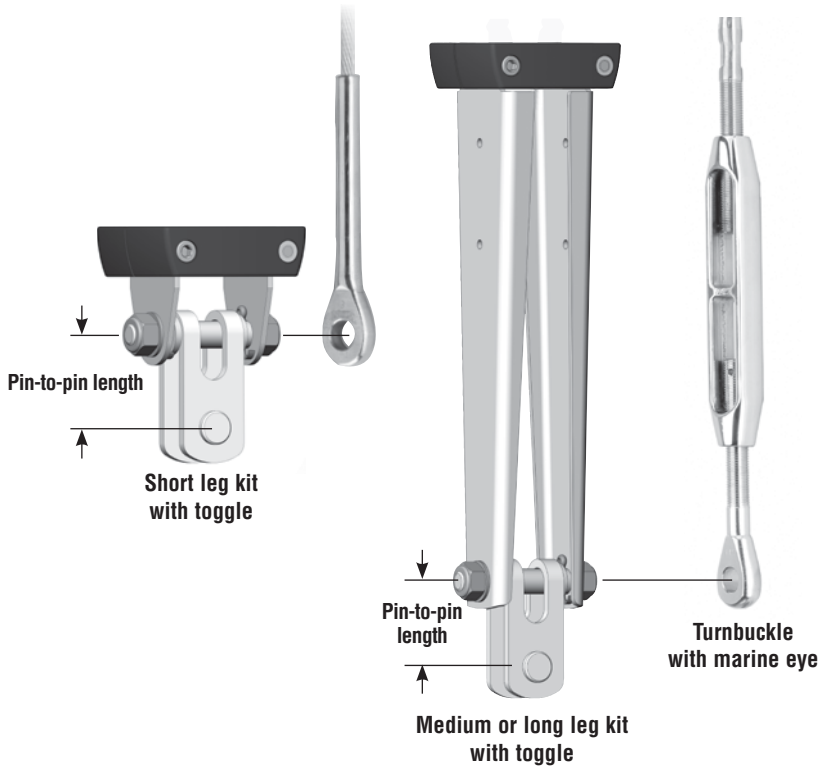

Unit	Type	Leg Kit Toggle Assembly Part No.	Clevis Pin Ø		Pin-to-Pin (P-P) Length	
			in	mm	in	mm
2	Short	7322.20 5/8				
	Medium	7322.22 5/8	5/8	16	2 ¹ / ₁₆	52
	Long	7322.21 5/8				
3	Short	7322.20 3/4				
	Medium	7322.22 3/4	3/4	19	2 ³ / ₈	60
	Long	7322.21 3/4				
3	Short	7323.20 7/8				
	Medium	7323.22 7/8	7/8	22	3	76
	Long	7323.21 7/8				
3	Short	7323.20 1				
	Medium	7323.22 1	1	25	3 ⁷ / ₁₆	87
	Long	7323.21 1				

Options for Snaking Stay into Foils

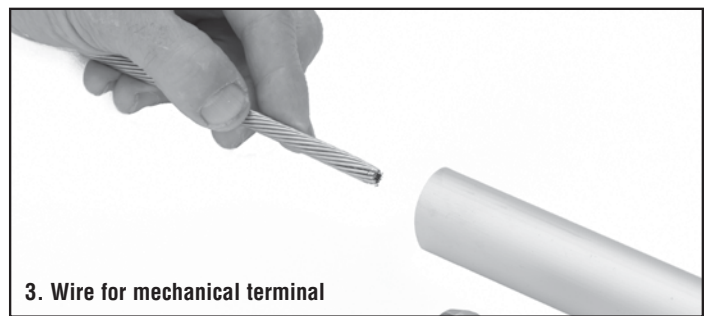
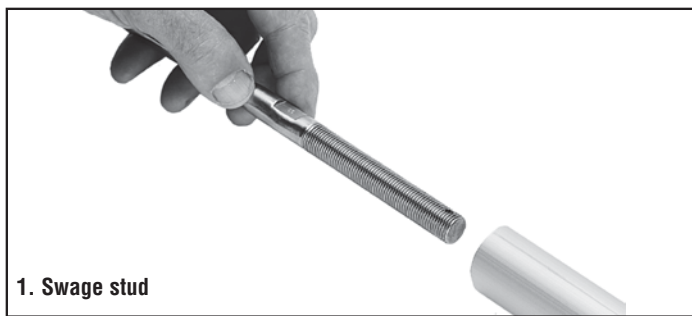

WARNING! Using a threaded nosepiece with only adhesive at the upper rod eye terminal may result in headstay system failure. Use a Harken rod adapter stud. See www.harken.com/manuals for additional safety information.

Confirm foil length by laying foils alongside stay with turnbuckle components. Pull stay straight. Attach Harken toggle to bottom of stay. Adjust turnbuckle, if used, so that length of stay with Harken toggle will fit boat. Ideally, turnbuckle will be one-half to two-thirds open to allow for rig adjustment. Temporarily clamp short or long leg kit to bottom of unit. Line up:

- A. Bottom of full length foil with holes in adjuster tube. Set adjuster tube just above the mid-point of adjustment range.
- B. Holes at lower end of adjust tube with drum assembly holes.
- C. Lower holes in leg kit line up with eye in toggle.

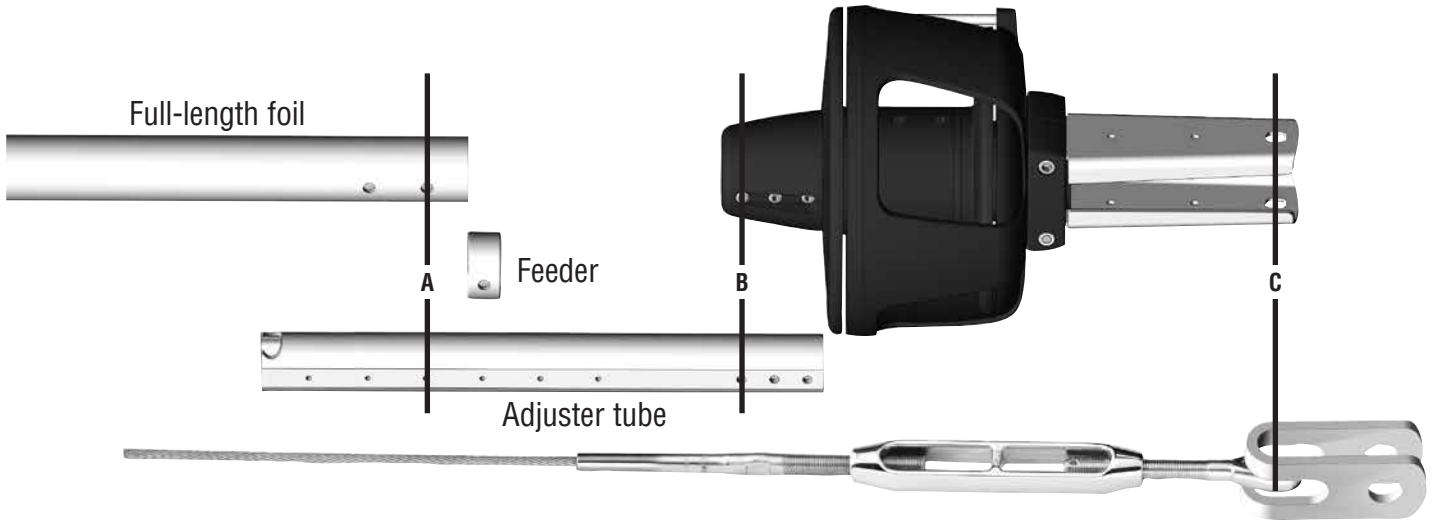

Actual adjuster tube will have 12 to 14 adjuster holes. Line up the foil so it is just above the midpoint of adjustment.

Lay all foils out alongside stay and confirm that there will be enough space between the bottom of the marine eye and the end of the top foil. If necessary, go to lower end, reposition the adjuster tube and lower full length foil to another position. Confirm that there are two holes for the foil and one for the feeder.

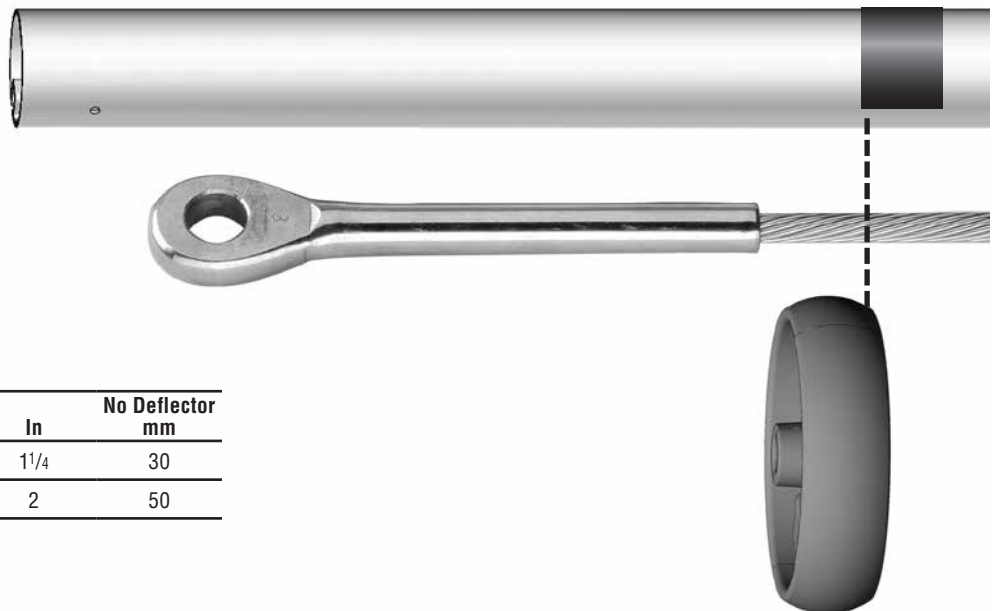

Unit	Deflector		No Deflector	
	in	mm	In	mm
2	2 1/2	65	1 1/4	30
3	3 1/2	90	2	50

Tip: Check to see if the foil fits over the marine eye. If yes, assemble all foils and lower unit following instructions. Measure and cut the top foil when all other foils are assembled.

Determine top foil length using charts or by laying foils alongside wire. **IMPORTANT! Confirm that you are using the correct unit size worksheet.** Be sure to lay foils, lower unit, and leg kit alongside stay to confirm length before cutting.

Use tape to mark foil. Cut foil to length.

Tool: hacksaw

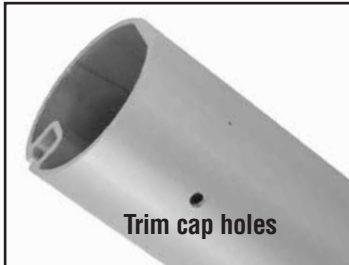

Cut off this end with trim cap hole. Hole is only used with full length 78³/₄" (2000 mm) foil as top foil.

Deburr inside edge using a file.

Tool: rat-tail file

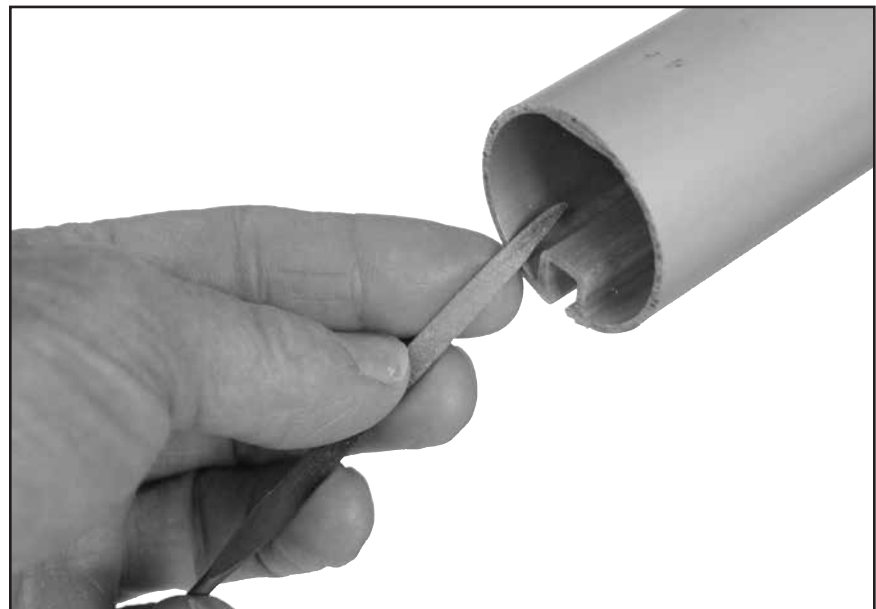

Label top foil and identify which end will be at the top when installed. You will be drilling each side near the top.

Lay top foil alongside cutoff piece. Use locking pliers to clamp foils together at the interior flat surfaces opposite the sail grooves.

Use a flat metal object (i.e. metal ruler) to scribe lines on one side of foil. Leave foils clamped for drilling.

Tools: straight edge, locking pliers



Assembly

Cutting/Drilling Top Foil

Measure from the end of the foil and put a mark showing hole distance from top of foil.

Unit	Decimal in	Fraction in	mm
2	1.38"	1 ³ / ₈ "	35
3	1.77"	1 ³ / ₄ "	45

Tool: short tape measure



Use center punch to start hole. Drill one of two holes for trim cap.

Drill size: 1/8" (3.2 mm)

Keeping foils clamped together, flip them to the other side and repeat the procedure so there is a hole on each side.

Tools: electric drill, drill bit, center punch



1. Identify special length top foil with trim cap holes.

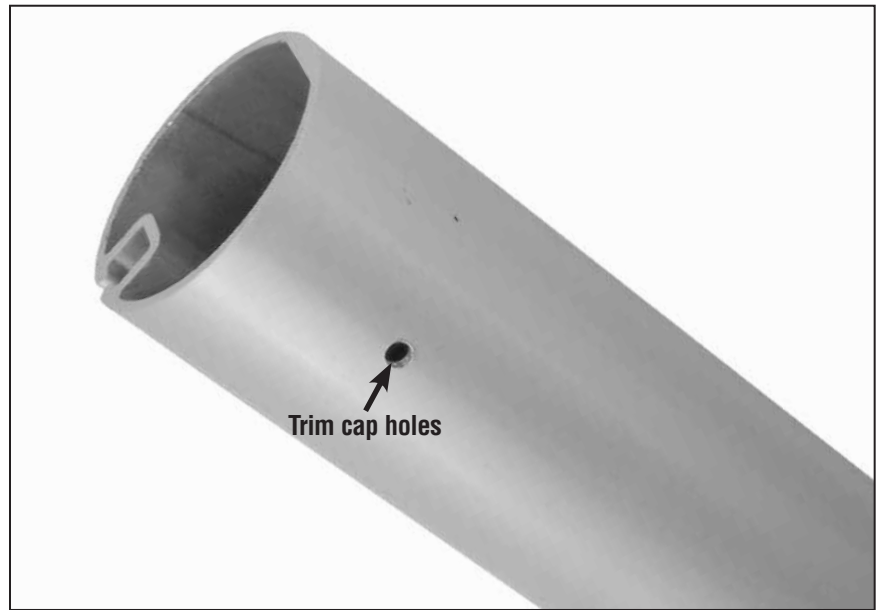

2. Slide top foil and 2 m foils and connectors onto wire.

2a. Load connector so bushing cutouts facing up towards the top of stay.

Note: On top foils under 12" (300 mm), load top connector so that cutouts for bushings face down toward the bottom of stay.

2b. Load onto wire from top and/or bottom.

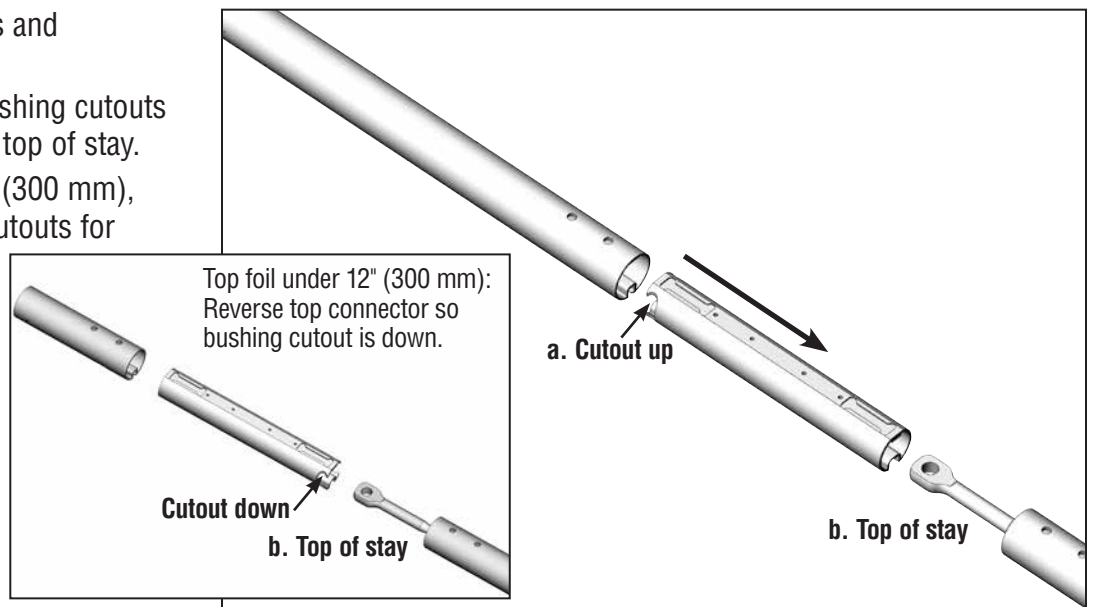

3. Make sure that special length top foil with trim cap holes is at top of stay.

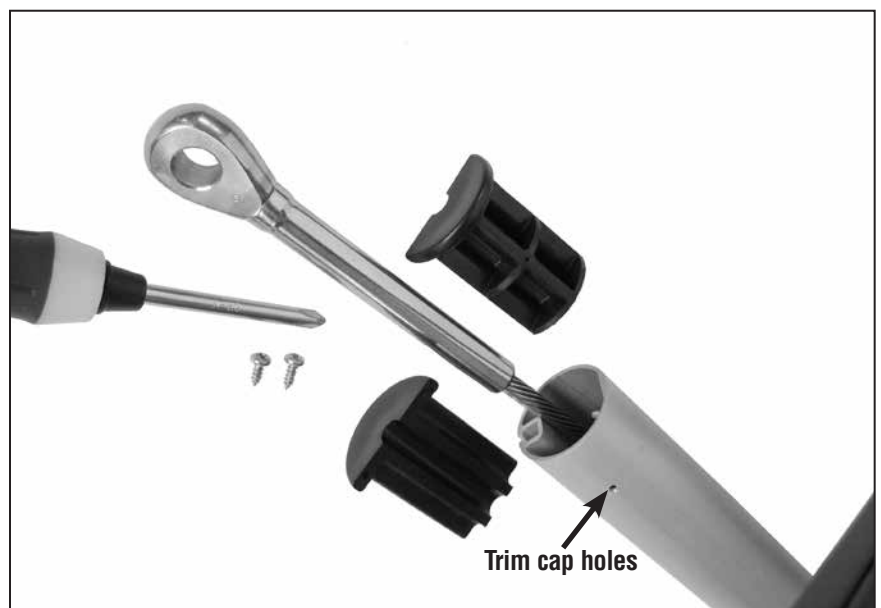

4. Put trim cap halves together over wire and tap in place.

Tool: hammer



5. Secure with trim cap screws.

Tool: Phillips screwdriver



6. If using halyard deflector, install above foil. Use red Loctite® on screws.

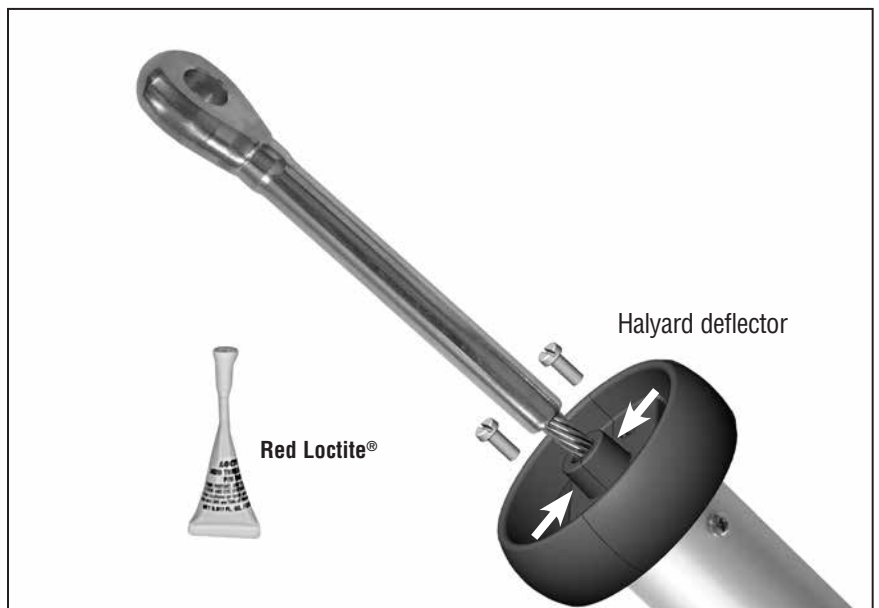

7. Hold plastic bushing halves in cutouts and over wire and insert up into foil.

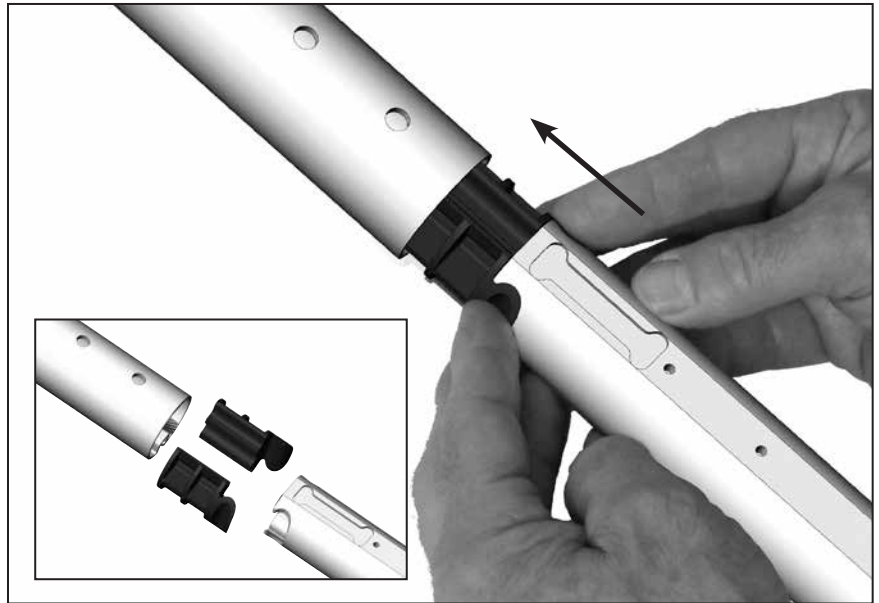

7a. Make sure foil and connector screw holes are facing up.

7b. Make sure connector and foil are aligned.

7c. Hold plastic wedge in place with thumb as you insert into foil. Align foil holes with connector screw holes.

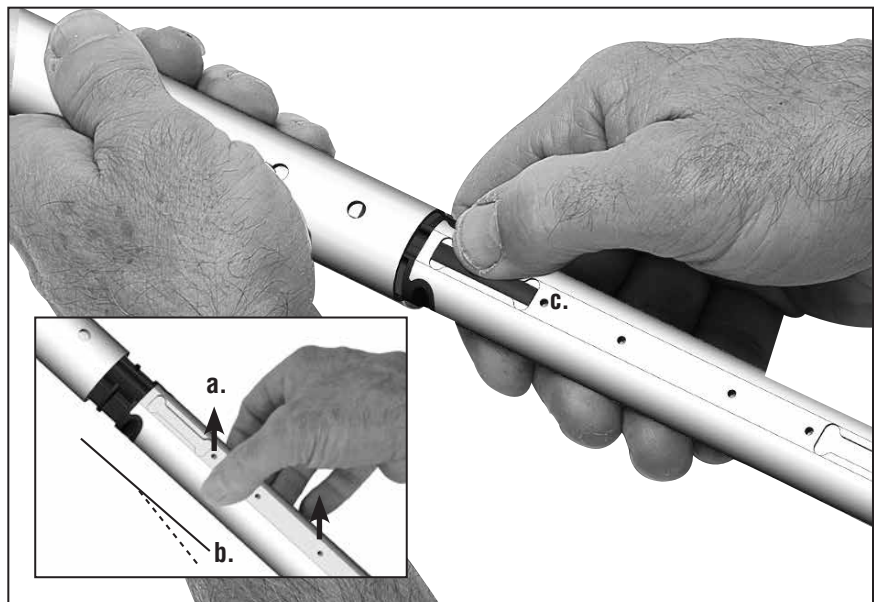

8. Put red Loctite® in foil screw holes and secure with foil screws.

Tool: slotted screwdriver

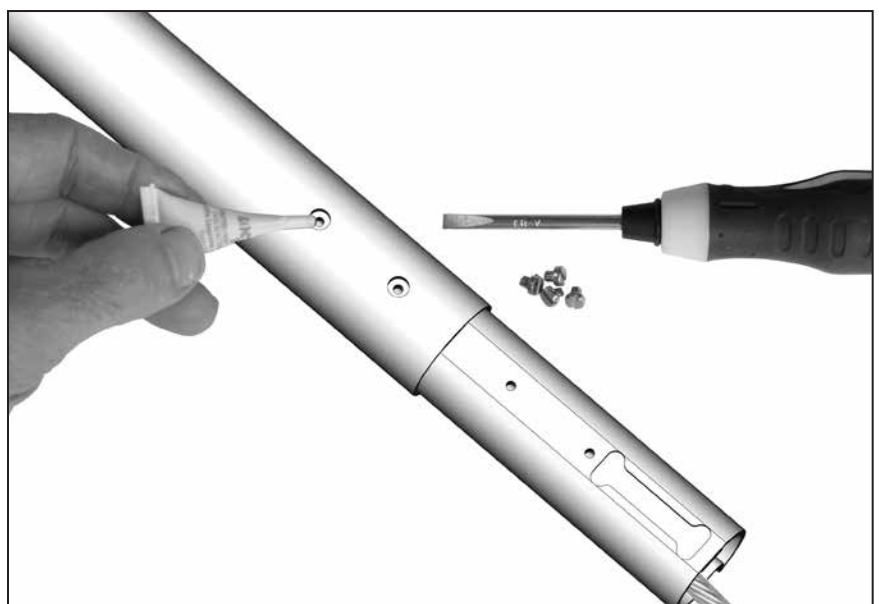

9. Join lower part of connector to next foil.
Put red Loctite® on screw holes. Secure with foil screws.

Loctite is a trademark of Henkel AG & Company KGaA



10. Install connector bushings in top of adjuster tube and insert into 2 m foil.

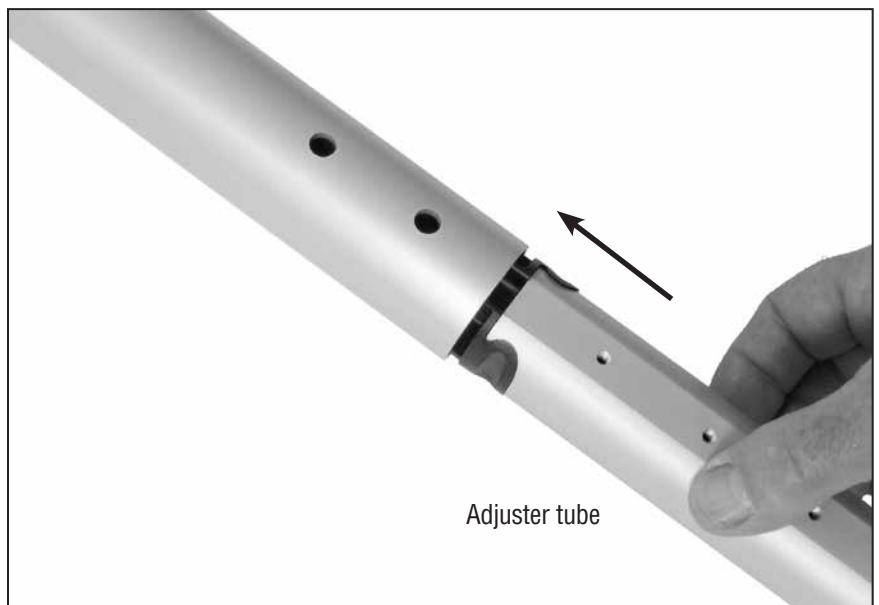

- 10a. Make sure foil and adjuster tube screw holes are facing up.
10b. Make sure adjuster tube and foil are aligned.
10c. Do not fasten with foil screws at this time.

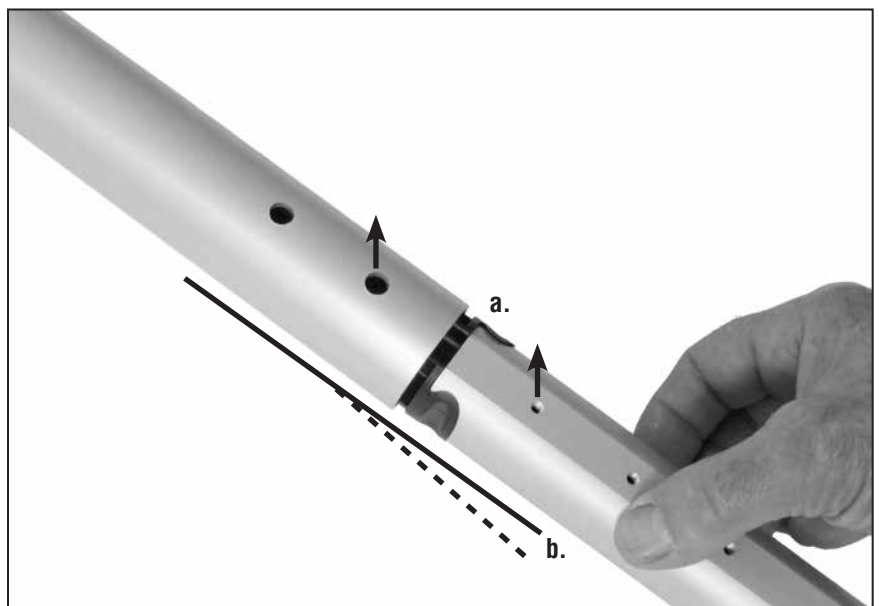

11. Place adjuster tube bushings over wire and insert into foils until tab snaps into holes on either side of adjuster tube. Tap in place.

Tool: hammer

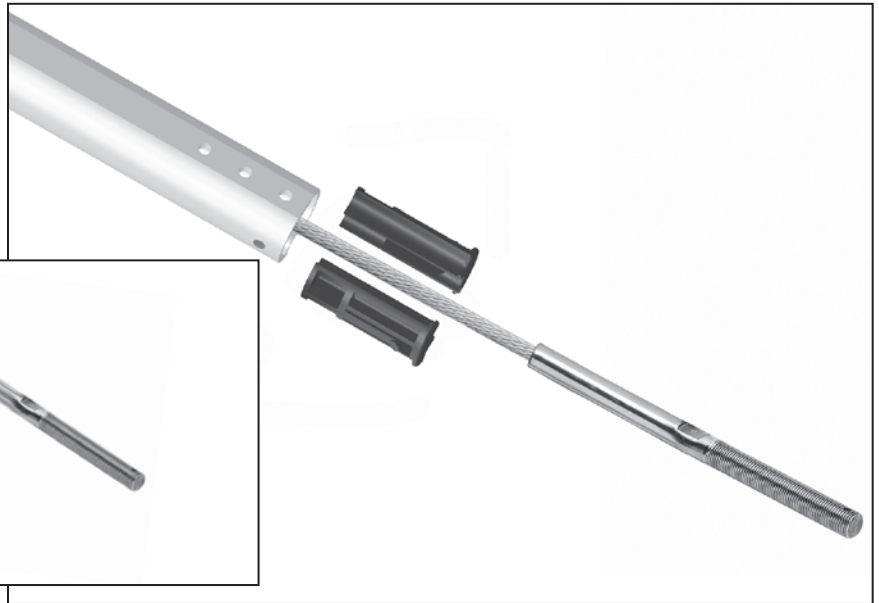

12. Slide halyard swivel onto foil so longer part is toward top of stay.

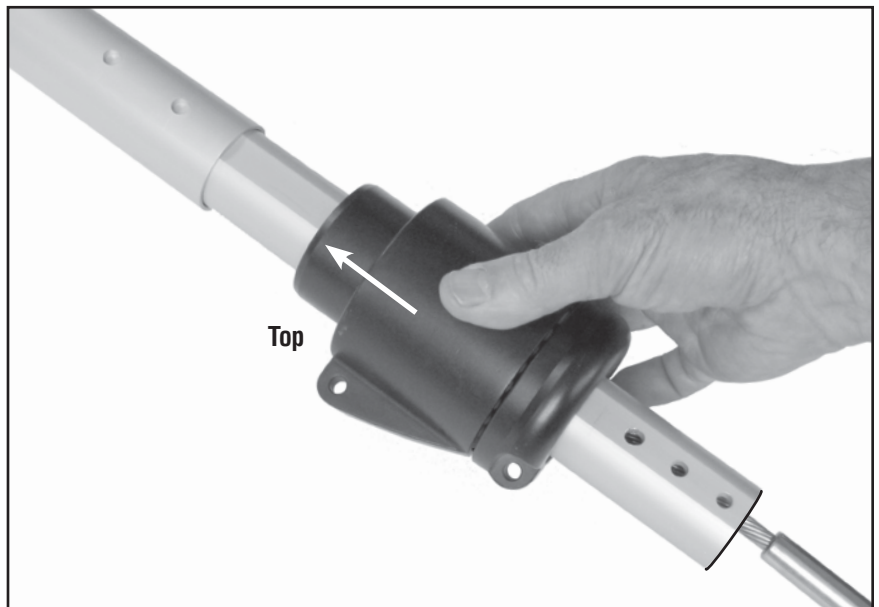

13. Slide feeder onto adjuster tube. **Do not secure with screw until later.**

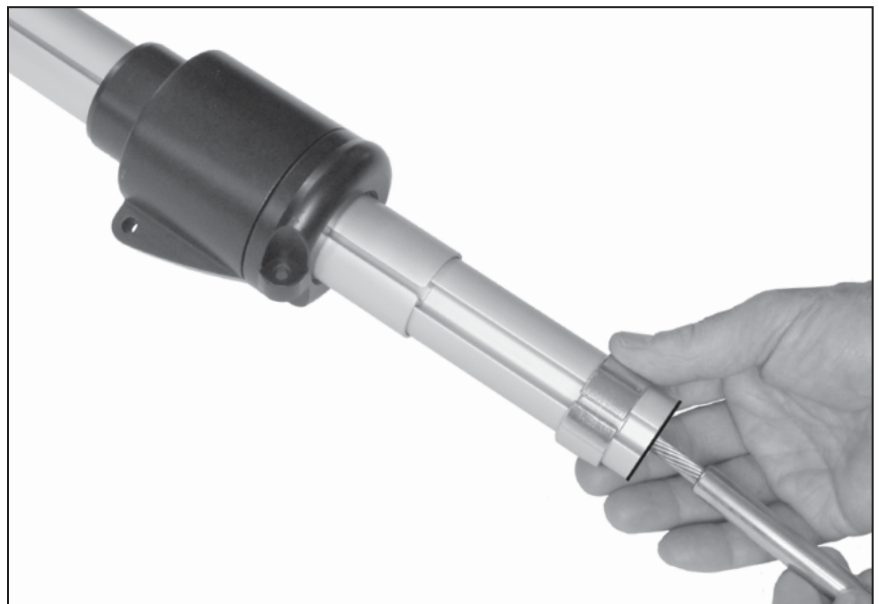

14. Slide drum assembly onto adjuster tube.



15. Put blue Loctite® on screw holes.
Secure with adjuster tube clamp screws.



16. Capture jaw/jaw toggle on eye using
threaded crosspin.

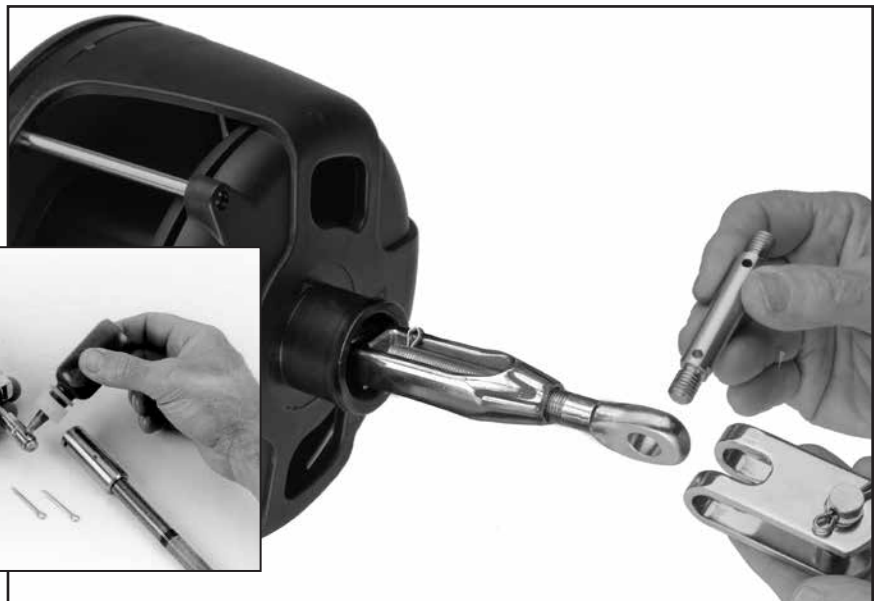

When using Harken rod
adapter stud, be sure to use
red Loctite® and cotter pins
to lock nosepiece into stud.



17. Slide one spacer on either side of jaw/jaw toggle.

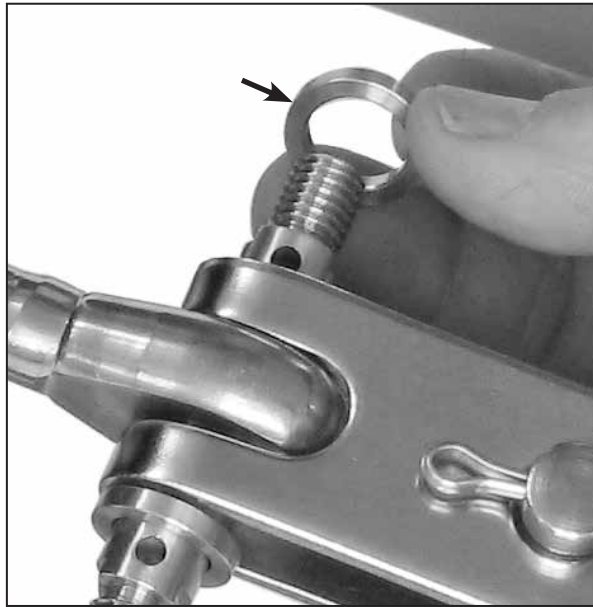

18. Secure using cotter pins.

Tools: slotted screwdriver, side cutters



19. Slip leg and washers onto threaded crosspin.

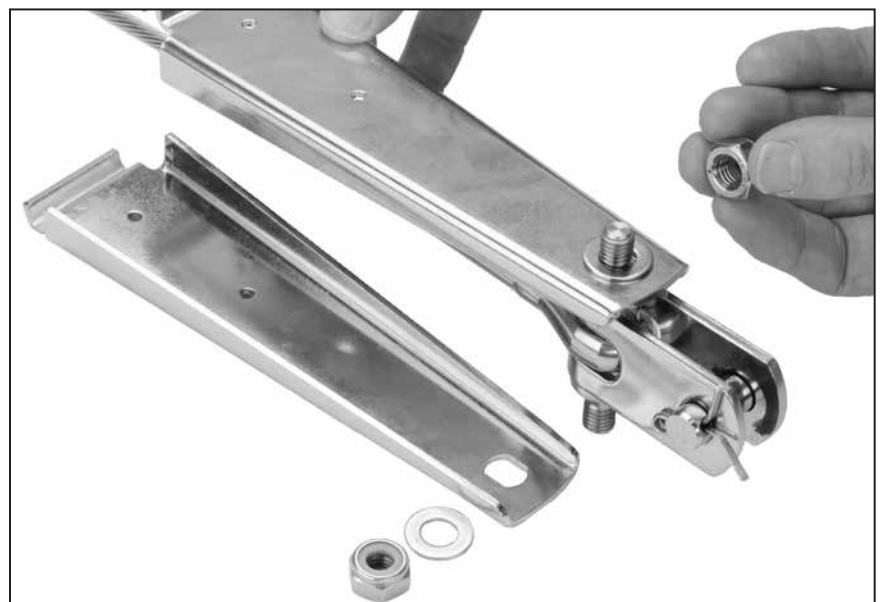

19a. Make sure **flat holes** in **leg** line up with **threaded crosspin flats**.

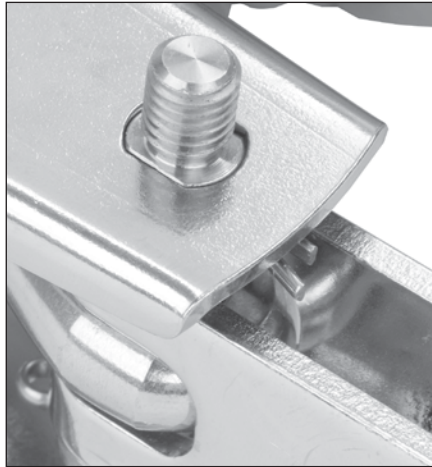
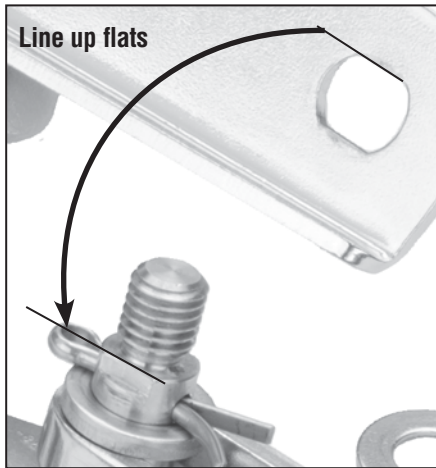

19b. Secure using washers and lock nuts.

Tools: socket or open end wrench

Unit	Size
2	16 mm
3	18 mm

If stay length is set, use side cutters or needle-nose pliers to bend cotter pin to secure turnbuckle.

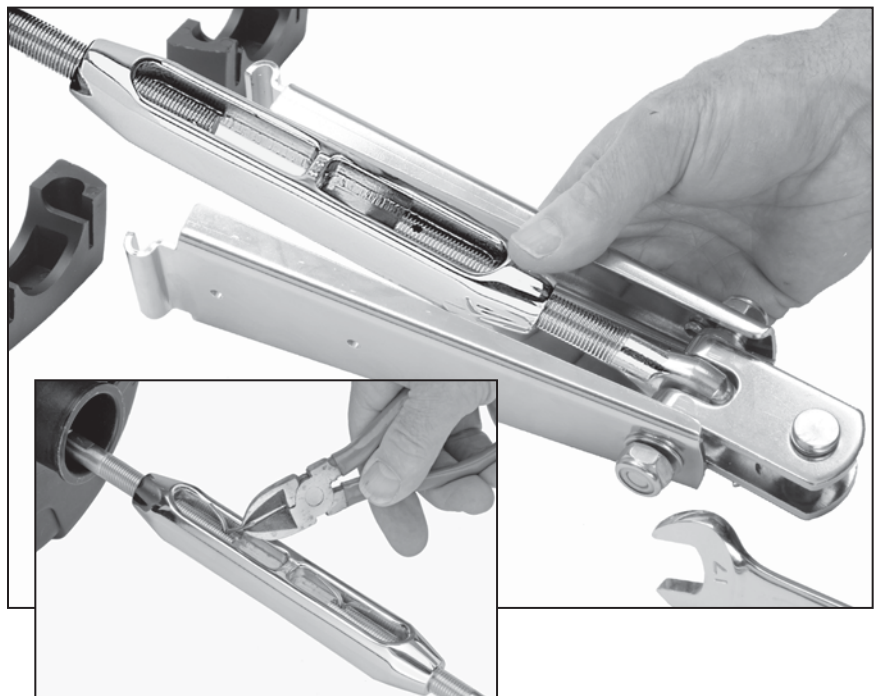

20. Capture legs in one of the two collars.

Tip: If the legs do not fit collar, loosen lock nuts at threaded crosspin.

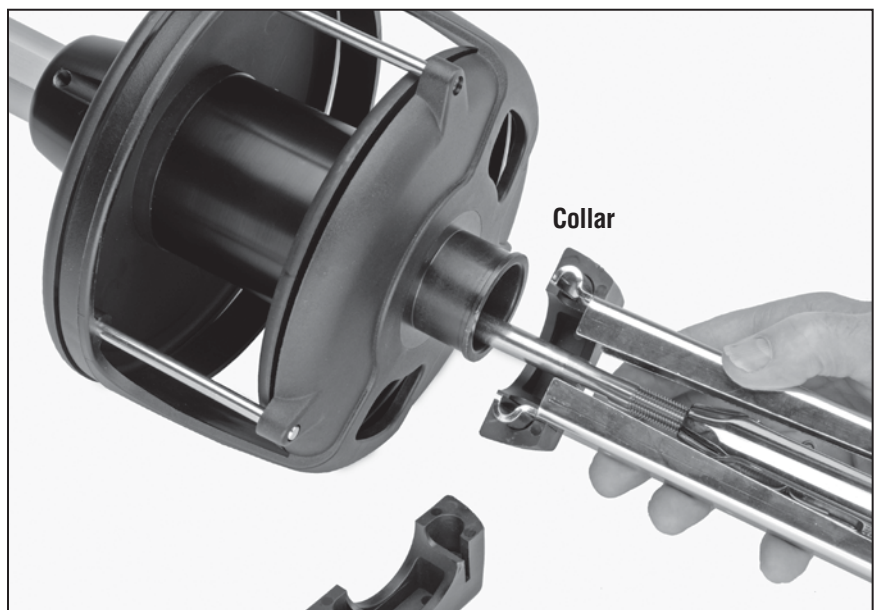

21. Slip leg kit assembly onto neck of drum assembly and fit other collar.



22. Secure using collar screws.

Tools: hex key	
Unit	Size
2	6 mm
3	8 mm



23. Push the assembled foils up toward the top of the stay leaving 1" to 2" (25 to 50 mm) of space between the top of the deflector or the trim cap and bottom of marine eye. Align all three holes at bottom of adjuster tube. Check to make sure there is space above halyard deflector or trim cap.

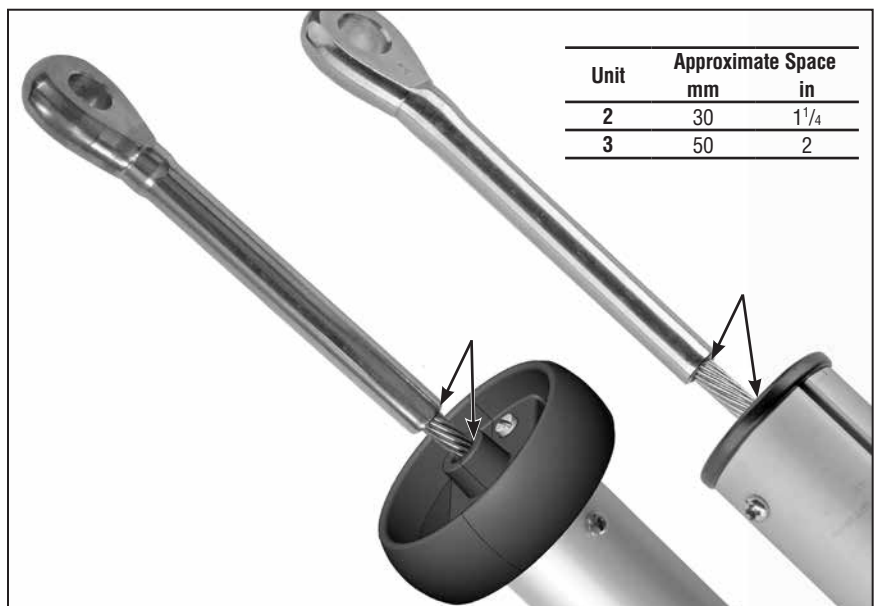

24. Locate nearest group of three screw holes in adjuster tube, two for the foil and one for the feeder. Put blue Loctite® in screw holes. Secure adjuster tube with foil screws.

Tool: slotted screwdriver

Loctite is a trademark of Henkel AG & Company KGaA

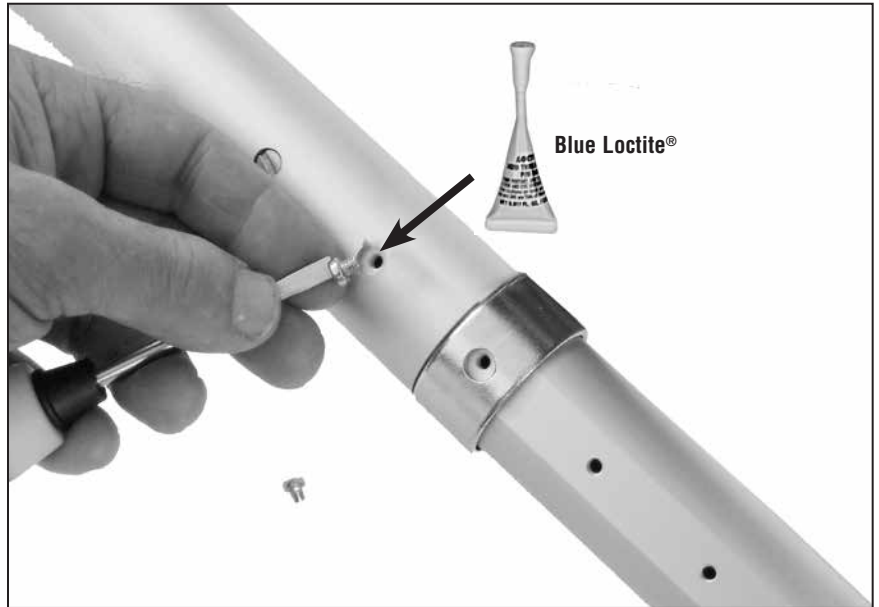

25. Slide feeder to third hole and secure using foil screw and blue Loctite®.

Tool: slotted screwdriver



26. Once on boat, loosen collar screws enough to rotate opening in drum assembly towards lead blocks. Put blue Loctite® on screws and tighten.

Tools: hex driver

Unit	Size
2	6 mm
3	8 mm



Mount Lead Blocks

Note: Harken lead blocks referenced below are an available option. Boat manufacturers may have alternate methods of running furling line to cockpit.

Furling line can be led down either side of boat. If boat is in slip, consider mounting opposite dock.

Remove four screws on stanchion blocks. Clamp blocks to stanchions. See instructions below.

Tip: Start all four screws before tightening.

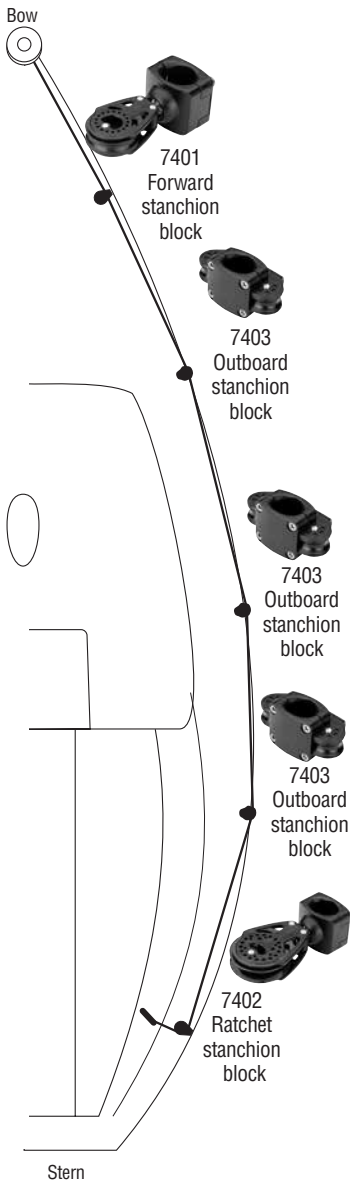

7401 Forward Stanchion Block

Position 7401 forward stanchion block so line enters drum at right angles to headstay and centers vertically in opening. Install so line is inside stanchion.

Correct block position is critical to even line spooling and ease of furling.

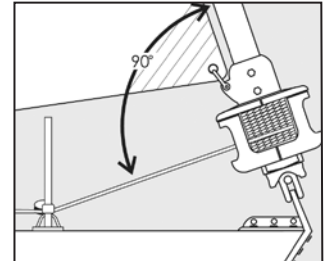

7403 Outboard Stanchion Blocks

Install 7403 outboard stanchion blocks so line is outside stanchions.

Number and placement of leads depends on boat length and number/configuration of stanchions.



7402 Ratchet Stanchion Block

Mount 7402 ratchet stanchion block as farthest-aft lead to prevent line overrides in drum when unfurling. Position ratchet block so line turns at least 90°.

Install so line is inside stanchion.

Lead line through block so ratchet makes a clicking sound when pulling line to furl sail.

Tip: Make sure ratchet switch is in "ON" position. If there is no clicking sound, lead line through block in opposite direction.

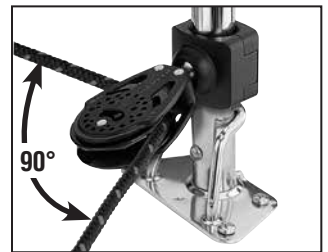

Lead line to furling line cleat in cockpit.

HCP168 Furling Line Cleat

Install so line is angled as shown. Use #10 (5 mm) fasteners.

Note: As furling line lead changes, make sure line doesn't chafe against line guard. Rotate drum assembly if necessary, see page 22.

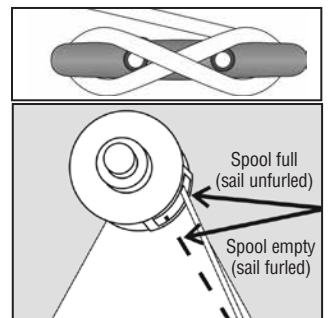

Add Line to Drum Assembly

Run line into drum assembly between guard posts and out hole in lower plate of spool. Exit opening in drum assembly as shown below. Tie a small overhand knot and pull it up tightly against spool.

IMPORTANT! Do not run line through plastic opening in drum assembly.

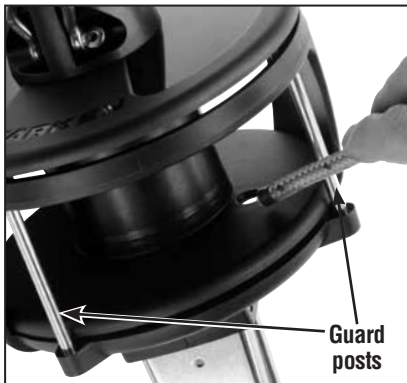

Guard posts



Do not run line through this opening.



Line through hole and opening.



Tie a small overhand knot and pull it up tightly against spool. Spool must turn freely to furl and unfurl sail easily.

Wrap Line on Spool

Note location of sun cover on sail. Rotate spool to wrap line.

Sun Cover On	Turn Spool
Starboard	Clockwise
Port	Counterclockwise

Turn spool until there is a tail of line in the cockpit measuring about 1.5 m (5') beyond the cleat or rope clutch.



Sun cover on starboard side: wrap line by turning clockwise



Sun cover on port side: wrap line by turning counterclockwise

Storm Sails

Storm sails or heavy air working jibs are necessary when sailing offshore where it is not possible to easily reach safe harbor.

These sails will generally require pendants to ensure that halyard swivel is properly positioned at top of headstay. See page 26.

Remember that heavy air working jibs and storm jibs may be reefed and furled like any other sail.



WARNING! Sail can become uncontrollable when raising in windy conditions, resulting in loss of footing. Choose wind conditions to match your experience and ability. If changing sails underway, take all safety precautions when working on the foredeck. See www.harken.com/manuals General Warnings and Instructions.

Raise Sail

Choose conditions with little or no wind when raising sail at the dock. Have bow of boat pointing into the wind.

- 1) **Note:** Make sure drum assembly is wrapped with line. Shackle tack of sail to drum. Install shackle so screw pin head is on same side as sun cover.
- 2) Secure genoa sheets to clew of sail using bowline knot. See www.harken.com/knots or consult a knot-tying book.
IMPORTANT! If you are not comfortable tying this or other secure knots, get help from professional rigger.
- 3) Attach genoa halyard to halyard swivel.
- 4) Carefully guide sail into feeder and then into foil groove.
- 5) Attach head or pendant at head of sail to halyard swivel.
- 6) Hoist sail slowly, making sure luff tape does not jam in foil.
Important! Forcing sail can cause luff tape to rip.

Tip: New sails are often stiff and may hang up at feeder during raising. Do not force sail when it hangs up—lower and remove twist. Sails "break in" with use and will become easier to raise.

- 7) Line up front of sail so it is parallel to foil and feeds smoothly when sail is hoisted.
- 8) Put moderate tension on the halyard and secure.
- 9) Check the top area of the furler for interference from halyards.
See "Check halyards."
- 10) Practice rolling sail in and out at the dock. See "Furl" and "Unroll sail."
- 11) If not sailing right away, make sure sail is furled carefully.
See "Secure sail."

IMPORTANT! Pay careful attention to "Secure sail." If leaving the boat, you must secure sail to prevent damage if wind increases while you are away.

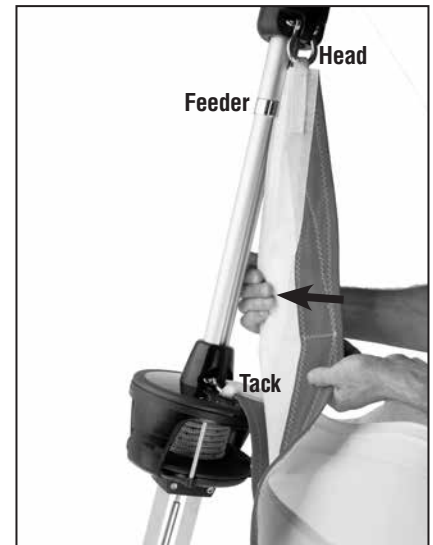

Check Halyards

Once sail is raised, stand back from boat and use binoculars to make sure there is no interference from halyards.

The jib halyard must exert a slight pull to the rear. This allows the foil to turn while halyard remains stationary.

1. Halyard swivel must be 40 mm (1½")–150 mm (6") from top of foil.
2. Halyard must pull slightly to rear (8°–10°).

Halyard Deflector

If the stay attachment is close to the halyard exit the halyard will not pull to the rear 8° or more and can catch on the top of the foil. Use halyard deflector to move the halyard away. Check to make sure there is enough space between the trim cap and the bottom of the terminal. Halyard deflector thickness:

Unit	Part	Thickness
2	7303	35 mm (1⅜")
3	7304	38 mm (1½")

Short Luff Length Sail

If sail luff is too short to position the halyard swivel 40 mm–100 mm from top of foil assembly, you must add a pendant to the head of sail.

Determine Pendant Length

1. Raise sail, but do not attach tack to drum assembly.
2. Position halyard swivel 40–150 mm from top of foil.
3. Secure halyard.
4. Tie a piece of rope between sail tack and tack shackle.
6. Tension sail.
7. Measure distance from tack shackle to sail tack.

Have a rigger make a pendant to this length using plastic-coated wire. It should be **permanently attached to head of sail**.

The most serious problem with furling systems occurs when the jib halyard wraps around the headstay foil. A halyard wrap will keep you from furling/unfurling and may cause serious damage to the unit and halyard.

IMPORTANT! A furler with a low halyard swivel may furl correctly in smooth water/calm conditions, but the halyard will be likely to wrap in a rough sea.



WARNING! In severe cases, a halyard wrap can cause loss of control of boat and/or headstay can break suddenly. Make sure halyard is clear of top foil before using system.

If halyard wraps, do not force unit to turn. Attempt to open sail by carefully furling in and out a little at a time. If sail will unfurl, lower it by releasing jib halyard. If sail will not furl, try to remove one sheet and run the tied sheet around foil. Use sheet to pull sail around foil and repeat. This should only be attempted by expert users observing all safety requirements for going forward.

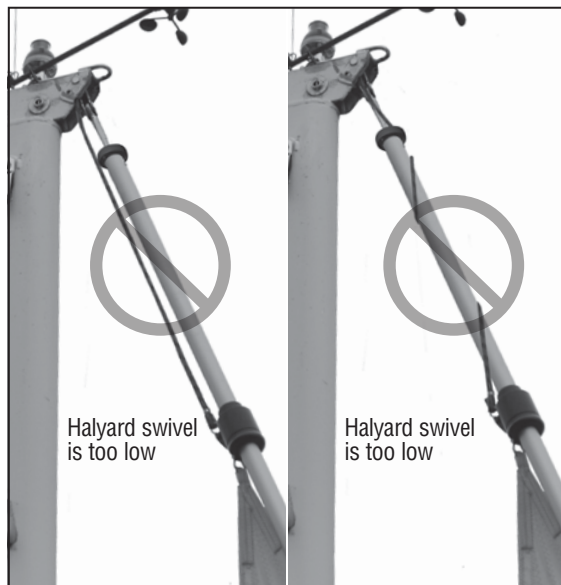
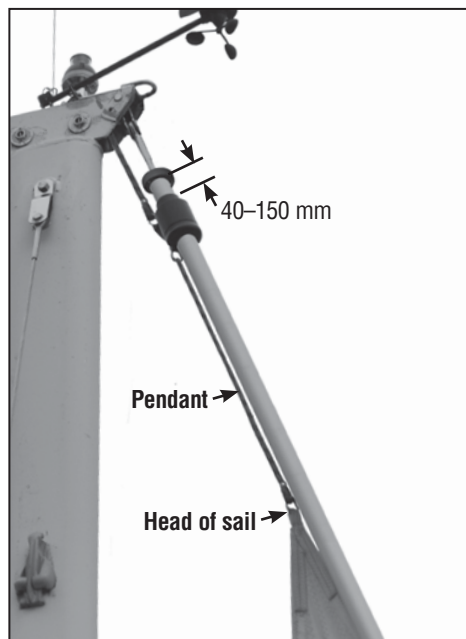
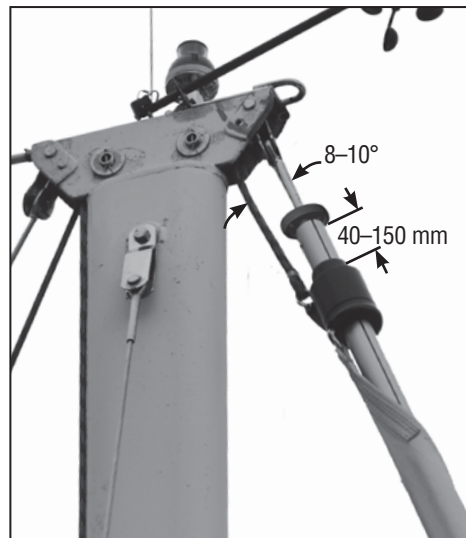

Halyard Tension

The jib halyard should be firm, but not too tight.

Tip: *The foil supports sail along its length so halyard tension is used only to shape sails, not to support them. Use enough halyard tension to remove some wrinkles along luff of sail. Do not tension halyard enough to cause vertical wrinkles in luff of sail. Tension to adjust position of draft in sail to suit sailing conditions. Halyard should be firm but not tight. If in doubt ease halyard tension. To protect sail, ease halyard when boat is not in use.*

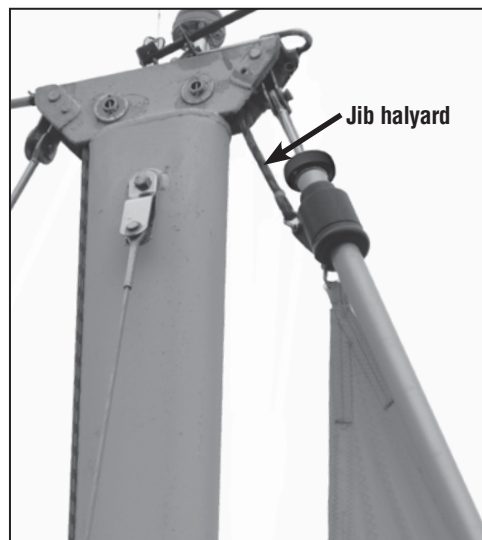

Backstay Adjusters and Halyard Tension

Backstay adjusters allow headstay tension to be varied to change sail shape to match conditions. They permit a very tight headstay to be eased when boat is not in use. For best performance, consider adding a backstay adjuster: either a block and tackle, a mechanical adjuster, or hydraulic adjuster like those offered by Harken.

Remember to keep headstay tight for best performance when furling or reefing.

IMPORTANT! **Ease halyard before tensioning backstay adjuster.** If not, backstay adjuster will increase halyard tension and could damage the sail or furling system.

Racing boats often slack the headstay completely when sailing downwind. Check to be sure that foil does not jam against upper headstay terminal when backstay is released. It may be necessary to shorten foil slightly to prevent this.



Spinnaker Halyards

Make sure spinnaker halyards are clear of furler.



WARNING! In severe cases, spinnaker halyards can jam furler causing loss of control of boat. Make sure all halyards are clear of top of top foil.

On many boats it will not be possible to attach the spinnaker halyard to the bow pulpit or it may be "sucked" into jib when furling.

On some boats the spinnaker halyard lays across the headstay and will catch on halyard swivel, foils, or jib halyard.

Boats with external halyards may find it necessary to flip both ends of spinnaker halyard behind spreaders to prevent fouling with furling system.

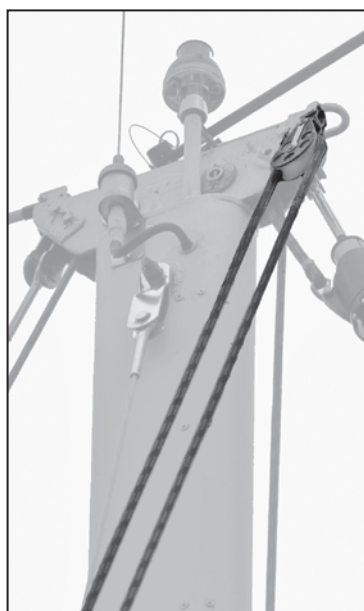

Unroll Sail

Uncleat furling line. Pull sheets to unfurl sail.

IMPORTANT! Keep tension on furling line when unrolling sail so line spools tightly on drum. Use a Harken ratchet block or keep tension on the line by putting a single wrap of the furling line around a spare winch to provide drag on the line. This is very important when wind is blowing over 10 knots. When line is tightly spooled on drum it furls in much easier.



Furl

To furl or reef, ease the jib sheets and pull furling line.

In very light breeze, place some tension on jib sheet to insure a tight furl.

In a stronger breeze, you must **completely** luff sail by **totally** slacking jib sheets before furling.

The furling line should pull readily. The amount of force required is related to amount of wind, but a unit should never require use of a winch to furl. If the sail will not furl, or if furling requires a great deal of effort, there is a problem with system. Consult "Troubleshoot" on page 32. Do not use a winch to force a system to turn. If you are certain that system is operating properly you may use a winch to make furling easier.

Reef

A sail may be partially furled before you resume sailing. This is known as reefing.

Tip: Place marks on foot of sail for a variety of reefed jib sizes. Place marks on jib lead track so lead block position matches reefed jib.

Reef sails to balance boat and reduce heel.

Tip: Reef sails to improve visibility or to slow boat while sailing in congested areas, or while entering or leaving harbors.



Secure Sail

When furling the sail completely, make sure sheets and furling line are secured. Check amount of line on the spool compared to the furled sail before using the system.

A furled sail must have:

- a. Two to three wraps of jib sheet wrapped around sail.
- b. Two wraps minimum of line wound on spool.
- c. Furling line securely cleated.
- d. Jibsheets securely wrapped on winch and held in self-tailing jaws.

Furl at dock with tension on sheets to duplicate furling in high wind.

Remember sails furled in light wind and left loosely secured can be a problem if wind increases.

IMPORTANT! Remove sail from furler if extreme winds are predicted, especially if boat is left unattended.

IMPORTANT! Check all points above—a, b, c, and d—when leaving boat to avoid damage to furler or boat. A loosely rolled sail can catch wind in a storm. Sheets or furling lines can loosen as winds increase and allow furler to unroll.

Be sure mooring lines are not placed across furling line where they may cause chafe.

IMPORTANT! If no wraps of line are on spool, the line deadend can break the spool when the boat motors through waves.

If you want to:

Add more wraps of jibsheet on furled sail.	Untie jib sheets and keep sail completely rolled. Secure with sail tie.	Turn spool to unroll a couple of wraps of line.	Retie sheets.
Add more wraps of line on spool.		Turn spool to add a couple of wraps of line.	



Adjust Turnbuckle

Tools: See page 6 for sizes
Wrench for lock nuts
Hex key
Slotted screwdriver for foil screws
Sidecutters for cotter pins

Tip: Tape a flat cardboard box or a towel under the furler to catch any dropped parts.

Attach halyard to tack shackle, take out slack and secure.

Remove feeder screw and one foil screw.

While holding foils up, carefully remove screw and lower foils to drum assembly.

Tip: Have a helper lift foils and hold or use another halyard while removing last screw. To use a halyard to hold foils lifted, tie a rolling hitch to the foils using another line or use the actual halyard if suitable. See www.harken.com/knots for tying resources.



CAUTION! Foils have considerable weight and can drop and cut hands if placed underneath. Make sure foils are securely held up while adjusting turnbuckle.

Carefully remove plastic collar and screws.

Do not drop.

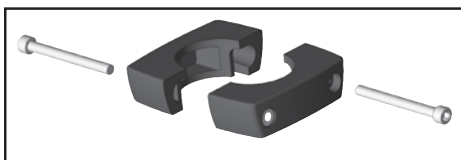

Loosen screws and separate legs from flats on crosspin. Rotate legs so they are laying on the deck.

IMPORTANT! Parts are easily lost.

Unlock turnbuckle and adjust.

Lock turnbuckle and reassemble leg kit parts.

Carefully loosen nut enough to move legs outwards and rotate out of the way. When reassembling, you must secure flats on both parts. See assembly step 19a, (page 20).

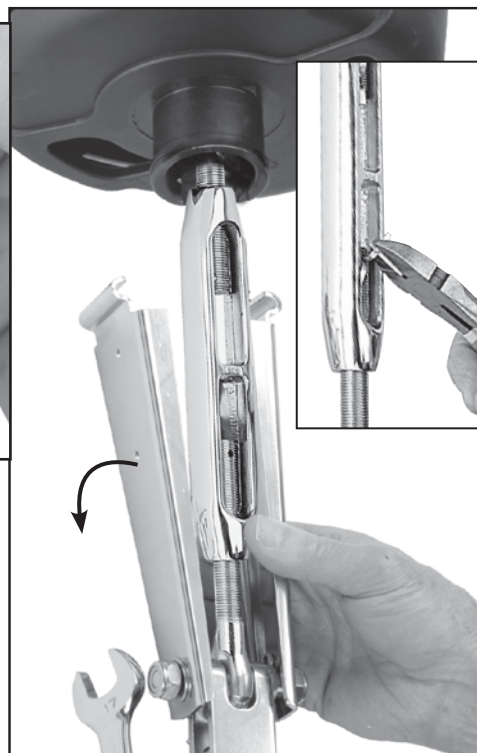
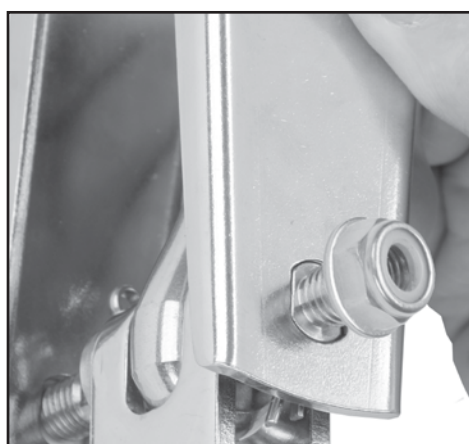
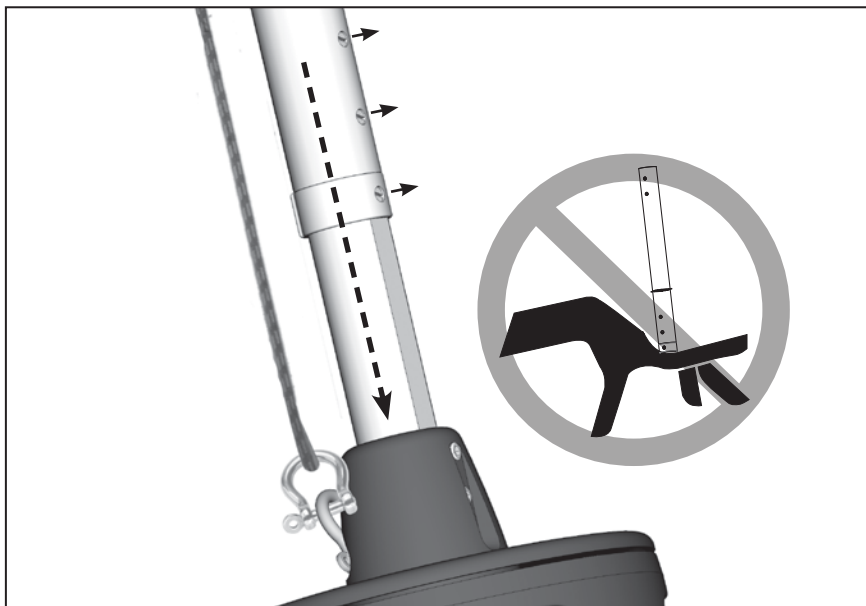



Clean

Keep unit clean. When you wash boat, flush unit with soap and fresh water. Occasionally lower sail and flush halyard swivel with soap and fresh water. Clean unit more thoroughly at least twice a year. First remove line (note direction on spool) and flush bearings with soap and fresh water. Clean foils with soap and water. Run scrap of luff tape up foil groove to clean.

WARNING! Parts can wear, loosen, or corrode and can break at load. Periodically inspect items listed below and any others as necessary. See www.harken.com/manuals General Warnings for additional safety information.

Inspect

- 1) Unit for signs of chafe, wear, or damage.
- 2) Screws on unit for signs of loosening or missing:
 - Foil screws – unroll sail to inspect.
 - Feeder screws – unroll sail to inspect.
 - Adjuster tube clamp screws
 - Collar screws
- 3) Foils to make sure they have not dropped into drum assembly.
- 4) Wire for signs of wear, unraveling, or loosening.
- 5) Lock nuts on leg kit for signs of loosening or missing.
- 6) Lower toggle for signs of wear, cracks, or corrosion.
- 7) Cotter pin at lower toggle to be sure it is securely splayed as shown.

Storage – Mast Down

In areas where it freezes, do not store system where water can accumulate in foils. When water freezes it will rupture aluminum. Store foils under cover, with grooves facing down or on an angle so water will run out.

Storage/Transporting

Do not store or transport system with drum assembly extending beyond mast. Remove masthead clevis pin and shift furler up so drum assembly can be strapped securely to mast. Some people remove drum assembly and halyard swivel for storage and transport.

After Storage or Transport

After storing or transporting unit, clean thoroughly, including ball bearings. See instructions above.

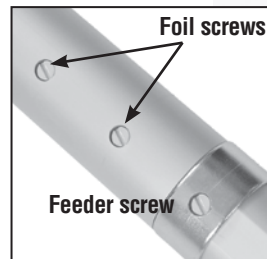
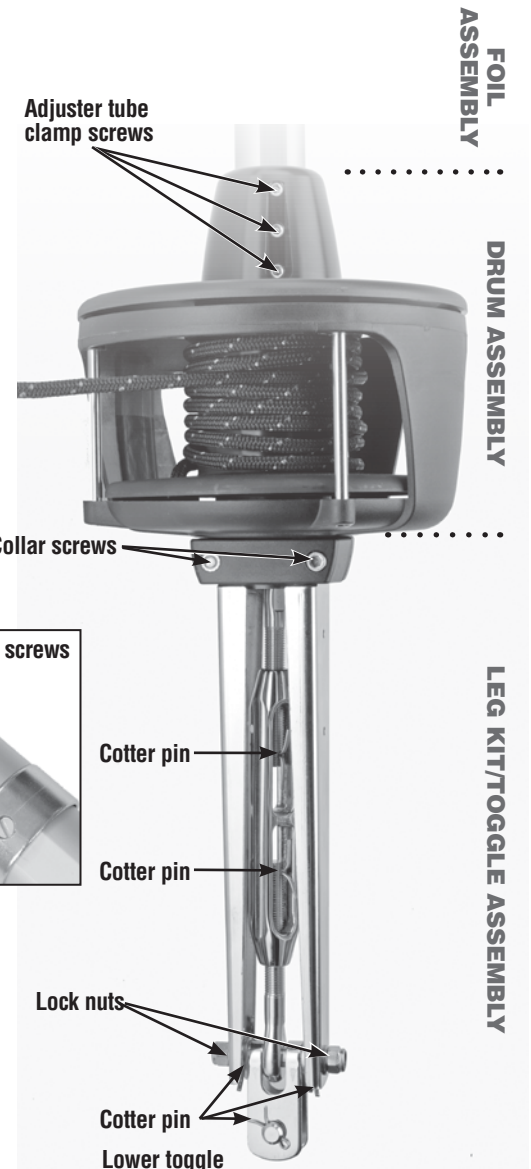

Problem	Probable Cause	Solution	
Sail will not furl or unfurl.	Jib halyard is wrapping around the headstay because halyard swivel is too low.	See "Check halyards" regarding optimal halyard swivel height. A wire pendant may be needed at head of sail to raise halyard swivel to proper height. Use a halyard deflector.	
	Jib halyard is too tight.	Ease jib halyard.	
	Spare halyard is wrapping in sail as it furls.	Secure spare halyards away from furling headstay by flipping them behind spreaders. Use a halyard deflector.	
	Salt or dirt in bearings.	Flush bearings with fresh water.	
	Furling line tangled in drum.	Overrides are best prevented by using a 7402 ratchet block as the last furling line lead to maintain proper drag on line while unfurling.	
	Stop knot catching.	Make sure knot is a single overhand and is pushed up inside spool.	
	Sail full of wind.	Luff completely before furling or reefing.	
	Sail flogging too much.	Release a short length of sheet, pull some furling line and repeat.	
	Jib sheets are not free.	Free jib sheets.	
	Foil out of drum assembly.	Reinstall foil in drum assembly and tighten adjuster clamp screws into holes.	
	No wraps of furling line on spool.	Remove sheets from furled sail. Rotate spool to wrap correct amount of line.	
Sail will not furl completely.	Line led through ratchet block backwards.	Rerun line.	
	Halyard swivel installed upside down.	Remount swivel correctly.	
	Insufficient furling line on drum.	Remove sheets. Rotate stay, wrapping as much furling line on drum as possible.	
	Too much line on drum.	Adjust amount of line on drum or change position of forward lead block to allow line to roll evenly on drum.	
	Spare halyard catching in sail as it furls.	Move halyards away from furling headsail as above.	
	Headstay rotates in jerks or elliptically.	Insufficient tension on headstay.	Tighten headstay and/or backstay to eliminate sag in headstay.
	Sail does not stay furled.	Sail not furled tightly on stay.	Maintain drag on sheets while furling.
		Furling line not secure.	Secure furling line.
	Sail will not go up.	Luff tape will not go into groove.	Check luff tape for fraying. Check luff tape size.
		Sail catching at feeder.	Have someone guide sail into feeder. Purchase prefeeder part no. 947.
Dirt in groove.		Clean groove.	
Sail will not raise completely or luff will not tension.	Halyard swivel is hitting end stop or trim cap screws.	Luff of sail is too long and must be recut. Consult sailmaker.	
	Angle between halyard and mast is too sharp and halyard is pulling too much to the rear.	Luff of sail may be too long. Consult sailmaker.	
Sail will not come down.	Halyard is wrapping on headstay.	Angle between headstay and halyard is too shallow and must be optimized. See commissioning "Halyard Wraps."	
Sun cover rolls up inside of sail.	Furling line is wrapped on spool in wrong direction.	Unfurl sail and lower it. Disconnect from furler. Note direction of line wrap on spool. Pull line from spool and rewind in opposite direction. Connect sail and hoist. See commissioning section of manual.	
Line is wearing on plastic drum assembly	Line is not led through guide posts.	Lead line into drum between guide posts.	

Loctite® is a trademark of Henkel AG & Company KGaA

Online Product Registration
www.harken.com/FurlingWarranty

Warranty
www.harken.com/manuals
 or call, write, email or fax Harken, Inc.,
 Pewaukee, WI USA

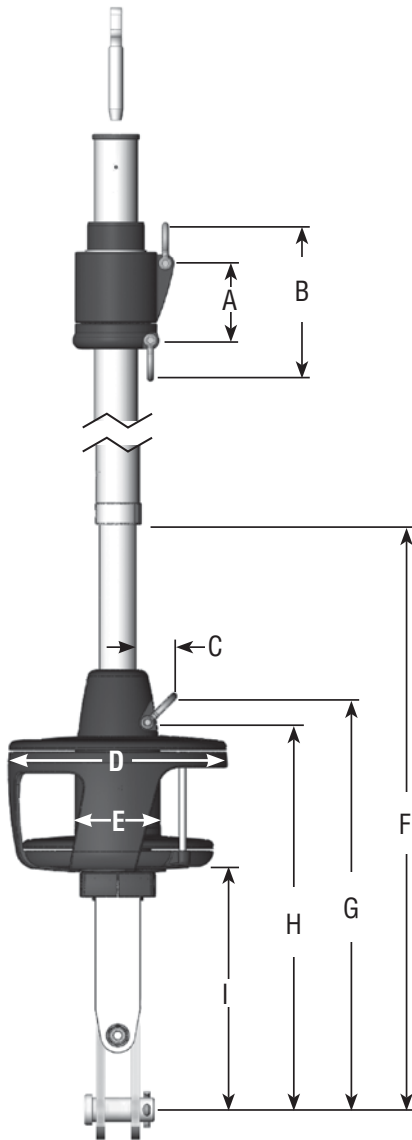

Luff Length

Note offsets above and below sail.

If luff of sail is not long enough to put halyard swivel near top of headstay foil, a pendant must be added (see page 26).

Tack Setback

Note setback for tack shackle and cut the sail accordingly.

Luff Tape Size - #6 (5/32" or 5 mm)

J - Finished luff tape size: 0.215" (5.5 mm)

K - Luff rope size: 5/32", 3/16" (4.8 mm)

L - Max Ø in sail groove: 0.24" (6 mm)

M - Gap in sail groove: 0.096" (2.4 mm)

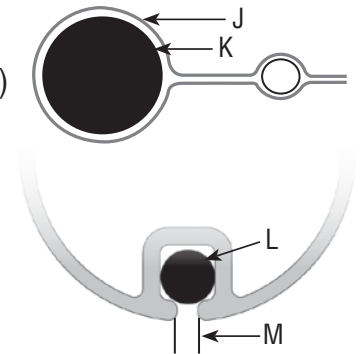

Luff Tape Length

Note feeder height and extend bottom of luff tape downward so it is below feeder. This will prevent luff tape from catching in feeder as sail is lowered.

Tack and Head Shackles

Make sure tack and head shackles fit sail rings. Minimum inside dimensions of standard head and tack shackles are:

Unit	A	B
2	13/4"	11/16"
	44 mm	17 mm
3	17/8"	13/16"
	48 mm	21 mm

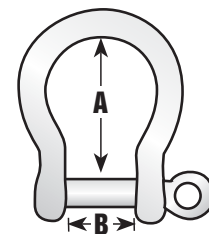

Sun cover

Sun covers may be installed on either side of sail. Be sure to match other sails in the customer's inventory.

	A	B	C	D	E	F Max*	F Min*	G	H	I
UNIT 2	7322.20 Short Leg Kit – 300 mm									
	37/8"	75/16"	2"	97/8"	35/8"	403/4"	25"	1215/16"	1113/16"	415/16"
	99 mm	185 mm	51 mm	(250 mm)	(97 mm)	(1034 mm)	(635 mm)	(329 mm)	(300 mm)	(125 mm)
	7322.22 Medium Leg Kit –									
	37/8"	75/16"	2"	97/8"	35/8"	477/8"	321/8"	201/16"	1815/16"	121/16"
	99 mm	185 mm	51 mm	(250 mm)	(97 mm)	(1217 mm)	(817 mm)	(510 mm)	(480 mm)	(307 mm)
7322.21 Long Leg Kit – 600 mm										
37/8"	75/16"	2"	97/8"	35/8"	529/16"	3613/16"	243/4"	235/8"	163/4"	
99 mm	185 mm	51 mm	250 mm	97 mm	(1335 mm)	(935 mm)	(629 mm)	(600 mm)	(425 mm)	
UNIT 3	7323.20 Short Leg Kit – 370 mm									
	51/8"	97/16"	21/8"	113/4"	43/4"	4215/16"	27"	161/16"	145/8"	61/2"
	130 mm	240 mm	53 mm	(298 mm)	(121 mm)	(1091 mm)	(686 mm)	(408 mm)	(370 mm)	(165 mm)
	7323.22 Medium Leg Kit –									
	51/8"	97/16"	21/8"	113/4"	43/4"	515/8"	3511/16"	243/4"	235/16"	153/16"
	130 mm	240 mm	53 mm	(298 mm)	(121 mm)	(1312 mm)	(907 mm)	(629 mm)	(590 mm)	(386 mm)
7323.21 Long Leg Kit – 740 mm										
51/8"	97/16"	21/8"	113/4"	43/4"	571/2"	419/16"	305/8"	293/16"	211/16"	
130 mm	240 mm	53 mm	(298 mm)	(121 mm)	(1461 mm)	(1056 mm)	(778 mm)	(740 mm)	(535 mm)	

* E Max and Min depend on foil position at adjuster tube.

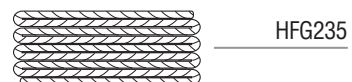
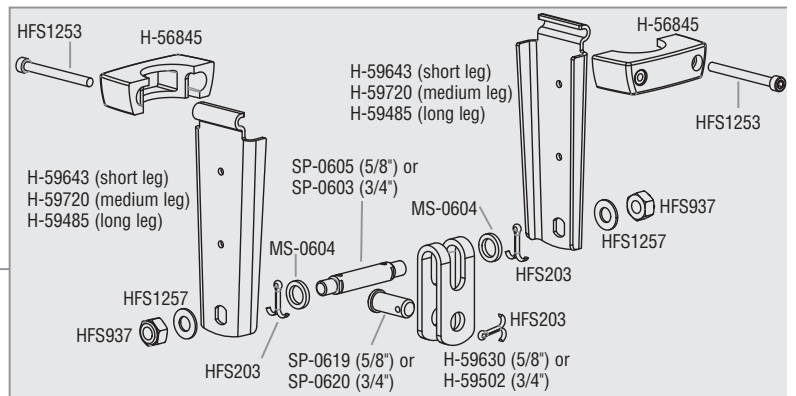
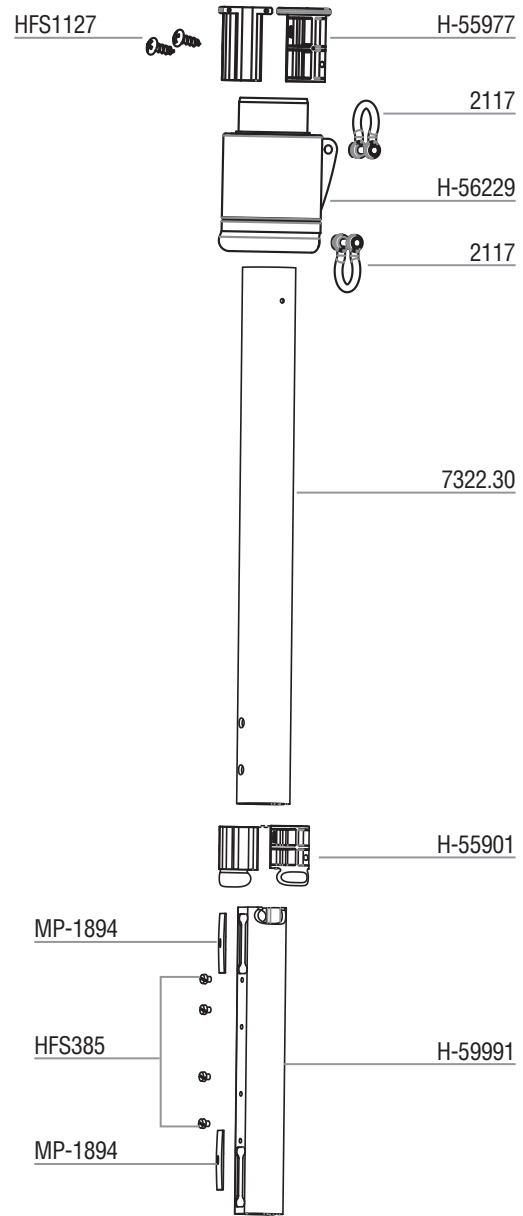
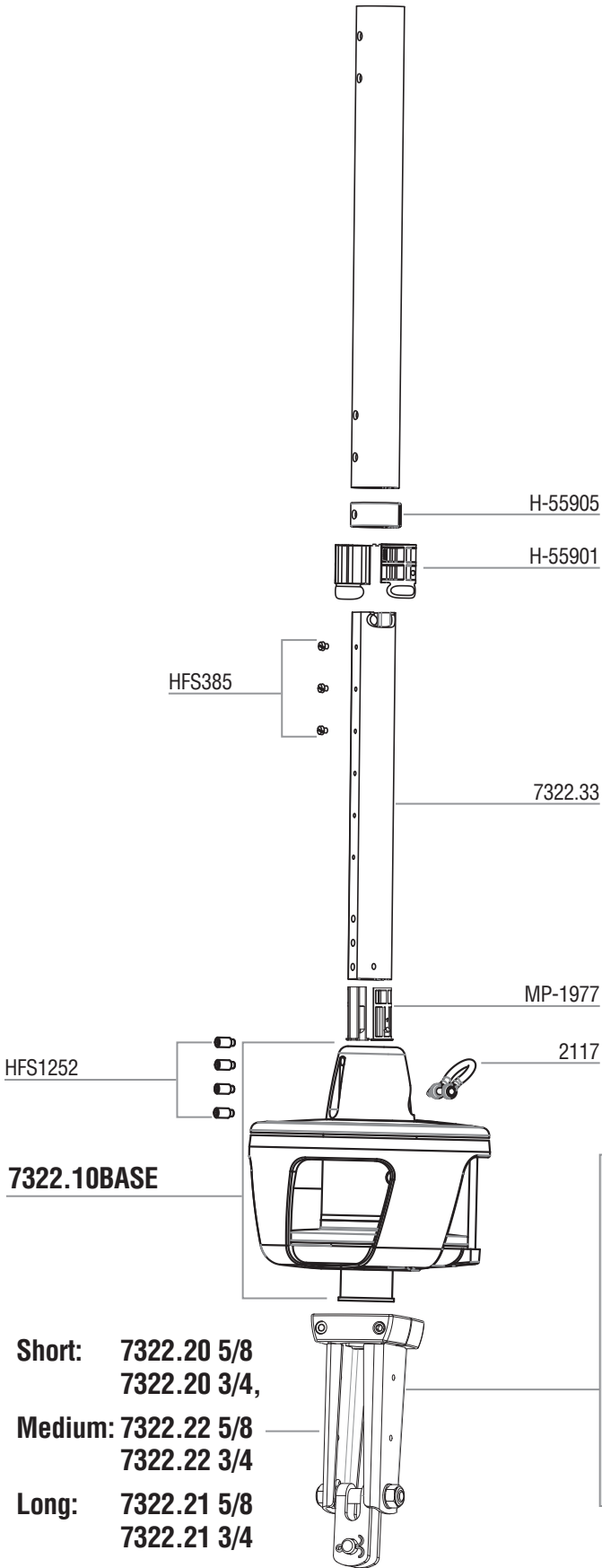

HARKEN®

Corporate Headquarters

N15W24983 Bluemound Rd, Pewaukee, WI 53072 USA
Telephone: (262) 691-3320 • Fax: (262) 701-5780
Web: www.harken.com • Online Catalog: www.harkenstore.com
Email: harken@harken.com

Harken Australia Pty, Ltd.

1B Green Street, Brookvale, N.S.W. 2100, Australia
Telephone: (61) 2-8978-8666 • Fax: (61) 2-8978-8667
Web: harken.com.au • Email: info@harken.com.au

Harken France

ZA Port des Minimes, BP 3064, 17032 La Rochelle Cedex 1, France
Telephone: (33) 05.46.44.51.20 • Fax: (33) 05.46.44.25.70
Web: harken.fr • Email: info@harken.fr

Harken Italy S.p.A.

Via Marco Biagi, 14, 22070 Limido Comasco (CO) Italy
Telephone: (39) 031.3523511 • Fax: (39) 031.3520031
Web: harken.it • Email: info@harken.it

Harken New Zealand, Ltd.

30-36 Fanshawe Street, P.O. Box 1951, Auckland 1001, New Zealand
Telephone: (64) 9-303-3744 • Fax: (64) 9-307-7987
Web: harken.co.nz • Email: harken@harken.co.nz

Harken Polska SP ZOO

ul. Rydygiera 8, budynek 3A, lokal 101, I piętro, 01-793 Warszawa, Poland
Tel: +48 22 561 93 93 • Fax: +48 22 839 22 75
Web: harken.pl • Email: polska@harken.pl

Harken Sweden AB

Main Office and Harken Brandstore: Västmannagatan 81B
SE-113 26 Stockholm Sweden
Telephone: (46) 0303 61875 • Fax: (46) 0303 61876
Mailing address: Harken Sweden AB, Box 64, SE -440 30 Marstrand
Web: harken.se • Email: harken@harken.se

Harken UK, Ltd.

Bearing House, Ampress Lane, Lymington, Hampshire S041 8LW, England
Telephone: (44) 01590-689122 • Fax: (44) 01590-610274
Web: harken.co.uk • Email: enquiries@harken.co.uk

**Please visit: <http://www.harken.com/locator.aspx>
to locate Harken dealers and distributors**