

HARKEN®

INSTALLATION SHEET

Big Boat Track Trim Caps • Control Blocks

Track: 3154, 3155, 3156, 3159

Trim Caps: 3157, 3158

End Controls: 3185, 3186, 3193

N15W24983 Bluemound Rd. • Pewaukee, WI 53072 U.S.A.

Telephone: (262) 691-3320 • Fax: (262) 701-5780

Web: www.harken.com • Email: harken@harken.com

Read instructions before cutting or mounting track.

It may be necessary to put trim caps, control blocks and traveler car on track before mounting. Slide control assemblies onto track with bumper facing car. Keep control assembly loose so it can be moved out of way when installing track.

Cutting Track

To cut track to length, make sure stop holes for control blocks do not interfere with holes for mounting track. If necessary, cut both ends of track (Figure 1).

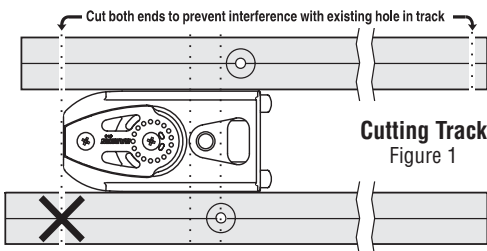

To determine correct track length, make sure track ends, without trim caps, are $\frac{13}{16}$ " (21 mm) from edge of cockpit coaming. This will allow water to pass (Figure 2).

Cockpit Installation of Traveller Car/Control Blocks

Slide control block onto track with bumper facing traveler car.

Keep control block loose so it can be moved when installing track. Add the traveler car and the second control block with the bumper facing toward the traveler car.

Mounting Track

Through-bolt using $\frac{5}{16}$ " (8mm) fasteners (flathead—low-beam; hexhead—high-beam).

Install Control Blocks

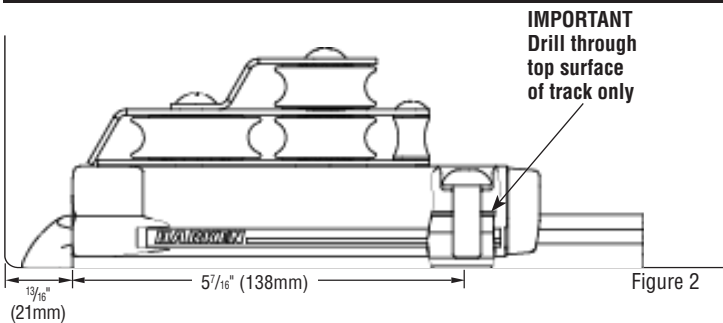

IMPORTANT: Drill $\frac{27}{64}$ " (10.5mm) hole only through top surface of track.

Do not use screw hole in control block as drill guide.

To mark hole, position control block flush with end of track. Drive mounting screw firmly against top surface of track, then loosen. Slide control block away. Start hole with centerpunch and drill hole through track top surface only.

Do not use screw hole in control block as drill guide. Secure control block to track by tightening screw into hole.

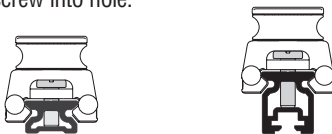

1846, 3154, 3155, 3156, 3159
Use 25mm (1") Screws

3156
Use 45mm ($\frac{13}{4}$ ") Screws

Installing Trim Caps

Remove burrs on track edges. Press 3157, 3158 trim caps in place.

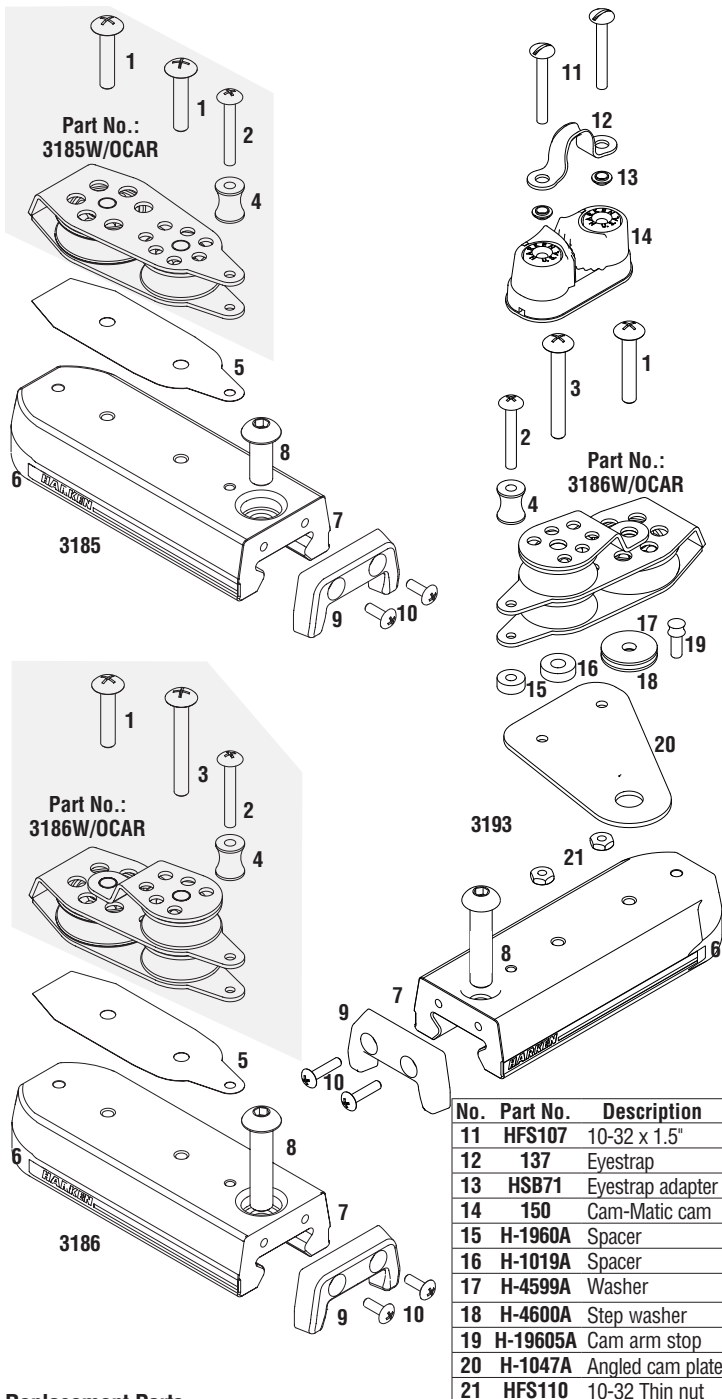

Replacement Parts

No.	Part No.	Description	No.	Part No.	Description
1	HFS541	Cheek block screws	7	H-38937B	End control body
2	HFS562	Becket screw	8	HBB172	Control Block Set Screw
3	HFS542	Cheek block screw		HFS1073	m10 x 1.5 x 25mm
4	H-19599A	Becket		HFS1074	m10 x 1.5 x 45mm
5	H-19601A	Mylar washer	9	H-38906B	Bumper
6	4306	Harken label	10	HFS347	Bumper Screws

Maintenance

Traveler Cars: Clean by frequently flushing with fresh water. Periodically clean car by squirting a detergent/water solution into center openings. Roll car back and forth to distribute evenly then flush bearings with fresh water.

Do not use spray lubricants because ball bearings may skid not roll. Apply one to two drops of McLube® OneDrop™ to ball contact surfaces of track. Roll car back and forth through OneDrop™ several times to distribute onto bearings. Wipe remaining OneDrop™ off track. OneDrop™ is preferred but you can also use one to two drops of a light machine oil. Too much oil attracts dirt.

Track: Clean with detergent and water.

Important! Exposure to some teak cleaners and other caustic solutions can result in discoloration of part and is not covered under the Harken warranty.

Warranty

For additional safety, maintenance and warranty information see www.harken.com/manuals or the Harken® catalog.