

HARKEN®

MKIV UNDERDECK JIB REEFING & FURLING

Unit 0

Installation Manual – Intended for specialized personnel or expert users

4427 05/15



Preassembly

Parts	4
Rigging parts check/tools	5
Dimensions/sailmaker's instructions	6
Rigging options/turnbuckle	7 – 8
Stay into foil options	8

Hub Assembly

Install hub assembly in bow	9
Underdeck lead block	10

Preassembly

Top foil length	11
Short top foil	12
Foil length check	13

Assembly

Foils/connectors	14 – 20
Halyard swivel	20
Torque tube assembly	21
Rod rigging	22
Attach turnbuckle/foils to boat	23 – 24
Feeder/final	25

Commissioning

Turnbuckle	26 – 27
Lead line to cockpit	28
Halyard swivel height/angle	29
Halyard restrainer/tension	30

Operation

Halyard/headstay tension	31
Raise sails/storm sails/reefing	32 – 33
Secure sail	33
Race conversion	33

Maintenance/Troubleshooting

Clean/inspect	34
Replace line	34
Storage/transporting/remove	34
Troubleshooting	35
Parts list	36 – 37
Drilling template	38

Please read these instructions carefully before installing, servicing, or operating the equipment.
This manual may be modified without notice. See: www.harken.com/manuals for updated versions.

PLEASE SAVE THESE INSTRUCTIONS.

Safety Precautions/Parts Description

Introduction

This manual gives technical information on installation and service. This information is **destined exclusively** for specialized personnel or expert users. Installation, disassembling, and reassembling by personnel who are not experts can cause serious damage to property, or injury to users and those in the vicinity of the product. If you do not understand an instruction, contact Harken.

The user must have appropriate training in order to use this product.

Harken accepts no responsibility for damage or harm caused by not observing the safety requirements and instructions in this manual. See Limited Warranty, General Warnings and Instructions in www.harken.com/manuals.

Purpose

Harken Jib Reefing & Furling systems are designed for rolling sails on sailboats to reduce sail size, or to completely roll so wind has little effect on the sail. Use of this product for other than normal sailboat applications is not covered by the limited warranty.

Safety Precautions



WARNING! This symbol alerts you to potential hazards that can kill or hurt you and others if you don't follow instructions. The message will tell you how to reduce the chance of injury.



CAUTION! This symbol alerts you to potential hazards that can hurt you and others if you do not follow instructions. The message will tell you how to reduce the chance of injury.



WARNING! Strictly follow all instructions to avoid potential hazards that may kill or hurt you and others. See www.harken.com/manuals for general warnings and instructions.

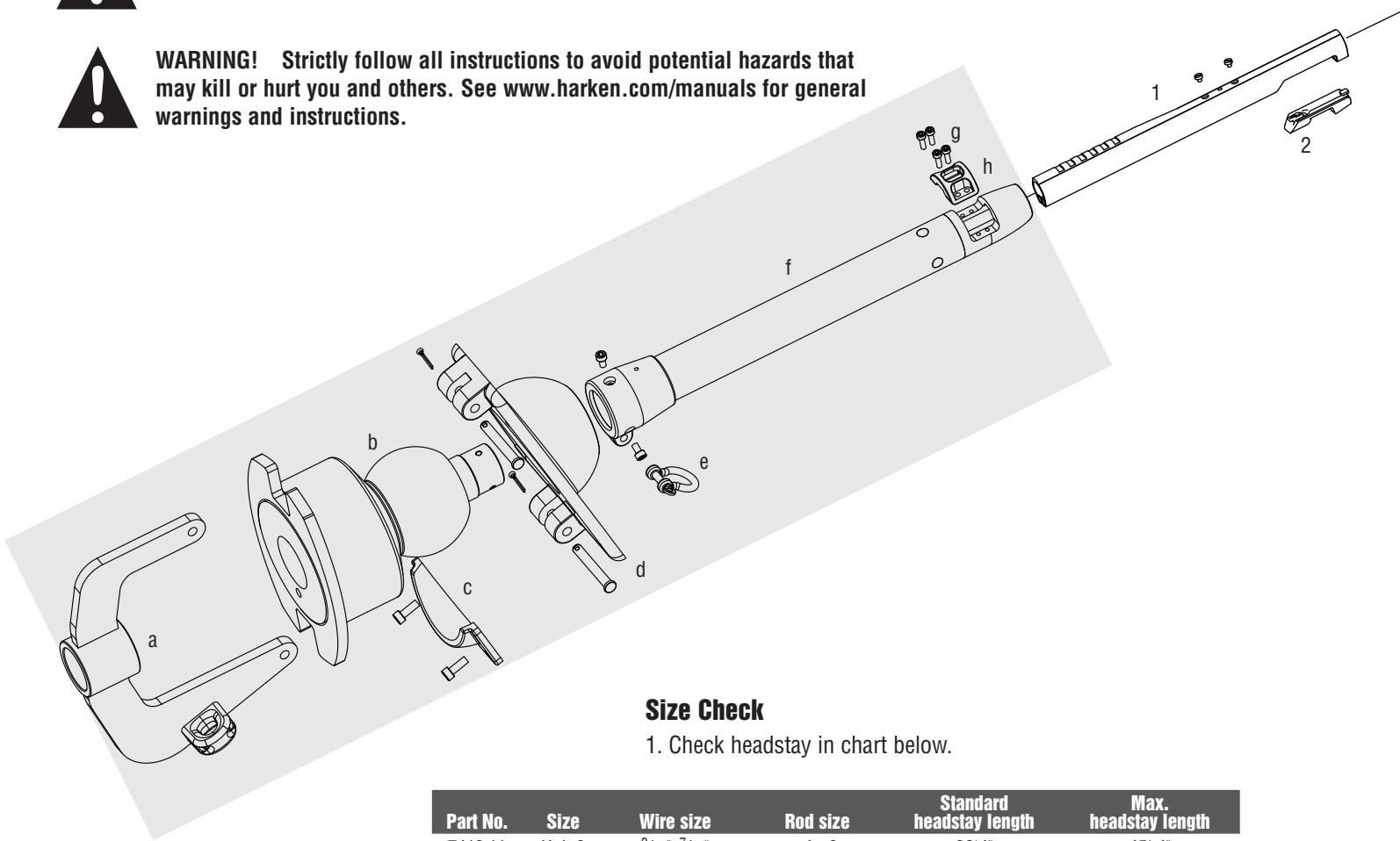

Size Check

1. Check headstay in chart below.

Part No.	Size	Wire size	Rod size	Standard headstay length	Max. headstay length
7410.11	Unit 0	3/16", 7/32" 5 mm; 6 mm	-4, -6 4.37 mm; 5.03 mm	38' 4" 11.7 m	45' 4" 13.8 m

Parts Descriptions

Hub assembly

- a) Bridge fairlead assembly
- b) Ball spool guard assembly

- c) Keeper
- d) Deck plate
- e) Tack shackle

- f) Torque tube
- g) Torque tube screws
- h) Foil clamp

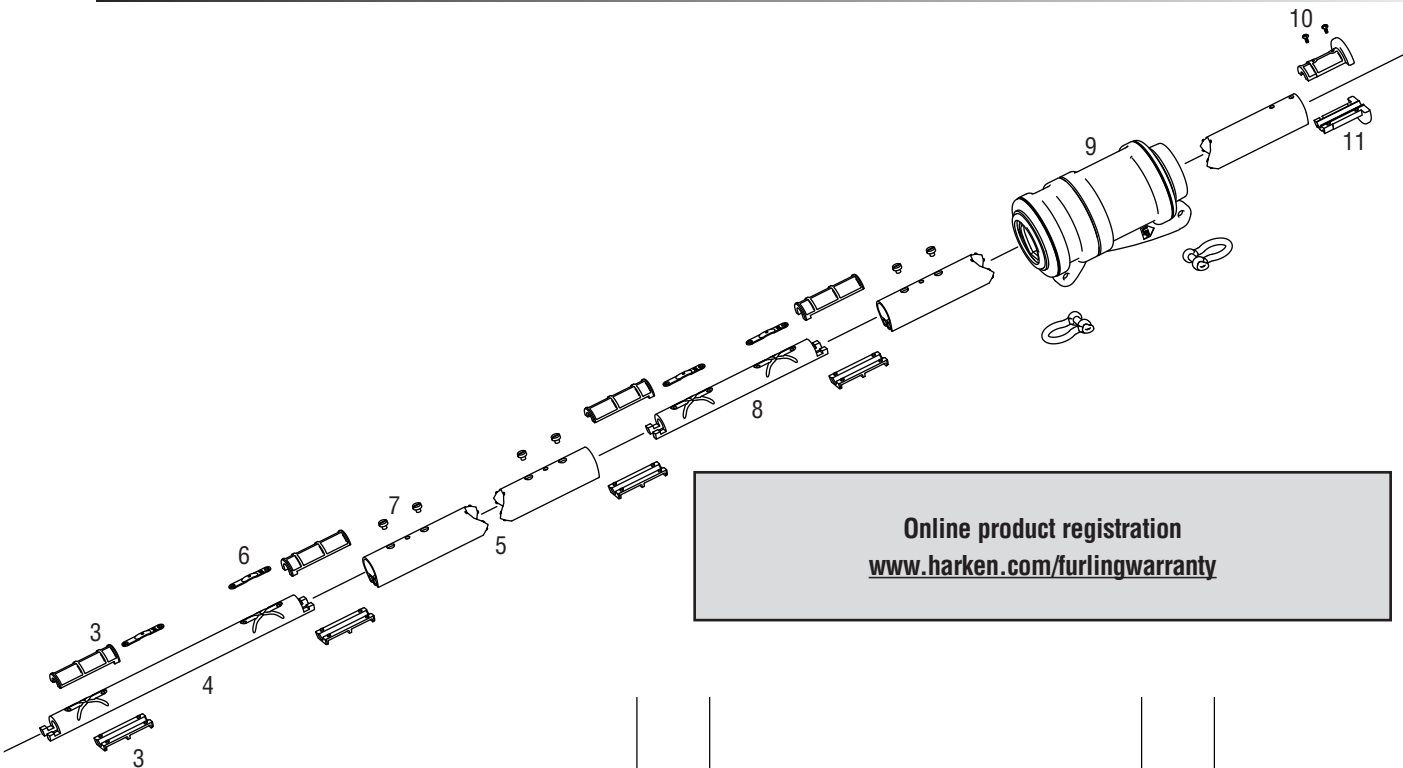

Online product registration
www.harken.com/furlingwarranty

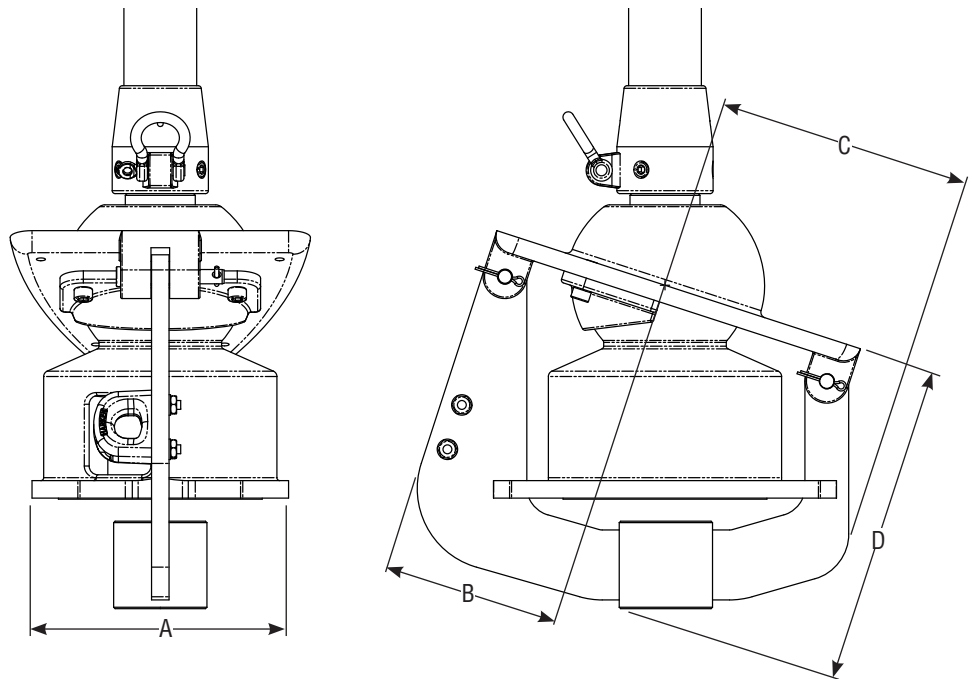

Unit	Part No.	A	B	C	D
0	7410.11	5 1/2" 140 mm	3 25/32" 96 mm	5 7/16" 138 mm	6 29/32" 175 mm

Will Drum Fit in Bow?

Note: See dimensions above. Unit requires a connection to Underdeck chainplate for stay loads. See page 38 for deck plate dimensions.

Furler Requires Drained Compartment

Harken's Underdeck furler is designed to keep much of the water from entering the bow compartment. Water will drip through the furler when it rains, or when sailing in heavy weather. The furling compartment must drain.

Upper Unit

- 1) Bottom foil
- 2) Feeder

3) Connector bushing

- 4) Bottom connector
- 5) 2.13 m (7') foil

6) Connector wedge

- 7) Connector screws
- 8) Connector

9) Halyard swivel

- 10) Trim cap screws
- 11) Trim cap



Line (not included with furler)

Note: Line is not included with furler. Drum of unit is smaller to allow it to fit into narrow bow sections. If overlapping sails are used, standard diameter line will fill up drum and jam furler. To prevent this, use small diameter, high strength line at forward end, and have a rigger add a cover at aft end where line is handled.

Line Specifications

Forward Ø	Min break strength	Aft Ø
3/16" (5 mm)	1300 lb (590 kg)	1/4" (6 mm)

Main Components

Part No.	Quantity	Description
HFG951	1	Hub assembly with foil clamp
H-39923	1	Halyard swivel

Foils (Standard Package)

Part No.	Quantity	Description
7410.30	5	7'(2.13 m) foil
7410.33	1	2'(610 mm) bottom foil

Tools

Quantity	Description
1 each	2.5, 3, 5 mm hex keys

Loctite is a registered trademark of Henkel AG & Company KGaA.

Other Components

Part No.	Quantity	Description
7410.31	4	6.5" (165 mm) connector
7410.32	1	10" (254 mm) bottom connector
HFG294	1	Connector bushing set (10-H-42067/10-H-42068)
HFG298	1	Plastic connector wedge set (12-H-39625)
HFG341	1	Foil screw set (26-HFS1105)
HFG679	1	Trim cap set (H-37335/H-37336)
HFG629	1	Trim cap screw set (3-HFS1126)
947	1	Prefeeder
H-39713	1	Feeder with screw and tab
2110	3	6 mm bow shackles
HFG725	1	Injector, 1 oz. 5200 adhesive (HFG722)
HFG739	2	Red Loctite adhesive (for foil screws)

1. Turnbuckle components are not included and must be purchased separately.
2. Rod rigging requires Harken rod adapter stud.
3. Order Harken lead blocks and one additional 7403 if necessary. Fits 25 mm (1") stanchions.
4. Furling line - Use 5 mm (3/16") to 6 mm (1/4"). To figure line length, measure the distance from the furler to the furling cleat. Add 4.5 m (15').



7404 lead block kit (sold separately).



Recommended furling compartment lead blocks.

Unit	Turning	Through-deck
0	349	131

ROD RIGGING
Harken rod adapter stud required (sold separately).



7420 -4
7421 -6
Rod adapter stud.

Adhesive Alert

MKIV furlers are shipped with 3M 5200 adhesive. Use adhesives on dry connectors and foils using the special injection system described in the assembly section. Parts might immediately be exposed to rain. Cure is best at 70 F (22 C) with 50% humidity. Do not apply at temperatures below 40 F (5 C) and above 100 F (38 C).

Although adhesive has not cured, it will remain in place on foil joints whether they are left on the ground, or raised up on boat. Foils can be raised immediately after assembly and sails fitted.

Note: A small amount of adhesive might bulge out of injection ports. If possible, let system sit for several days before sailing. If adhesive gets on sails, remove using acetone. For faster-curing adhesive, purchase 4200 Fast Cure.

Note: Damaged foils can be repaired. Use a hand-held propane torch to heat joints until foils can be pulled apart.

Tools You Will Need



Unit	Drill Ø
0	1/8" (3 mm)

Use 6 mm bolts and washers to mount deck flange. To figure bolt length, add 10 mm (3/8") to deck thickness. **Minimum thread engagement must be 9 mm.**

1. Long tape measure	6. Side cutters	11. Center punch	16. Hole saw 110 mm (4 1/4")*
2. Short tape measure	7. Rat-tail file	12. Rigging or black tape	17. Deck sealant
3. Power drill	8. Hex keys (provided)	13. Scissors	18. Box-end wrench
4. Drill bits 3 mm (1/8")	9. Slotted/Phillips screwdrivers	14. Metal straight edge	19. 6 mm bolts, nuts, and washers
5. Hacksaw	10. Needle-nose pliers	15. Hammer	

*Requires some beveling of bottom edge of deck hole to provide a good fit. Alternatively, a smaller hole may be used to fashion a socket in deck to conform to ball shape. This may improve appearance and reduce amount of water that enters. A 115 mm (4 1/2") hole saw may also be used if no beveling is desired.

Luff Length

Note: Offsets above and below sail.

A shorter luff may be required if a halyard restrainer is necessary (page 30).

If luff of sail is not long enough to put halyard swivel near top of headstay foil, a pendant must be added. Page 29.

Tack Setback

Note: Setback for tack shackle and cut the sail accordingly.

Luff Tape Size

All units require #6 (5 mm or 6/32") luff tape.

Luff Tape Length

Cut off top of luff tape so it is 450 – 600 mm (18 – 24") below head of sail. This allows head to lag behind rest of sail to help flatten sail. It will also help head to roll more smoothly.

Note: Extend bottom of luff tape downward so it is below feeder. This will prevent luff tape from catching in feeder as sail is lowered.

Tack and Head Shackles

Make sure tack and head shackles fit sail rings. The minimum inside dimensions of standard head and tack shackles are:

Unit	A	B
0	1 1/16" (27 mm)	1/2" (13 mm)

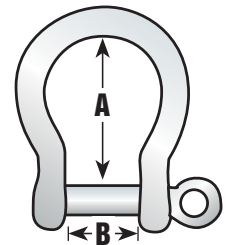

Sun Cover

7410.11 furls in one direction only.

IMPORTANT! Sun cover must be installed on starboard side of sail.

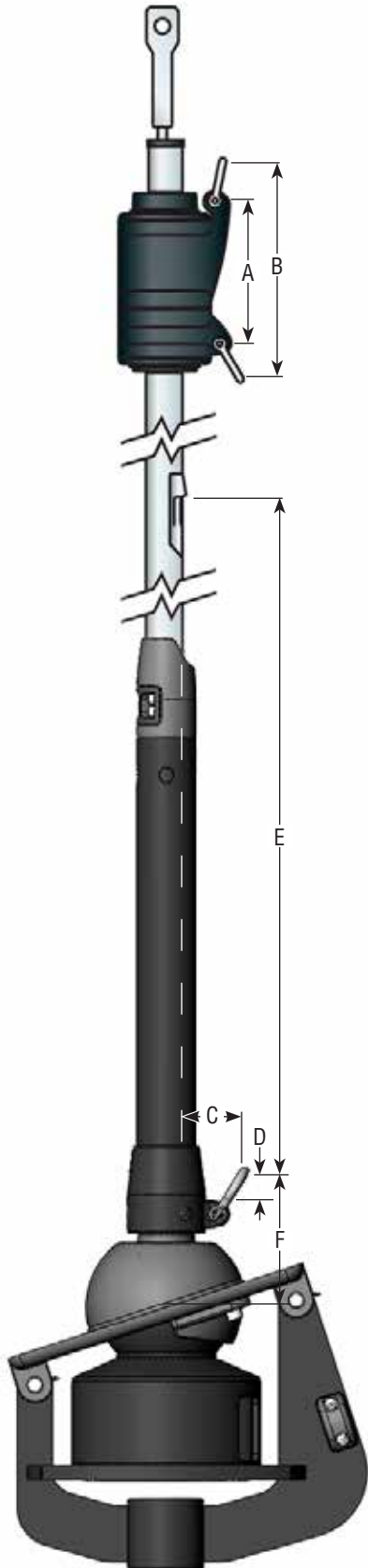

Unit	Part No.	A	B	C	D	E	F
0	7410.11	3 3/4" 96 mm	6 1/4" 158 mm	1 19/64" 33 mm	15/64" 6 mm	34 5/16" 817 mm	3 19/32" 91.5 mm

The stay runs up the center of the MKIV Unit 0 Underdeck furler. It does not attach to the furler in any way. Choose one of the following three (3) turnbuckle locations based upon diameter of turnbuckle body and access to the turnbuckle belowdeck. The interior of the furler components are shown below.

Unit	A	B	C	D	E	F	G	H
0	1 7/16" 36.4 mm	10 1/8" 258 mm	1" 25.4 mm	7 1/2" 190.5 mm	5 1/2" 140.5 mm	1 7/8" 47.6 mm	2 5/16" 58.6 mm	1 1/2" 38.1 mm

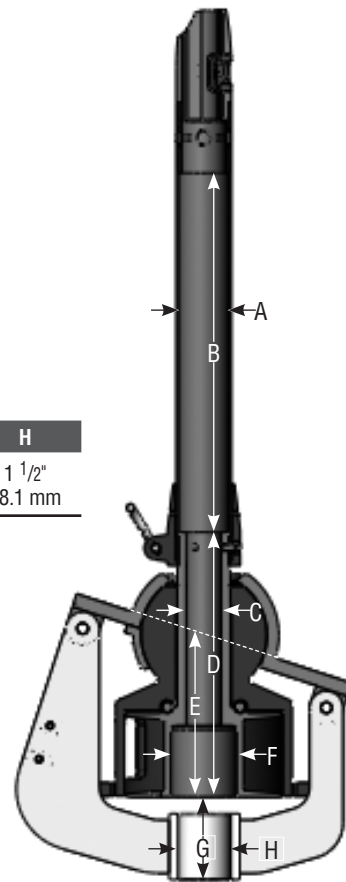

Turnbuckle Options

Turnbuckle Below Furler

Make sure that the upper stud wrench flats are accessible. If necessary, the bridge fairlead assembly can be lowered below the turnbuckle to allow access to wrench flats.





Turnbuckle inside torque tube

Set up a pendant below, making sure to have a turnbuckle toggle.



Use a swage-to-swage turnbuckle located just above the lower unit. Check turnbuckle fit inside torque tube. Requires a “third hand” to adjust.



Turnbuckle above swage

On smaller size wires—4 mm (3/16”); a small turnbuckle should fit. Check dimensions above for clearance.

Options for Stay Insertion

1. Swage stud at end of wire.
2. Open end of wire and install Norseman or STA-LOK® stud after foil is assembled.
3. Rod adapter nosepiece for Harken rod adapter stud: Threaded nosepiece must have a positive lock as well as adhesive. Use Harken stud with cotter pins. Page 22.

STA-LOK is a registered trademark of Sta-Lok Terminals, Ltd.



WARNING! Using a threaded nosepiece with only adhesive at the upper rod eye terminal can result in headstay system failure. Make sure there is a mechanical lock.



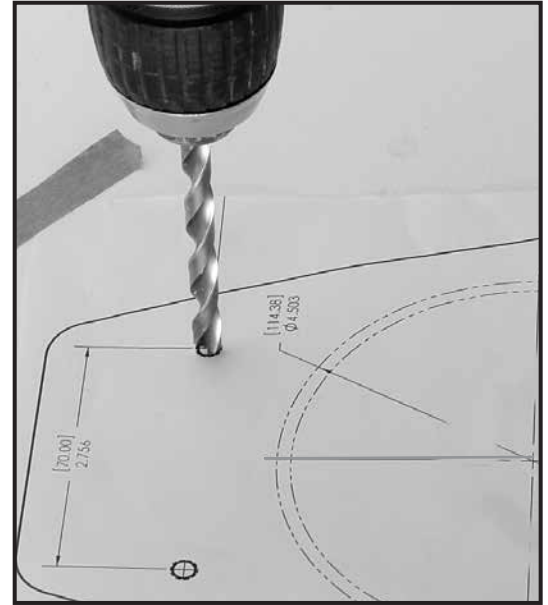
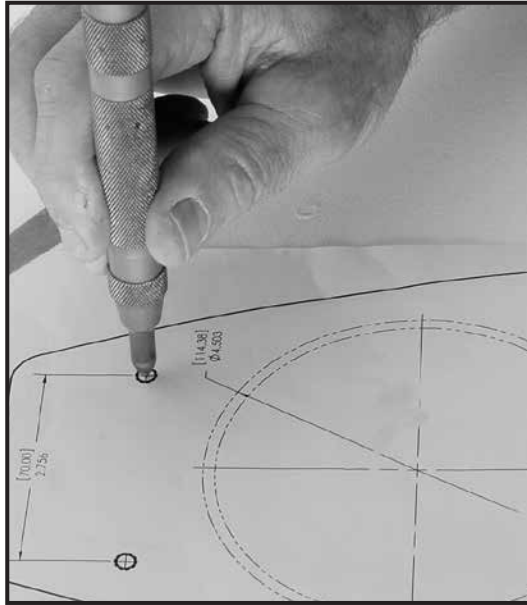
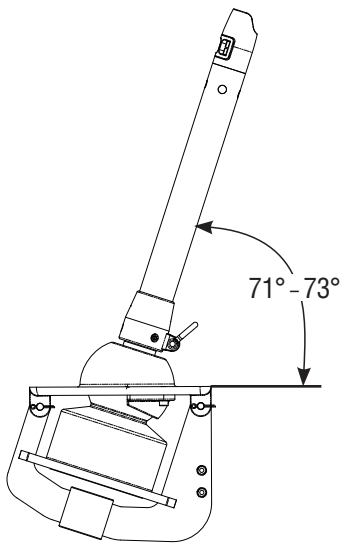

Note: Deck plate angle matches a stay angle of 72° when compared to deck. Angles can vary between 71° and 73°. If deck does not fall within these angles, shims must be made using structural adhesive to avoid excessive pressure on deck and deck bearings.

Carefully locate center point in deck to locate deck plate. Line from mast to Underdeck chainplate must intersect this center point. Mark center fore/aft and athwartships line. Use template to mark four outer holes and center pilot hole. Make sure closer pair of holes is forward. **Mark center hole for drilling large hole.**

Once you are certain hole is located in line with chainplate and any required shimming is done, drill hole 90° to deck.

Make sure hole is large enough so deck plate bears against deck. It is better to make hole slightly smaller and file opening larger to fit. Use template to mark large hole and bolt holes. Use hole saw to drill deck.

Tip: After pilot drill bit clears deck, drill final hole from bottom using pilot hole to line up hole drilled from top. This will prevent glass from chipping.



Tip: Run line through fairlead and deadend line into spool before mounting lower unit.

Use 6 mm screws, washers, locknuts and deck sealant to fasten lower unit to deck. **Note:** There must be a minimum of 9 mm (3/8") thread engagement into deck flange.



Assembly

Under-Deck Lead Block

Mount lead block so furling line is 90° to hub assembly.



Mount through-deck block. Be sure to angle it toward stanchion lead block.



Measure A and add to this chart and length chart below		
	Inches	mm
A		
B	2/5*	10*
E	24	610
F	14	359
G		
Total A+B+E+F+G		

*Add 25 mm (1") if using a halyard deflector.

Make sure upper measurement points of A and pin-to-pin are the same.

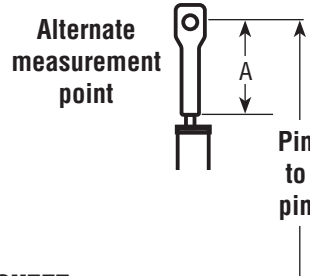

TOP FOIL LENGTH WORKSHEET

1	Pin-to-pin length											
2	Subtract ABEF	-										
3	Result (pin-to-pin - ABEF)											
4	Subtract D	-										
To find "D" pick number from chart below that is closest to, but not greater than total from Step 3.												
<table border="0"> <thead> <tr> <th>Inches</th> <th>mm</th> </tr> </thead> <tbody> <tr> <td>3 X 84 = 252</td> <td>3 x 2133.6 = 6400.8</td> </tr> <tr> <td>4 X 84 = 336</td> <td>4 x 2133.6 = 8534.4</td> </tr> <tr> <td>5 x 84 = 420</td> <td>5 x 2133.6 = 10668</td> </tr> <tr> <td>6 x 84 = 504</td> <td>6 x 2133.6 = 12801.6</td> </tr> </tbody> </table>			Inches	mm	3 X 84 = 252	3 x 2133.6 = 6400.8	4 X 84 = 336	4 x 2133.6 = 8534.4	5 x 84 = 420	5 x 2133.6 = 10668	6 x 84 = 504	6 x 2133.6 = 12801.6
Inches	mm											
3 X 84 = 252	3 x 2133.6 = 6400.8											
4 X 84 = 336	4 x 2133.6 = 8534.4											
5 x 84 = 420	5 x 2133.6 = 10668											
6 x 84 = 504	6 x 2133.6 = 12801.6											
Example—If result from step 3 is: 500 inches "D" = 420 inches 12,000 mm "D" = 10,668 mm												
5	Result (C) top foil length											

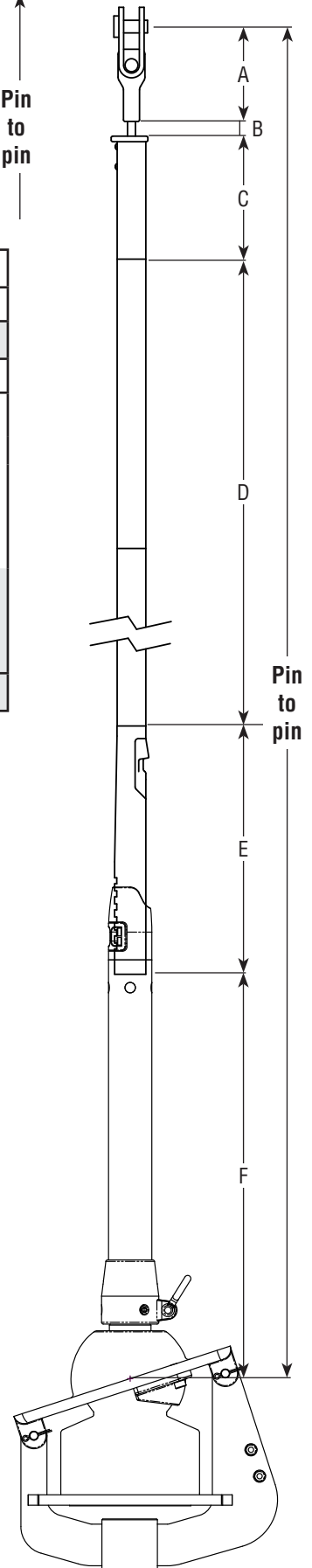

UNIT 0

Length Check

After completing worksheet above, fill in A, C and D below. Add "A" through "F" to confirm total equals your pin-to-pin measurement.

Length Chart		
Dimensions	Inches	mm
A Center of pin to bottom of terminal		
B Bottom of terminal to top of foil	2/5*	10*
C Top foil length		
D Number of foils _____ x 84" (2133.6 mm)		
E Bottom foil	24	610
F Bottom of foil to underside of deck	14	359
Pin-to-pin length		

*Add 25 mm (1") if using a halyard deflector.

If top foil is shorter than 177.8 mm (7"), use one of the following techniques to ensure sufficient bearing surface for the foil in the area of the halyard swivel.



162 mm (6 3/8") No special treatment required.



159 - 117 mm (6 1/4" - 4 5/8") Do not use plastic bushing above top connector.



114 - 89 mm (4 1/2" - 3 1/2") Do not use plastic bushing above top connector. Shorten top of connector and if necessary shorten trim cap.

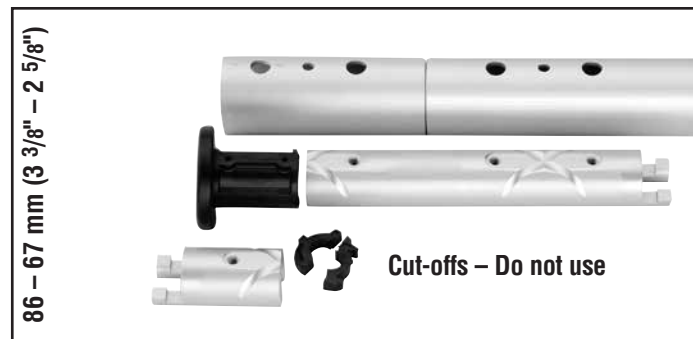

86 - 67 mm (3 3/8" - 2 5/8") Do not use plastic bushing above top connector. Cut connector right at cross formed by glue dispersion channels. Use single foil screw in top foil only.



63 - 13 mm (2 1/2" - 1/2"). Shorten top foil and adjoining full-length foil so two (2) screws are used to assemble joint instead of four (4). Do not use plastic bushings above top connector.

Top foil length from worksheet	1. Initial top foil cut length.	2. Cut through middle hole in top foil.* Resulting top foil length	3. Shorten full length adjoining foil by cutting through middle hole.*	4. Shorten connector. Length	5. Shorten trim cap.
2 1/2" (63 mm)	5 5/8" (143 mm)	4 1/16" (103 mm)		3 1/4" (83 mm)	No
2" (51 mm)	5 1/8" (130 mm)	3 9/16" (90 mm)		3 1/4" (83 mm)	No
1 1/2" (38 mm)	4 5/8" (117 mm)	3 1/16" (78 mm)		3 1/4" (83 mm)	No
1" (25 mm)	4 1/8" (105 mm)	2 9/16" (65 mm)		3" (76 mm)	Yes
1/2" (13 mm)	3 5/8" (92 mm)	2 1/16" (52 mm)		2 3/4" (70 mm)	Yes

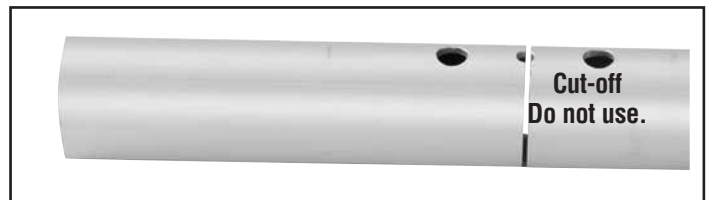

*To allow for saw cut, position blade so upper half of middle hole is preserved.



Under 13 mm (1/2") eliminate top foil and run foil higher in drum assembly.

Confirm foil length by laying foils alongside stay with turnbuckle components and torque tube. Pull stay out straight.

Line up bottom foil so foil clamp is just above or below center of notches in bottom foil.

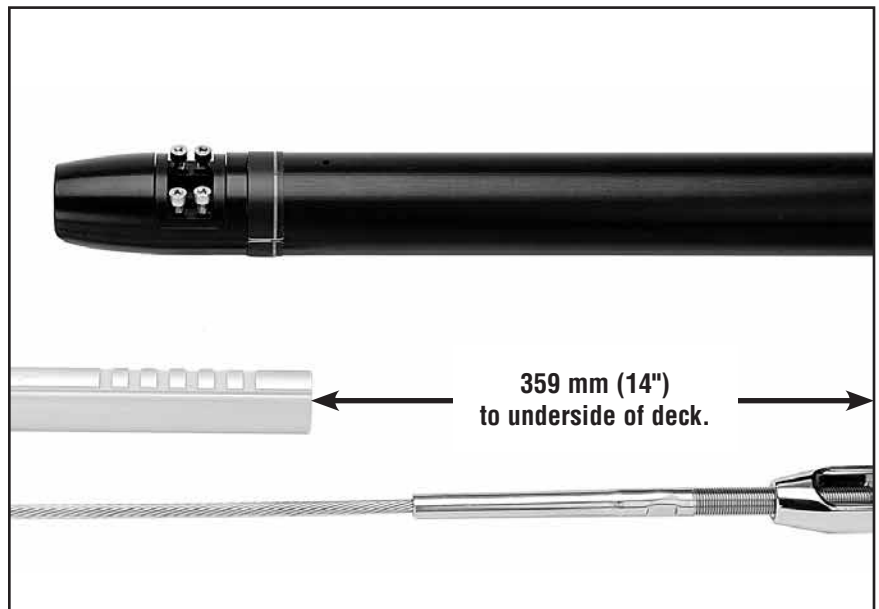

Note: Position top foil so that with top cap the foil will ride below terminal. If wire fitting at top of stay is swage, foil must ride just below shoulder of swage. Mark cut line on foil. Wrap tape around foil as a guide so cut is straight.

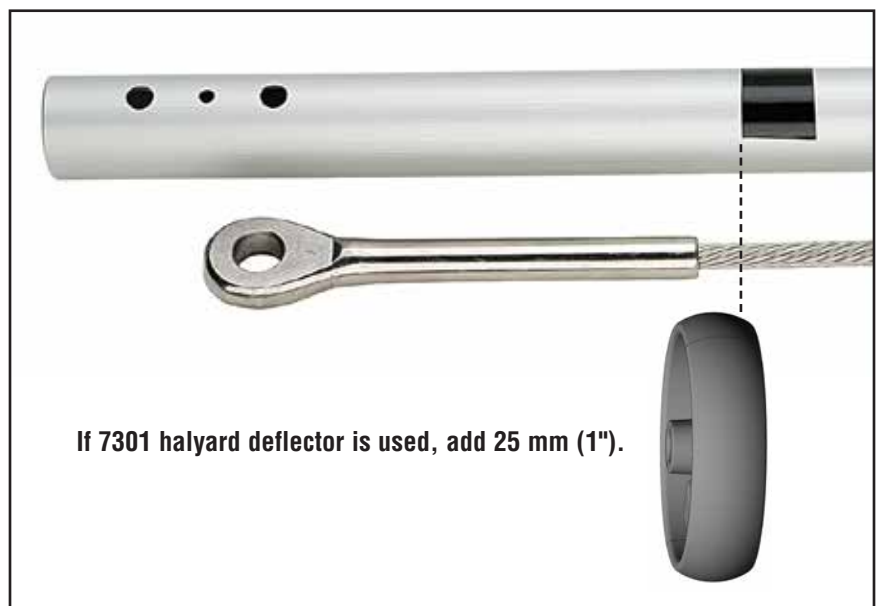

Cut foil to length using hacksaw.



Deburr inside edge using rat-tail file.

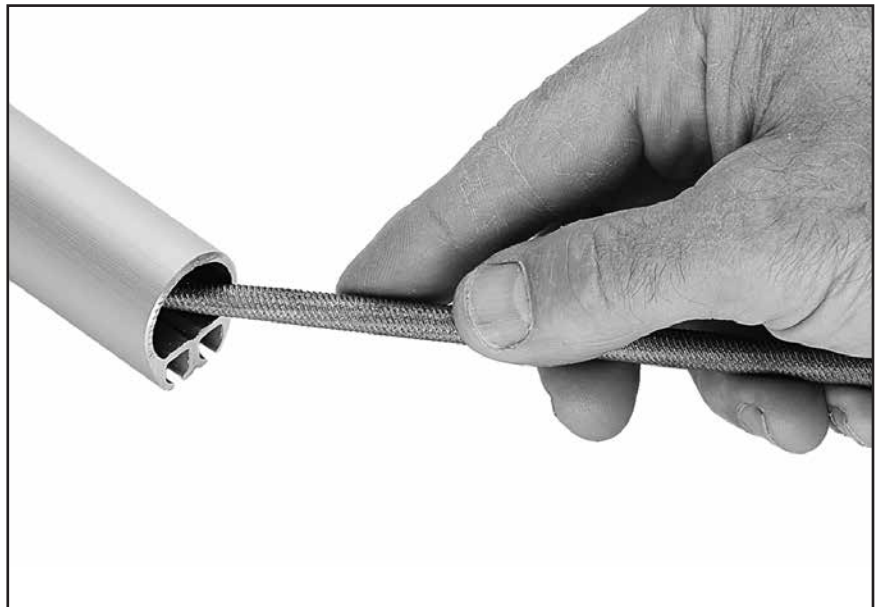

Prepare top foil for drilling.

Tip: Mark top foil to distinguish from cut-off piece.

Scribe line on top of foil to mark drill holes. Lay top foil alongside cut-off piece and use a flat metal object (i.e. metal ruler) to scribe top line of foil.



Cut out template at right. Line up template with top of foil and scribed line. Tape in place. Use a center punch to mark holes.

Check center punch marks to confirm they are 5 mm ($3/16$ ") and 20 mm ($13/16$ ") from top of foil.

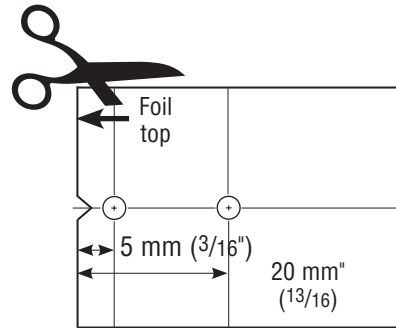

Drill two (2) 3.2 mm ($1/8$ ") holes for trim cap.



Lay top foil in line with others. Slide stay into top foil and down line of foils or slide each foil up stay.



Install trim cap. Place each side over wire.

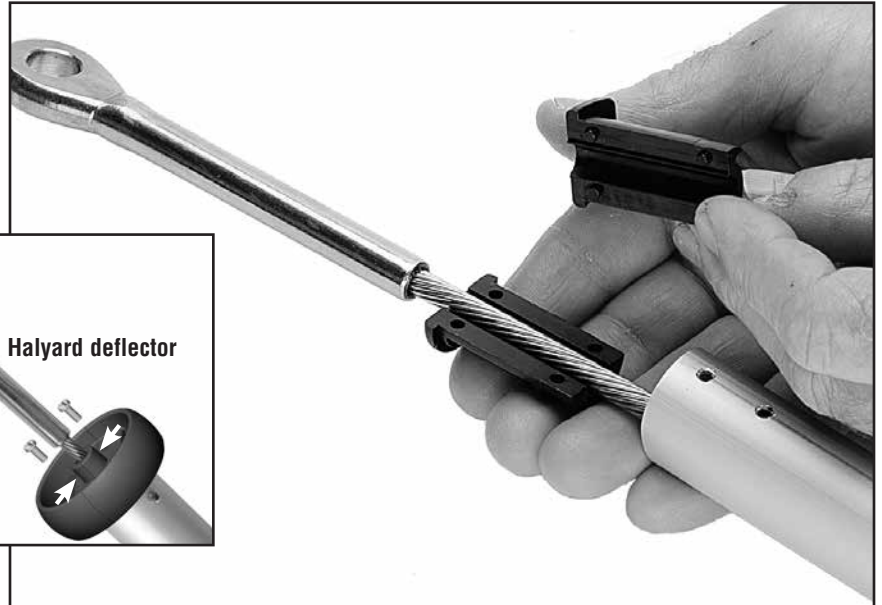
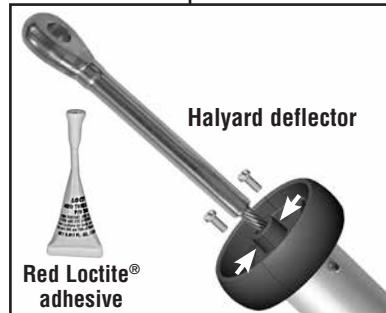

Loctite is a trademark of Henkel AG & Company KGaA.

Push trim cap into foil to start, then tap in using hammer. Install trim cap screws.



Place halves of plastic bushings on stay so hooked part of longer section faces out.

Tip: With foil screw holes up as shown below, place longer half of bushing with hook on upper half.



Slip connector on wire, mating hook of plastic bushing with connector.



Put a drop of red Loctite® adhesive into screw holes.

Loctite is a trademark of Henkel AG & Company KGaA.



Hold plastic wedge in place with thumb as you insert into foil. Line foil holes with connector screw holes.



Loading Injector with Adhesive

Tip: In cooler weather, keep sealed adhesive in pocket to keep warm. Use instructions below to fill injector less than half way; you will only use a small amount of adhesive. Refill if needed but do not keep open sealant for long periods. Use adhesive within 3 hours.

Use cap of adhesive to break seal. Remove injector tip cap and plunger. Hold injector at an angle with applicator tip facing down. Squeeze adhesive into tube so lower half of injector is full as shown. Keep tip free of sealant to let air inside.

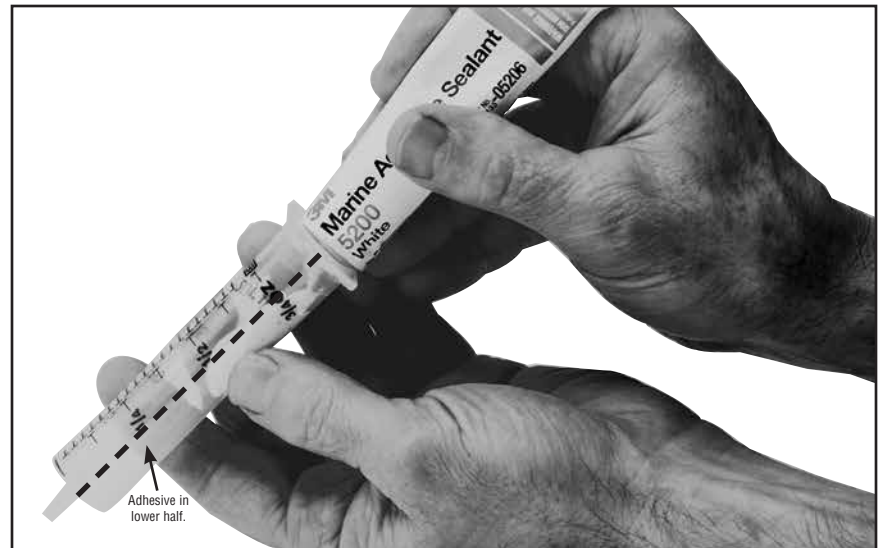

Start plunger into injector and immediately hold upright so plunger is down and applicator tip is up.

As sealant runs down toward plunger, an air pocket will form near tip. Push plunger to evacuate air. You are now ready to begin injecting adhesive.

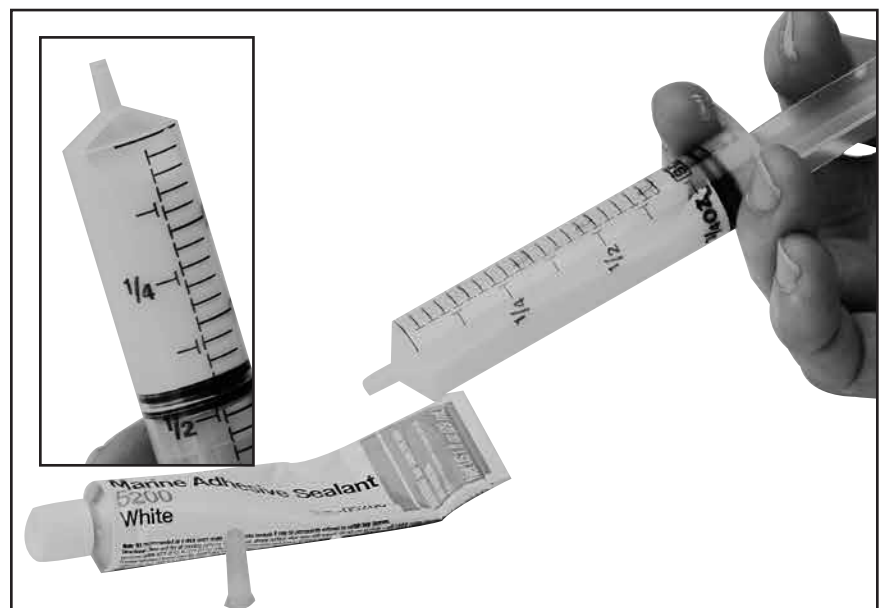

Inject only a small amount of adhesive into middle hole. Unit 0 will take 1/4 to 1/3 of a graduation mark. Do not press tip of injector into hole. Back-off slightly while injecting.

Tip: When you see a small amount of adhesive enter one of the screw holes, stop. You have applied enough adhesive.

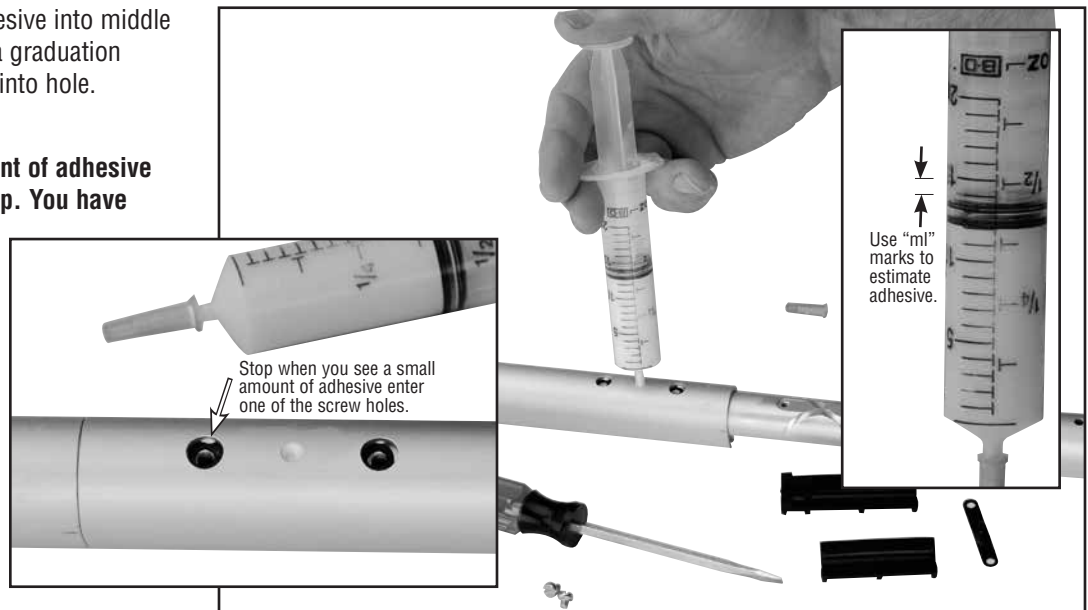

Tighten screws into connector holes. Make sure a drop of red Loctite® adhesive entered each screw hole. If not, apply to screw.

Loctite is a trademark of Henkel AG & Company KGaA.

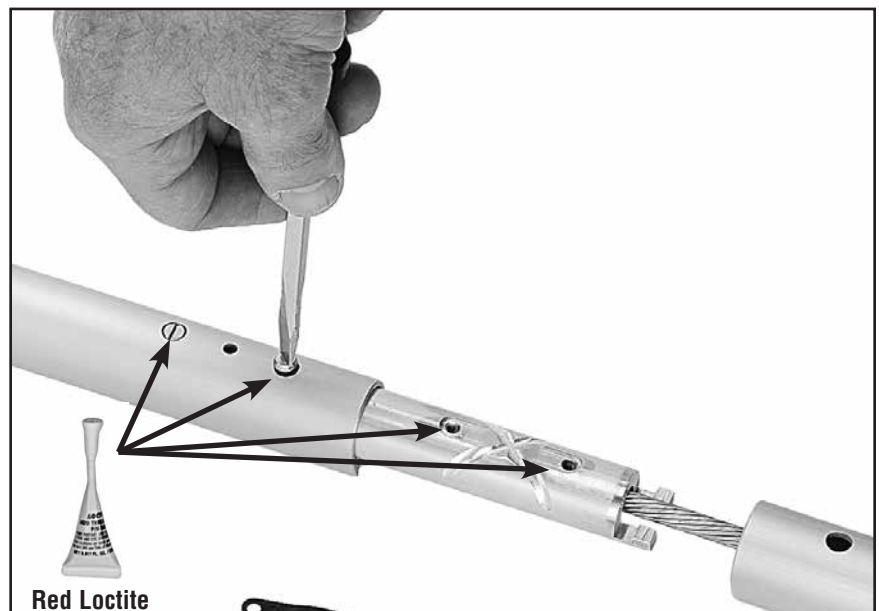

Use bushings, connector, wedge, and adhesive in other screw hole and insert into other foil.

Use 1/4 to 1/2 ml. of adhesive.



Assembly

Bottom Foil/Connectors/Halyard Swivel

Continue installing connectors and wedges.
Make sure to use adhesive in screw holes.

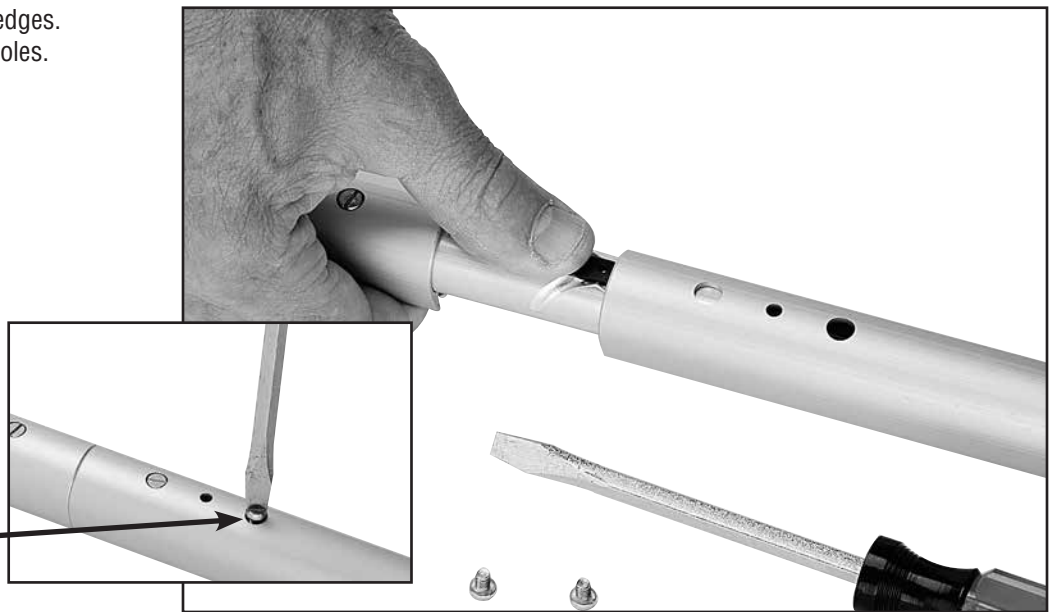

Continue assembly. Use bottom connector
to assemble bottom foil.

Loctite is a trademark of Henkel AG & Company KGaA.

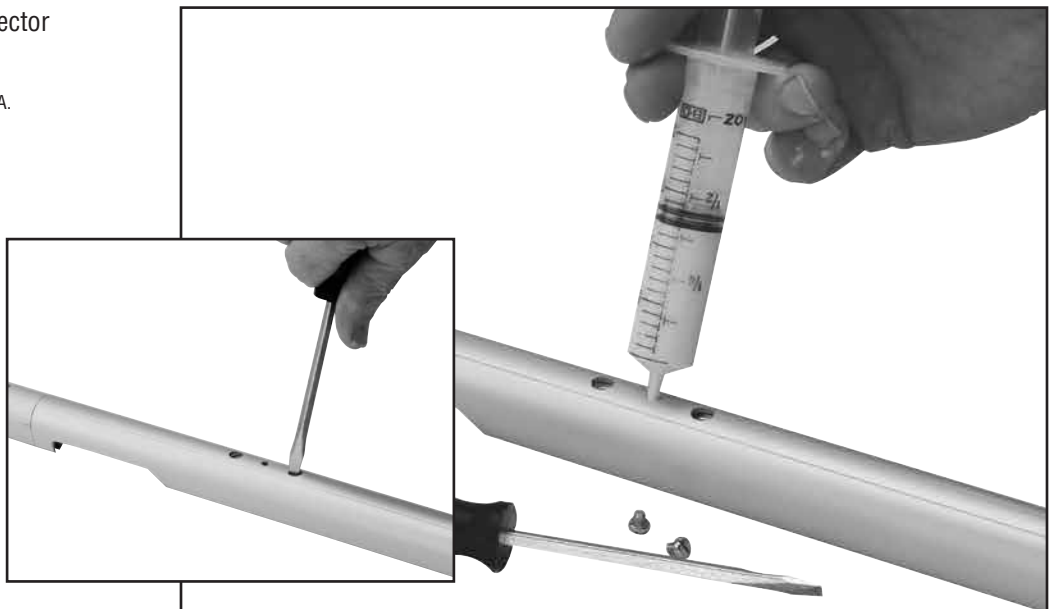

Slide halyard swivel onto foil above feeder window.
Make sure taller "half" is up as shown.



Loosen foil clamp screws at top of drum assembly.



Slide drum assembly onto foils.

Tip: Face clamp downward so it clears foil notches during installation.



Temporarily clamp torque tube to top of bottom foil, leaving feeder gap partially exposed as shown at right. Gap will be used to rig a foil system lifting line.



G
N
I
G
R
I
G
G
I
N
G
R
O
D
R
O
D

Apply a few drops of red Loctite® adhesive to threads of nosepiece.

Screw main threaded stud portion onto bronze nosepiece until flats align with two cotter-pin holes in terminal body.

Tip: Turn nosepiece completely into threaded stud portion. Flats will be close and may only require a small half turn to align with cotter pin holes.

Loctite is a trademark of Henkel AG & Company KGaA.



Insert two cotter pins and spread. Clean excess Loctite from terminal body using care to ensure there is no red Loctite on threaded stud.

Thread turnbuckle to stud protruding from foil. Assemble turnbuckle.

Note: If using STA-LOK® or Norseman stud, you must use a washer above stud as shown below.

STA-LOK is a registered trademark of Sta-Lok Terminals, Ltd.

Tip: Rig a large round plastic wash basin below furler to catch any parts that may be lost overboard.



Carefully raise foil and stay up onto boat. Raise foils using line attached to feeder gap as shown.

Adjust turnbuckle. Secure with cotter pin.



When stay length is set, use side cutters or needle-nose pliers to bend cotter pin to secure turnbuckle.





Assemble torque tube using the three (3) screws at the base.

Loosen foil clamp while holding torque tube and carefully lower into place.

Note: Do not remove screws, just loosen them.

Check foil height at top. Set and secure using hex key. Top of trim cap should be about 11 mm (7/16") to bottom shoulder of terminal.



Tip: Do not remove foil clamp screws to adjust foil. Loosen screws, hold foils, and bring clamp away from foils. Adjust and reclamp.



Slide halyard swivel above feeder. Place feeder in foil recess. Push screw down so tab catches under foil.



Tighten screw.

Note: Screw will turn with some difficulty. It is plastic coated to prevent loosening from vibration.

Important: When removing screw, loosen no more than one (1) full turn. Slide screw up and remove feeder.

Have extra cotter pins on hand to replace used ones at base of unit and for turnbuckle. Determine if the turnbuckle is located belowdeck or inside torque tube. If it is located inside, follow these steps:

Rig a screw catcher.

Hold foils and loosen torque tube screws until you can pull clamp part way out in order to lower foils. Lower foils.

Remove the three (3) screws at the base of the torque tube.

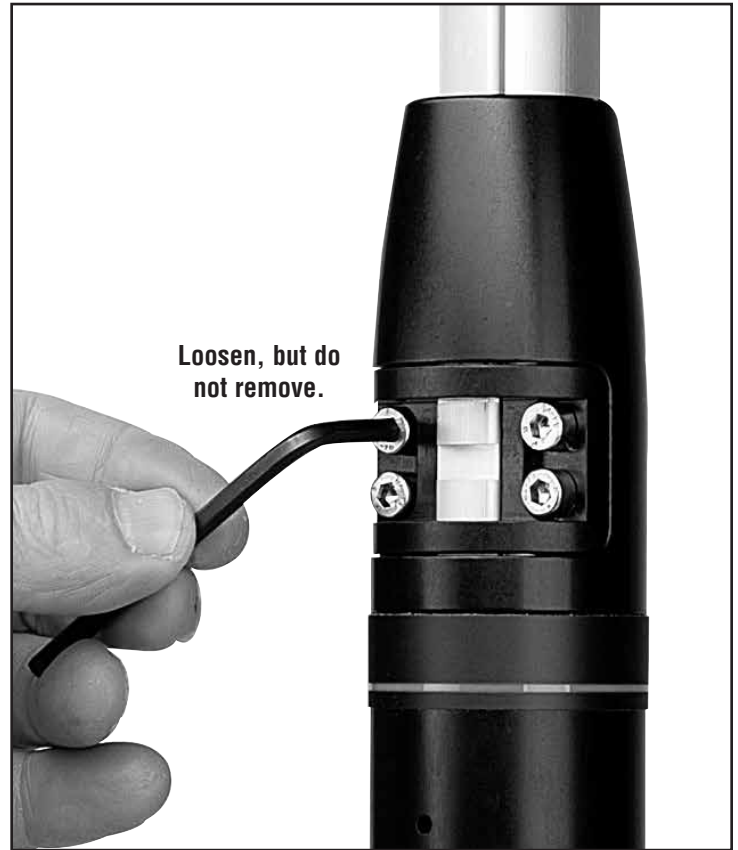



Check location of turnbuckle. It may be belowdeck under the hub assembly. If it is inside the torque tube, follow this procedure:

Slide torque tube onto foil and clamp just below top of feeder gap as shown. Use halyard to lift foil assembly.



CAUTION! To avoid injury, make sure drum assembly and foils are securely lifted using a halyard before adjusting turnbuckle.

Reassemble torque tube to lower unit. Lift foils so top is 11 mm ($7/16$ ") below upper terminal.

Slide foil clamp into foil notches and tighten screws to secure.



Adjust turnbuckle.

Feed the line through bullseye and into spool. Run down into deadend hole located on the lower flange of the spool and add a stop knot. Tie an overhand or figure-8 knot in the end. Set up lead block so line runs perpendicular to drum when it leaves bullseye.

The bullseye can correct small differences in line angle. Lead line aft using ball bearing blocks where line makes a turn more than 30 degrees. Install cleat.

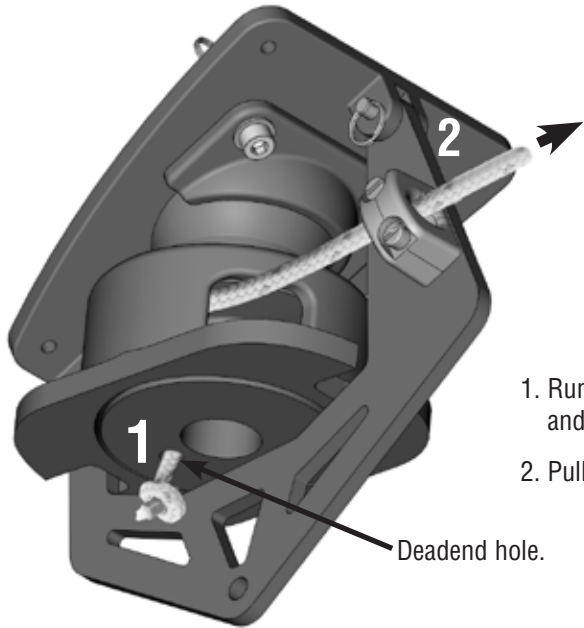

1. Run line out of hole in bottom of spool and tie a single overhand knot.
2. Pull knot back up to seat at hole.

Rotate the drum clockwise to charge the spool. Wind 3 – 4.5 m (10 – 15') of line on spool.

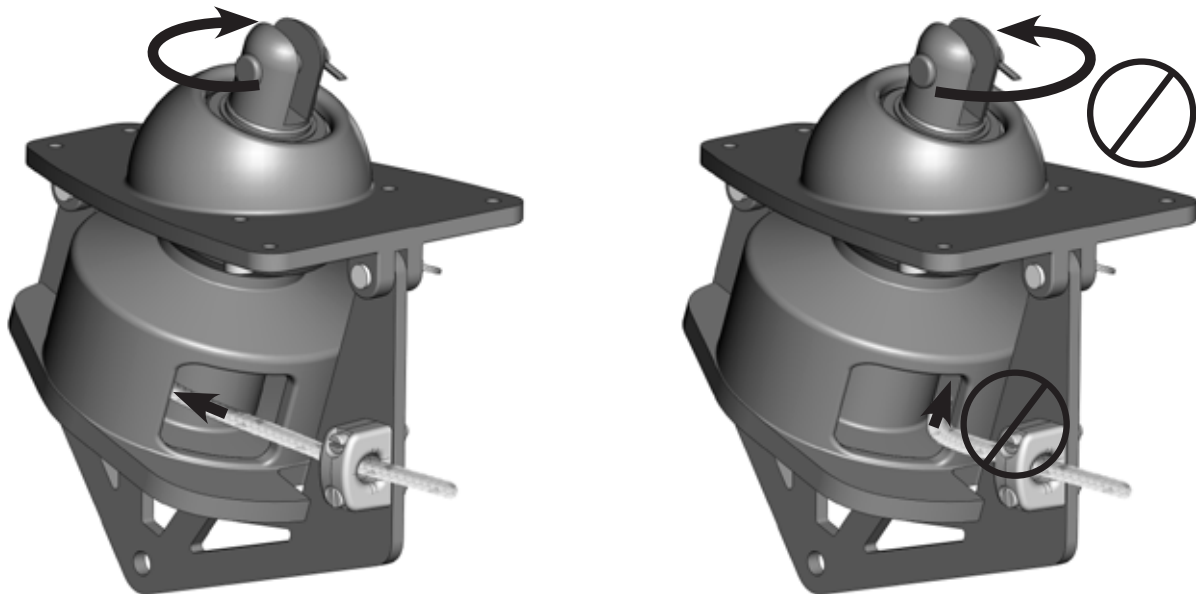

IMPORTANT! Make sure that the sun cover, if used, is installed on the starboard side of the sail.

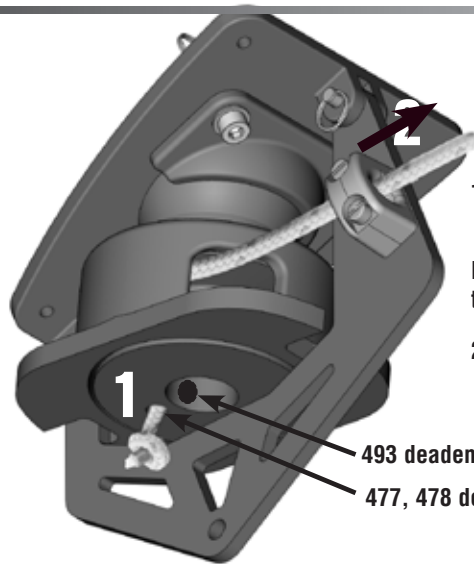

1. Run line out of hole in bottom of spool and tie a single overhand knot.

Note: On the 493 the deadend hole is in the hub.

2. Pull knot back up to seat at hole.

Counter-clockwise furling direction

Rotate the drum clockwise to charge the spool. Wind 10–15 ft (3–4.5 m) of line on spool.

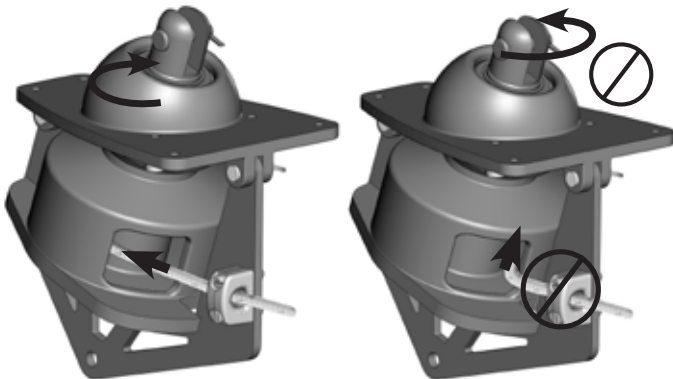

Clockwise furling direction

Rotate the drum counter-clockwise to charge the spool. Wind 10–15 ft (3–4.5 m) of line on spool.

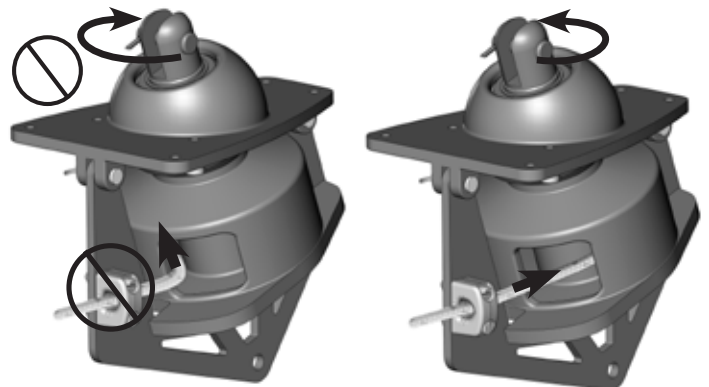

Commissioning

Upper Swivel

Attach upper swivel to jib halyard. Fasten head of unfurled jib to upper swivel and attach tack to the top of drum. Hoist sail with halyard, snug it up, and cleat. When using hoistable swivel, attach head of sail to shackle.

Operation

Unfurling/Furling

To furl jib, pull the furling line to roll sail up around its own luff. To unfurl, uncleat furling line and pull jib sheet.

Maintenance

Inspect/Clean

Inspect

- 1) Unit for signs of chafe, wear, or damage.
- 2) Rigging components for signs of stress corrosion.
- 4) Turnbuckle below drum or inside torque tube for signs of loosening.
- 5) Headstay tension for signs of loosening.
- 6) All clevis pins, locking rings, and cotter pins to make sure they are secure.
- 7) Inspect wire for signs of wear or unraveling.

Halyard Wrap

The most serious problem with furling systems occurs when the jib halyard wraps around the headstay foil. Halyard wraps will keep you from furling or unfurling, and can cause serious damage to the unit and the halyard.



WARNING! In severe cases, a halyard wrap can cause loss of control of boat and/or headstay can break suddenly. Make sure halyard is clear of top foil before using system.

To prevent wraps, the halyard must exert a slight pull to the rear. This allows the foils to turn while halyard remains stationary.

Prevent Halyard Wraps



WARNING! Sail must be fitted to foil length before using to prevent halyard wraps and possible headstay loss.

1. Halyard swivel should be within top 100 mm (4") of foil unless a halyard restrainer is used.
2. Halyard must pull slightly to rear ($8 - 10^\circ$).
3. Halyard must be snug, but not too tight.

If halyard wraps, do not force unit to turn. Attempt to open sail by carefully furling in and out a little at a time. If sail will unfurl, lower it by releasing jib halyard. Severe halyard wraps can only be cleared by going aloft and freeing halyard.

If sail will not furl or unfurl, try to remove jib sheets and manually wrap sail around headstay.

Testing at dock does not indicate halyard angle is correct. In wave action, halyard can wrap if lead angle is not correct. The $8 - 10^\circ$ diverging angle shown at right is critical.

Pendants

If sail luff is not long enough to position halyard swivel properly, you must add a pendant. Pendants should be made of plastic-coated wire and be permanently attached so sail height will be correct. Adjustable-length pendants are not acceptable, as they might not be adjusted correctly during a sail change.

1. Raise sail, but do not attach tack shackle.
2. Position halyard swivel correctly near top of headstay.
3. Secure halyard.
4. Tie a piece of rope to sail tack.
5. Lead line through tack shackle on furling drum.
6. Tension sail.
7. Measure distance from tack shackle to sail tack and permanently attach pendant of this length to head of sail.
8. Repeat procedure for every jib in your sail inventory.

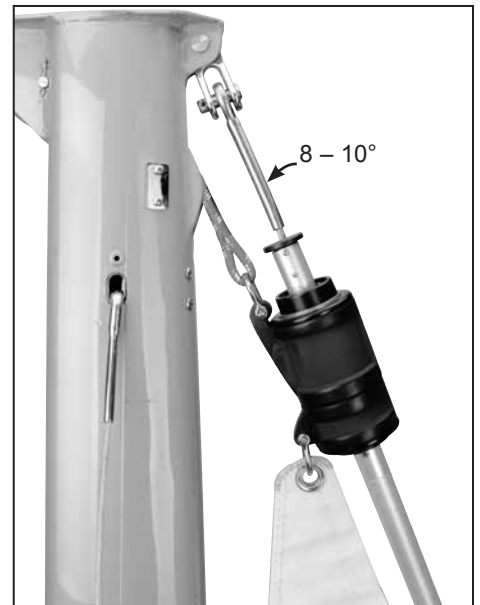

Halyard Deflector/Halyard Restrainer

To prevent wraps, jib halyard must pull slightly to rear. On most boats, halyard lead angle is acceptable if halyard swivel is raised to top of foil.

On some boats halyard sheaves are located too close to headstay and a halyard deflector or a halyard restrainer must be used.

Halyard restrainers should be used only when required by masthead geometry. Restrainers tend to limit sail luff length and may cause problems if not installed properly.

If your boat needs a halyard deflector, use Part No. 7301 or a halyard restrainer, use Part No. 944.

The restrainer should be mounted as high as possible on face of mast. Position restrainer so that foils will not hit it when under load.

The restrainer should deflect halyard as little as possible or you can experience difficulty in tensioning sail luff, and encounter friction when furling, possibly damaging the foils. To decrease deflection angles, shorten sail luff.

Tip: Boats used in charter service should have a halyard restrainer, regardless of masthead geometry.

Halyard Tension

The jib halyard should be firm, but not too tight.

Tip: The luff foil system supports sail along its length so halyard tension is used only to shape sails, not to support them. Use enough halyard tension to remove some wrinkles along luff of sail. Do not tension halyard enough to cause vertical wrinkles in luff of sail. Tension to adjust position of draft in sail to suit sailing conditions. Halyard should be firm but not tight. If in doubt, release halyard tension. To protect sail, ease halyard when boat is not in use.



Halyard deflector



Halyard restrainer

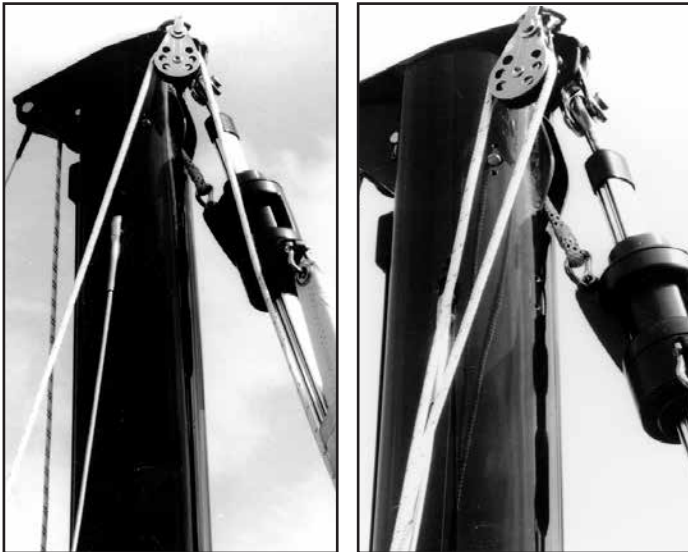

Spinnaker Halyards

Spinnaker halyards occasionally cause problems with furling.



WARNING! In severe cases, spinnaker halyards can jam furler, causing loss of control of boat. Make sure halyards are clear of top of foils and halyard swivel.

On many boats, it will not be possible to attach spinnaker halyard to bow pulpit, or it may be "sucked" into jib when furling.

On some boats, the spinnaker halyard lays across headstay and will catch on halyard swivel, foils, or jib halyard. To prevent problems, it might be necessary to install a masthead bail to move spinnaker halyard block forward and to one side.

Boats with external halyards might find it necessary to flip both ends of spinnaker halyard behind spreaders to prevent fouling with furling system.

Headstay Tension

A furling system will work best if headstay is tight.

A loose headstay is difficult to rotate and can cause unusual wear on foil joints.

To adjust headstay tension, first check to see if turnbuckle is below deck. If so, make adjustments up under the bow. If it is not belowdeck remove sail and follow instructions on page 26.

Tip: Before adjusting headstay tension, slack mainsheet and vang.

Backstay Adjusters

Backstay adjusters allow headstay tension to be varied to change sail shape to match conditions. They permit a very tight headstay to be eased when boat is not in use. For best performance, consider adding a backstay adjuster; either a block and tackle, a mechanical adjuster like those offered by Harken, or a hydraulic adjuster.

Remember to keep headstay tight for best performance when furling or reefing.

If your boat is fitted with an adjuster, be sure it is tensioned **before** the halyard is tensioned. If not, backstay adjuster may increase halyard tension and could damage the sail or furling system.

Racing boats often slack the headstay completely when sailing downwind. Check to be sure that foil does not jam against upper headstay terminal when backstay is released. To prevent this, it might be necessary to shorten foil slightly.





Raise Sails

- 1) Install prefeeder by securely tying end of line to a deck fitting or to toggle below furler so it is 610 mm (2') below feeder.
- 2) Shackle tack of sail to tack shackle. Install shackle so screw pin head is on same side as sun cover.
- 3) Secure genoa sheets to clew of sail.
- 4) Attach genoa halyard to halyard swivel.
- 5) Pass luff tape through prefeeder and feeder into foil groove.
- 6) Attach head of sail or pendant at head of sail to halyard swivel.
- 7) Hoist sail.

Tip: New sails are often stiff and can hang up on prefeeder during raising. Do not force sail when it hangs up—lower and remove twist. Sails "break in" with use and will become easier to raise.

Storm Sails

Most people will use one multipurpose genoa for all their sailing, but it is not good seamanship to go offshore without storm sails.

Heavy-air working jibs and storm sails may be used with your unit. These sails need to have luff tape added to allow them to be raised in headstay foils.

These sails will generally require pendants to ensure that halyard swivel is properly positioned at top of headstay. See page 29.

Remember that heavy-air working jibs and storm jibs may be reefed and furled like any other sail.

Furl and Reef

To furl or reef, ease the jib sheets and pull furling line.

In very light air, it might be necessary to place some tension on jib sheet to insure a tight furl.

In a breeze, you must **completely** luff sail by **totally** slacking jib sheets before furling.

The furling line should pull readily. The amount of force required is related to amount of wind, but unit should never require use of a winch to furl. If the sail will not furl, or if furling requires a great deal of effort, there is a problem with system. Consult the Troubleshooting Guide on page 35. Do not use a winch to force a system to turn. If you are certain that the system is operating properly, you may use a winch to make furling easier.

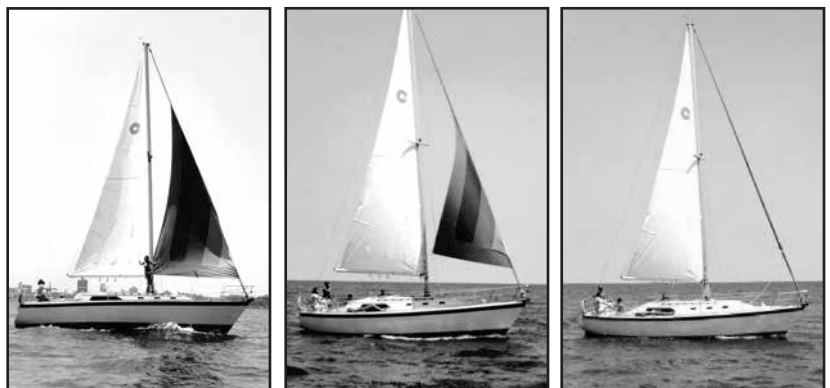

Reef

A sail can be partially furled before you resume sailing. This is known as reefing.

Many sailors find it helpful to place marks on foot of sail so they can reef to a variety of predetermined jib sizes. This allows marks to be placed on jib lead tracks or toe rail so lead block position can be changed to correspond to reefed jib.

Sails are generally reefed to balance boat and to reduce heeling moment. Sails are also reefed to improve visibility, to slow boat while sailing in congested areas, or while entering or leaving harbor.

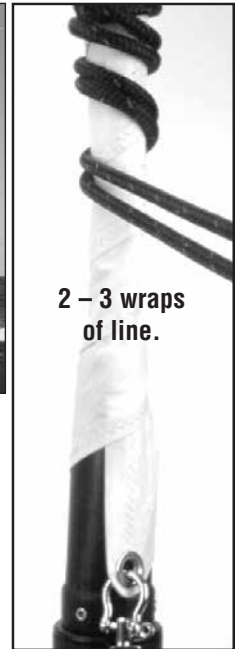

Secure Sail

When furling prior to leaving your boat in slip or on mooring, be sure you get a tight furl. Continue furling system until sheets wrap around rolled sail two (2) or three (3) times. Some people secure sail with shockcord or sail ties. Be sure to securely cleat furling line to a standard horn cleat.

Be sure that mooring lines are not placed across furling line where they can cause chafe.

Race conversion allows use of both grooves for sail changes and tacking genoas on deck for use of maximum luff length genoas.

Halyard Swivel Below Feeder

Use halyard to lift halyard swivel up, away from feeder. Loosen screw **one (1) revolution only**. Slide screw up and hold. Remove feeder carefully—bottom end first. **Don't lose the feeder overboard!** Lower swivel onto torque tube. Replace feeder.

Remove Feeder



Loosen screw **one (1) revolution only**.



Slide screw up and hold.

Halyard Swivel Off Furler

Serious racers might want to remove the halyard swivel.

1. Rig a secure, temporary headstay.
2. Determine location of turnbuckle.
3. Refer to pages 23 – 25 for procedure for loosening and disassembling turnbuckle so the halyard swivel can slide off foils and stay.

Note: It is not possible to remove halyard swivel on a unit with a Norseman/STA-LOK® or rod adapter stud unless you disassemble terminal stud. Make sure you use a new Norseman/STA-LOK wedge to reassemble Norseman/STA-LOK fitting.

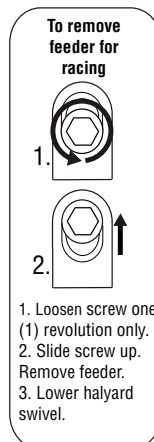

Carefully remove feeder—bottom end first. **Don't drop the feeder overboard!**

STA-LOK is a registered trademark of Sta-Lok Terminals, Ltd.

Clean and Lubricate

Keep unit clean. When you wash boat, flush unit with soap and fresh water. Occasionally lower sail and flush halyard swivel with soap and fresh water.

- 1) To clean drum bearings, squirt a mild detergent and water solution into the small gap between the plastic ball and the spool extension as shown at right. Spin drum and let soak. Follow with one (1) minute flushing with hose.
- 2) If a more thorough cleaning is required: Take all precautions to keep mast secure before disconnecting stay. Remove bridge assembly. Remove ball/spool assembly. Flip upside down and flush bearings as above, but through the line opening in the ball/guard.

Clean foils by washing with soap and water. A scrap of luff tape may be run up foil to scrub inside the grooves. Spray foils with McLube® conditioner and lubricant to reduce friction during sail changes.

McLube is a registered trademark of McGee Industries, Inc.



Clean halyard swivel bearings.

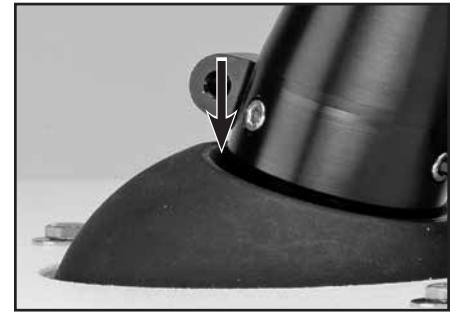

Clean drum bearings.



Remove bridge assembly.



Remove ball/spool assembly.



WARNING! Periodically inspect items listed below and others as necessary. Failure to inspect can cause an accident.

Inspect

- 1) Unit for signs of chafe, wear, or damage.
- 2) Turnbuckle below drum or inside torque tube for signs of loosening. Check headstay tension for signs of loosening.
- 3) Rigging components for signs of stress corrosion.
- 4) Norseman or STA-LOK® terminal or rod terminal for signs of loosening.
- 5) All screws on unit to be sure they have not loosened.
- 6) Foil to make sure it has not dropped into torque tube. Periodically inspect wire for signs of wear or unraveling.

Replace Line

Use small-diameter, high-strength line at forward end and have a rigger add a cover at the aft end where the line is handled. Forward diameter 5 mm (3/16"). Aft diameter 6 mm (1/4").

Storage – Mast Down

In areas where it freezes, do not store system where water can accumulate in foils. When water freezes it will rupture aluminum. Store foils under cover, with grooves facing down or on an angle so water will run out.

Storage/Transporting

Do not store or transport system with large extensions beyond mast. Remove masthead clevis pin and shift furler up so drum assembly can be strapped securely to mast. Some people remove drum assembly and halyard swivel for storage and transport.

After Storage or Transport

After storing or transporting unit, clean thoroughly including ball bearings. See instructions above.

Remove Furler From Boat

In order to prevent foils from locking against upper stay terminal when backstay is released, loosen torque tube screws and lower foil before loosening backstay.

STA-LOK is a registered trademark of Sta-Lok Terminals, Ltd.

Troubleshoot

Problem	Probable Cause	Solution
Sail will not furl or is difficult to furl.	Jib halyard is wrapping around headstay because angle between mast and halyard is too shallow.	See installation instructions regarding optimal halyard angle. It might be necessary to mount a halyard restrainer on front of mast to hold halyard to rear.
	Jib halyard is wrapping around the headstay because halyard swivel is too low.	See installation instructions regarding optimal halyard swivel height. A wire pendant might be needed at head of sail to raise halyard swivel to proper height.
	Jib halyard is too tight.	Ease jib halyard.
	Foils riding on turnbuckle.	Raise foils. See adjusting turnbuckle on page 23.
	Foils too high, binding on swage eye.	Lower foils until clear. See adjusting turnbuckle on page 23.
	Spare halyard is wrapping in sail as it furls.	Secure spare halyards away from furling headstay by flipping them behind spreaders
	Salt or dirt in bearings.	Flush bearings frequently with fresh water and a detergent solution.
	Furling line tangled in drum.	Overrides are best prevented by using a 7402 ratchet block as the last furling line lead to maintain proper drag on line while unfurling.
	Stop knot catching.	Make sure knot is a single overhand and is pushed up inside drum.
	Sail full of wind.	Luff completely before furling or reefing.
	Sail flogging too much.	Release a short length of sheet, pull some furling line and repeat.
	Jib sheets are not free.	Free jib sheets.
	Foil out of torque tube.	Reinstall foil in torque tube and tighten clamp screws.
	No wraps of furling line on drum.	Remove sheets. Rotate stay wrapping as much furling line on drum as possible.
	Furling line is charged in the wrong direction.	Make sure line is charged clockwise so that furling direction is counter-clockwise.
	Sail will not unfurl or will not unfurl completely.	Jib halyard is wrapping around headstay because angle between mast and halyard is too shallow.
Jib halyard is wrapping around the headstay because the halyard swivel is too low.		See installation instructions regarding optimal halyard angle.
Foils riding on turnbuckle.		Raise foils. See adjusting turnbuckle on page 23.
Foils too high, binding on swage eye.		Lower foils. See adjusting turnbuckle on page 23.
Jib halyard is too tight.		Ease jib halyard.
Spare halyard is wrapping in sail as it furls.		Secure spare halyards away from furling headstay by flipping them behind spreaders.
Salt or dirt in bearings.		Flush bearings with freshwater and detergent.
Furling line is not free.		Free furling line.
Sail will not furl completely.	Insufficient furling line on drum.	Remove sheets. Rotate stay, wrapping as much furling line on drum as possible.
	Too much line on drum.	Adjust amount of line on drum or change position of forward lead block to allow line to roll evenly on drum.
	Spare halyard catching in sail as it furls.	Move halyards away from furling headsail as above.
Headstay rotates in jerks or elliptically.	Insufficient tension on headstay.	Tighten headstay and/or backstay to eliminate sag in headstay.
Sail does not stay furled.	Sail not furled tightly on stay.	Maintain drag on sheets while furling.
	Furling line not secure.	Secure furling line.
Sail will not go up.	Luff tape will not go into groove.	Check luff tape for fraying.
		Check luff tape size.
	Sail catching at prefeeder.	Flake sail more loosely on deck.
	Dirt in groove.	Clean groove.
Sail will not raise completely or luff will not tension.	Halyard swivel is hitting endstop.	Luff of sail is too long and must be recut.
	Angle between halyard and mast is too sharp and halyard is pulling too much to the rear.	Halyard must be routed from a point higher on mast. This might require that any halyard turning blocks aloft be replaced or sail shortened.
Sail will not come down.	Halyard is wrapping on headstay.	Angle between headstay and halyard is too shallow and must be optimized per installation instructions.
	Halyard swivel off foil.	Sail luff too long or foil is too short or low and must be lengthened or raised.
Ultraviolet cover rolls up inside of sail.	Furling line is wrapped on drum in wrong direction.	Remove sail and sheets. Pull line to remove all furling line from drum. Turn stay to rewind line on drum in a clockwise direction. Suncover must be on the starboard side of sail. Make sure line is charged clockwise so that furling direction is counter-clockwise.

Delrin is a registered trademark of E. I. du Pont de Nemours and Company or its affiliates.
McLube is a registered trademark of McGee Industries, Inc.

Loctite is a trademark of Henkel AG & Company KGaA.
Torton is a registered trademark of Solvay Advanced Polymers.

Online product registration
www.harken.com/furlingwarranty

Warranty: www.harken.com/manuals
or call, write, email or fax Harken, Inc.,
Pewaukee, WI USA

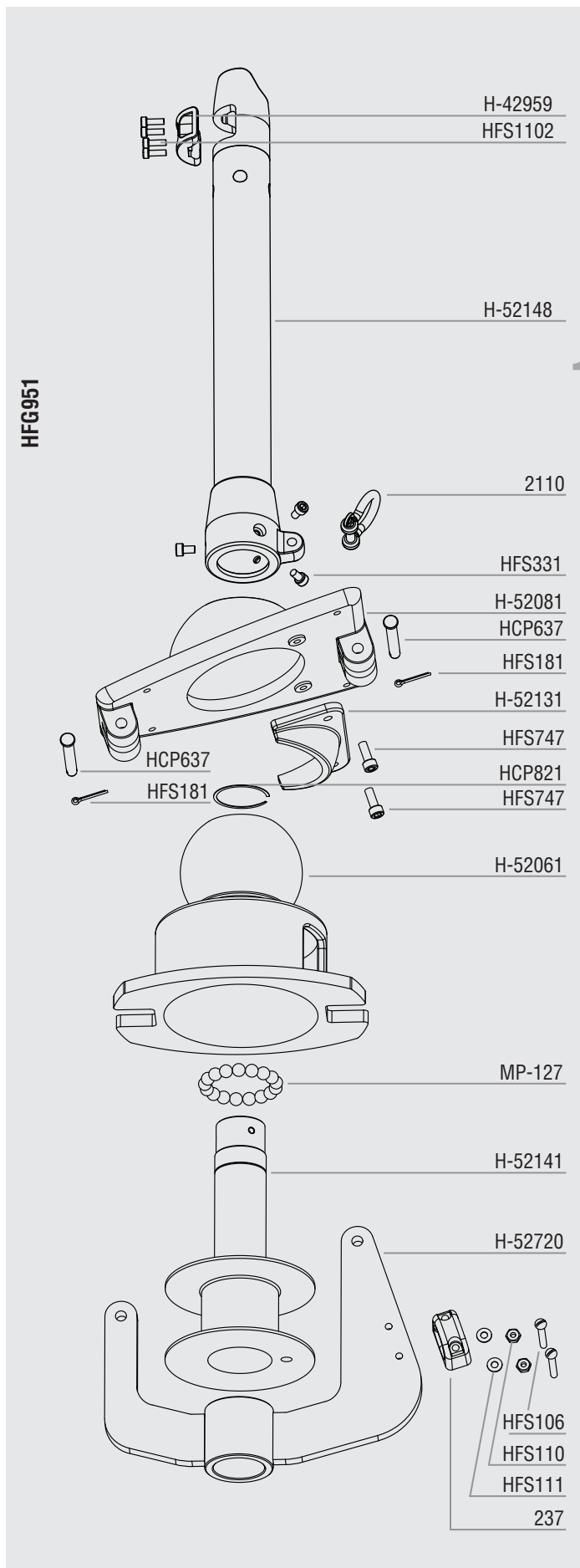

1

No.	Description	Order	Part No.
	Foil clamp	1	H-42959
	Socket head cap screw (M4 X 12 mm)	4	HFS1102
	Torque tube	1	H-52148
	Socket head cap screw (M5 X 8 mm)	3	HFS331
	Bow shackle 6 mm	1	2110
	Deck plate	1	H-52081
	Clevis pin (5/16" X 2.219")	2	HCP637
	Cotter pin (.094" X .750")	2	HFS181
	Keeper	1	H-52131
	Socket head cap screw (M6 X 16 mm)	2	HFS747
	Smalley retaining ring (VS-150-S02)	1	HCP821
	Ball/guard	1	H-52061
	Torlon® ball (3/8")	17	MP-127
	Spool	1	H-52141
	Bridge	1	H-52720
	Bullseye fairlead	1	237
	Slotted roundhead screw (10-32 X 1.500")	2	HFS106
	Flatwasher 10 (.032" X .203" X .438")	2	HFS111
	Hex nut 10-32	2	HFS110

Torlon is a registered trademark of Solvay Advanced Polymers.

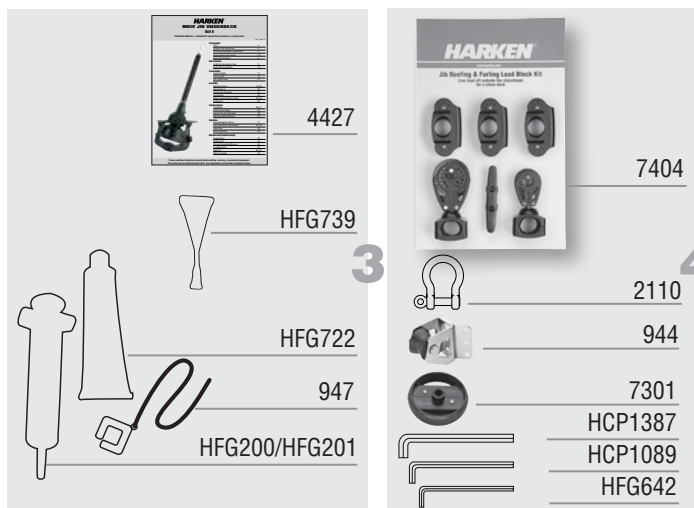
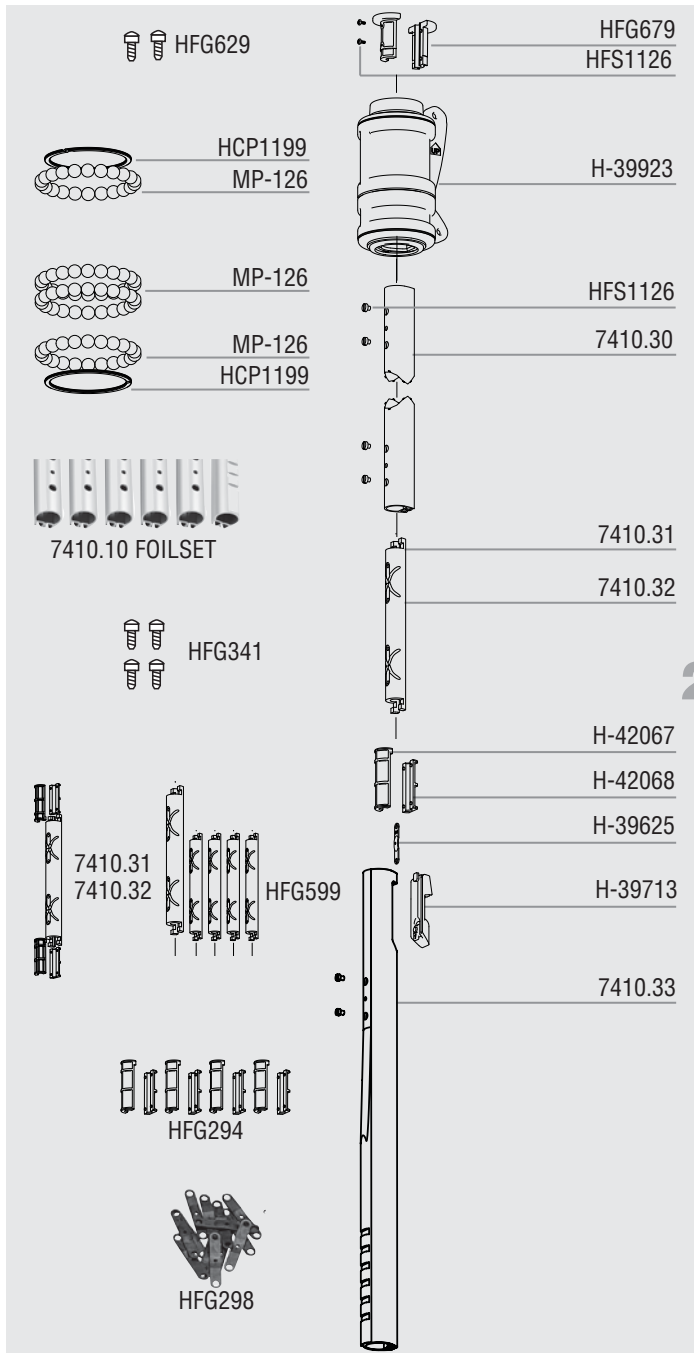

Description	Order	Part No.
2 Trim cap set w/o screws	1	HFG679
Trim cap screw set	1	HFG629
Trim cap screw	2	HFS1126
Halyard swivel w/o shackles	1	H-39923
Torlon® ball bearings	96	HSB17
Clip/smallley ring	2	HCP1199
Foil set	1	7410.10 FOILSET
Foil (2.13 m/7' luff)	5	7410.30
Foil (610 mm/2') bottom	1	7410.33
Foil screw set	1	HFG341
Foil screw	26	HFS1105
Connector set w/o bushings	1	HFG599
Connector (178 mm/7")	4	—
Connector bottom (273 mm/10.75")	1	—
Connector bushing set	1	HFG294
Connector bushing (curved/longer)	10	H-42067
Connector bushing (flat/shorter)	10	H-42068
Connector w/bushings	1	7410.31
Connector (165 mm/6.5")	1	—
Connector bushing (curved/longer)	2	—
Connector bushing (flat/shorter)	2	—
Connector w/bushings bottom	1	7410.32
Connector bottom (254 mm/10")	1	—
Connector bushing (curved/longer)	2	—
Connector bushing (flat/shorter)	2	—
Connector wedge set	1	HFG298
Connector wedge	12	H-39625
Feeder set	1	H-39713
Feeder	1	H-37272B
Feeder screw	1	HFS1128
Tab	1	H-37282A

Torlon is a registered trademark of Solvay Advanced Polymers.

Description	Order	Part No.
3 Instruction manual	1	4416
Prefeeder	1	947
Red Loctite® adhesive	2	HFG739
5200 adhesive set	1	HFG725
5200 marine adhesive sealant	1	HFG722
Injector	1	HFG201
7 mm single braid polyester (55'/16.7 m)	1	HFG594

Description	Order	Part No.
4 Lead block kit	1	7404
29 mm outboard lead assembly	3	7403
57 mm Carbo ratchet assembly	1	7402
40 mm Carbo assembly	1	7401
Horn cleat	1	HCP168
Bow shackle (6 mm)	3	2110
Halyard restrainer	1	944
Sheave/ss inner race only	1	944ASSY
Clevis pin (18 - 8 mm/ 1/4" x .9")	1	HFG467
Bracket — small	1	HCP393
Cotter pin (18 - 8 mm/ 1/16" x 1/2")	1	HFS118
Halyard deflector	1	7301
Hex keys		
2.5 mm	1	HCP1387
3 mm	1	HCP1089
5 mm	1	HFG642

Loctite is a trademark of Henkel AG & Company KGaA.

Hole saw size recommendations. Read before drilling.

110 mm (4 1/4")—Requires some beveling of bottom edge of deck hole to provide a good fit. Alternatively, a smaller hole can be used to fashion a socket in deck to conform to ball shape. This may improve appearance and reduce amount of water that enters.

115 mm (4 1/2")—Use if no beveling to underside of deck is desired.

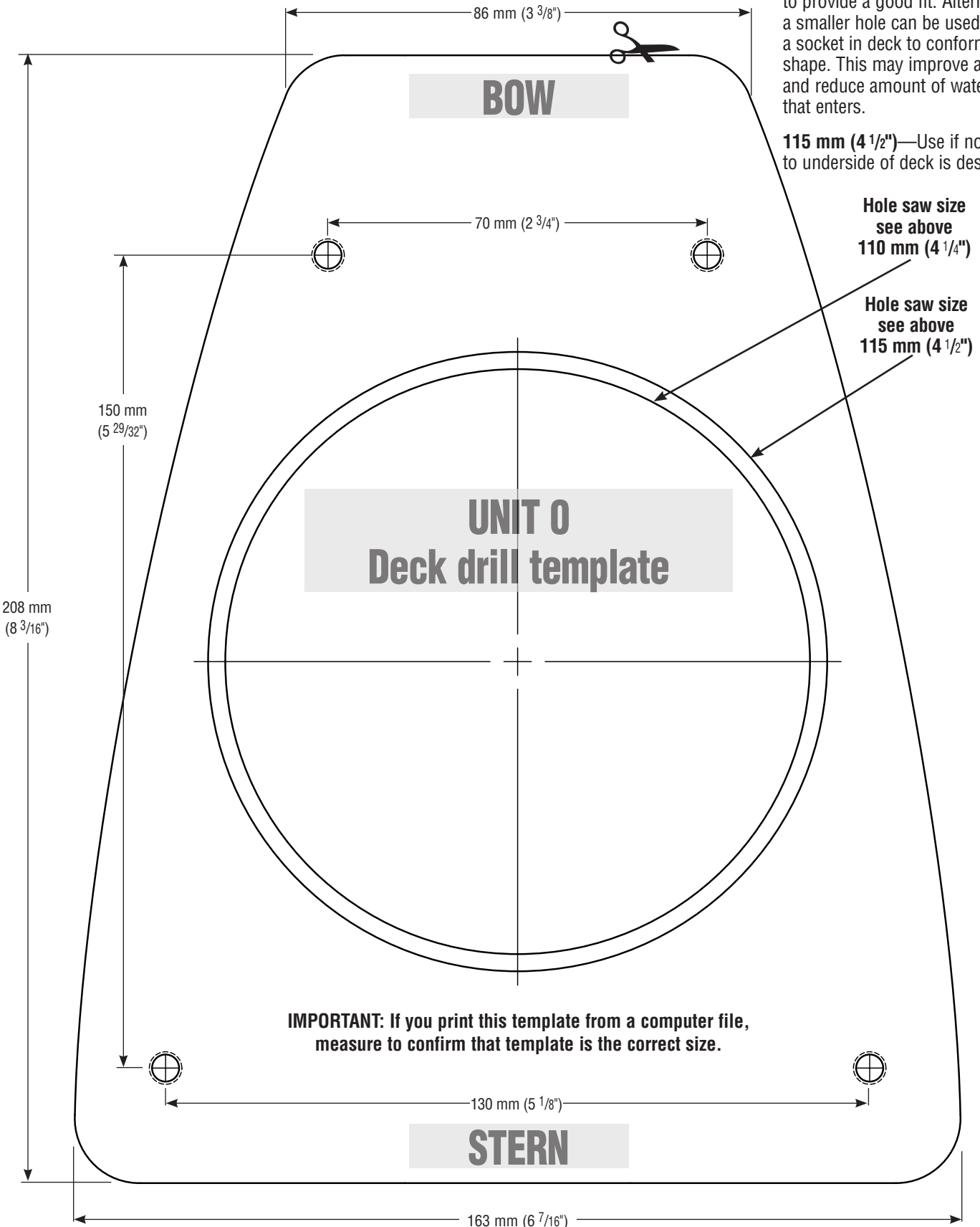

IMPORTANT: If you print this template from a computer file, measure to confirm that template is the correct size.

HARKEN®

Corporate Headquarters

N15W24983 Bluemound Rd, Pewaukee, WI 53072 USA
Telephone: (262) 691-3320 • Fax: (262) 701-5780
Web: www.harken.com • Online Catalog: www.harkenstore.com
Email: harken@harken.com

Harken Australia Pty, Ltd.

1B Green Street, Brookvale, N.S.W. 2100, Australia
Telephone: (61) 2-8978-8666 • Fax: (61) 2-8978-8667
Web: harken.com.au • Email: info@harken.com.au

Harken France

ZA Port des Minimes, BP 3064, 17032 La Rochelle Cedex 1, France
Telephone: (33) 05.46.44.51.20 • Fax: (33) 05.46.44.25.70
Web: harken.fr • Email: info@harken.fr

Harken Italy S.p.A.

Via Marco Biagi, 14, 22070 Limido Comasco (CO) Italy
Telephone: (39) 031.3523511 • Fax: (39) 031.3520031
Web: harken.it • Email: info@harken.it

Harken New Zealand, Ltd.

30-36 Fanshawe Street, P.O. Box 1951, Auckland 1001, New Zealand
Telephone: (64) 9-303-3744 • Fax: (64) 9-307-7987
Web: harken.co.nz • Email: harken@harken.co.nz

Harken Polska SP ZOO

ul. Rydygiera 8, budynek 3A, lokal 101, I piętro, 01-793 Warszawa, Poland
Tel: +48 22 561 93 93 • Fax: +48 22 839 22 75
Web: harken.pl • Email: polska@harken.pl

Harken Sweden AB

Main Office and Harken Brandstore: Västmannagatan 81B
SE-113 26 Stockholm Sweden
Telephone: (46) 0303 61875 • Fax: (46) 0303 61876
Mailing address: Harken Sweden AB, Box 64, SE -440 30 Marstrand
Web: harken.se • Email: harken@harken.se

Harken UK, Ltd.

Bearing House, Ampress Lane, Lymington, Hampshire S041 8LW, England
Telephone: (44) 01590-689122 • Fax: (44) 01590-610274
Web: harken.co.uk • Email: enquiries@harken.co.uk

Please visit: <http://www.harken.com/locator.aspx>
to locate Harken dealers and distributors

