

NOTE: PUMP REQUIRES FOUR M8 FASTENERS FOR MOUNTING

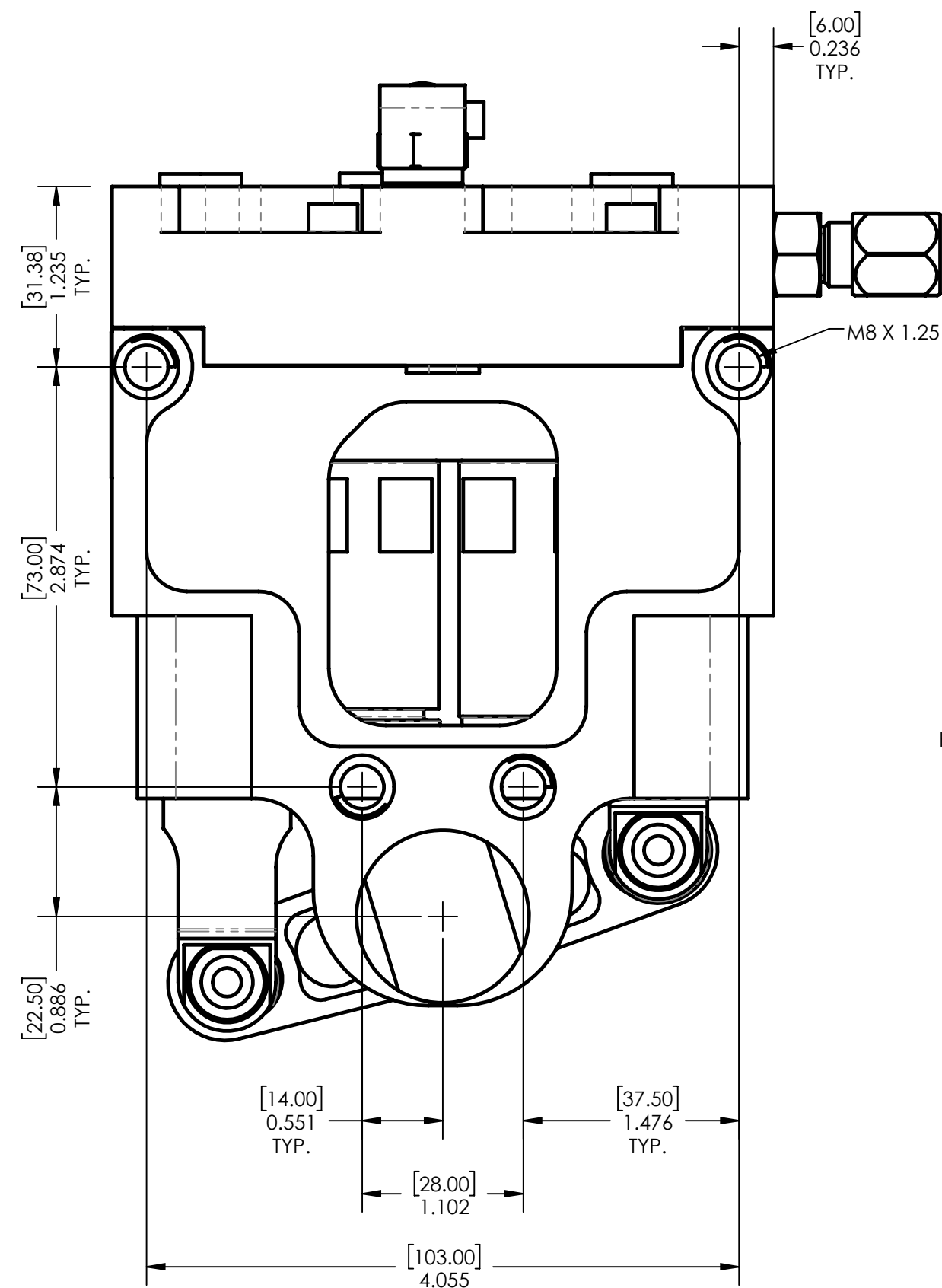

RANGE OF PUMP HANDLE ANGLES
3.5°, 2°, 0°

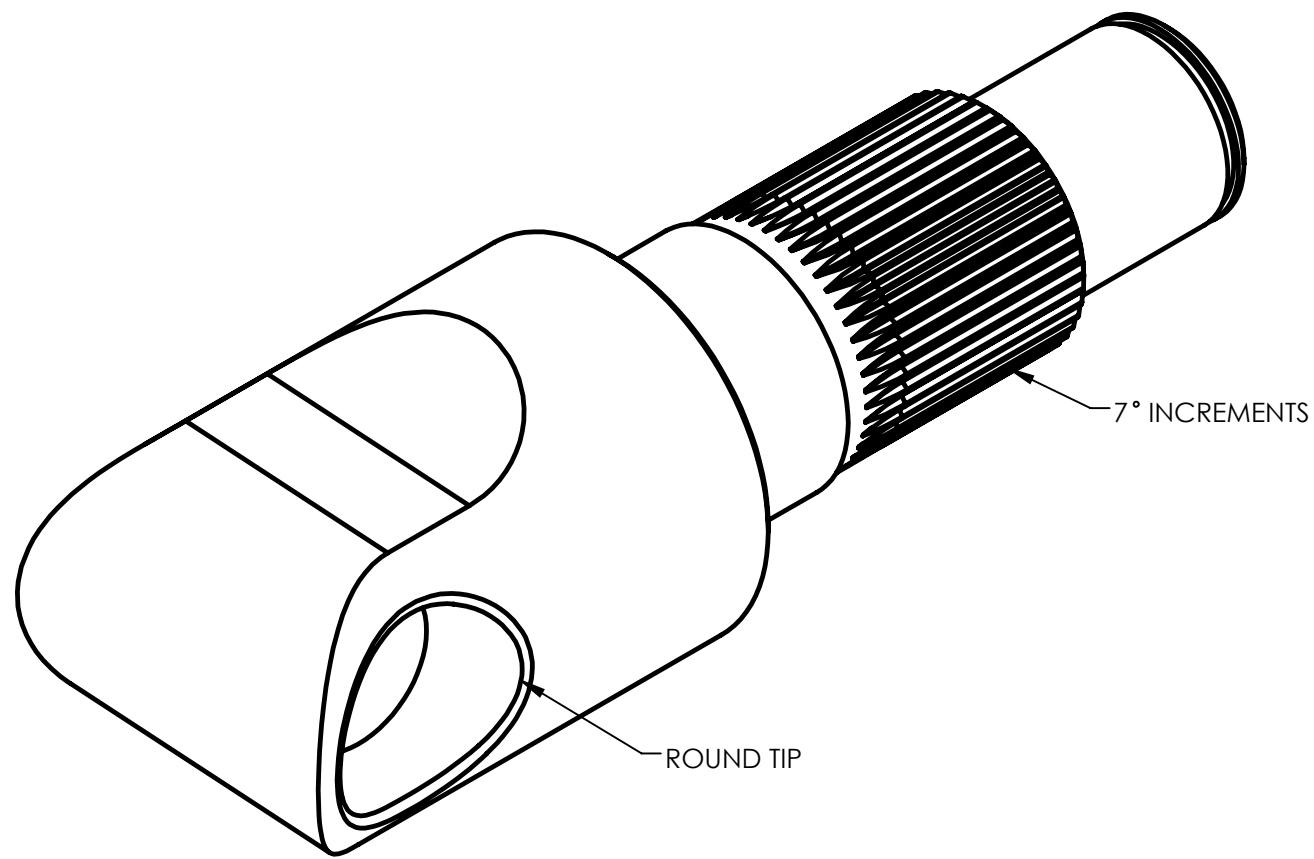
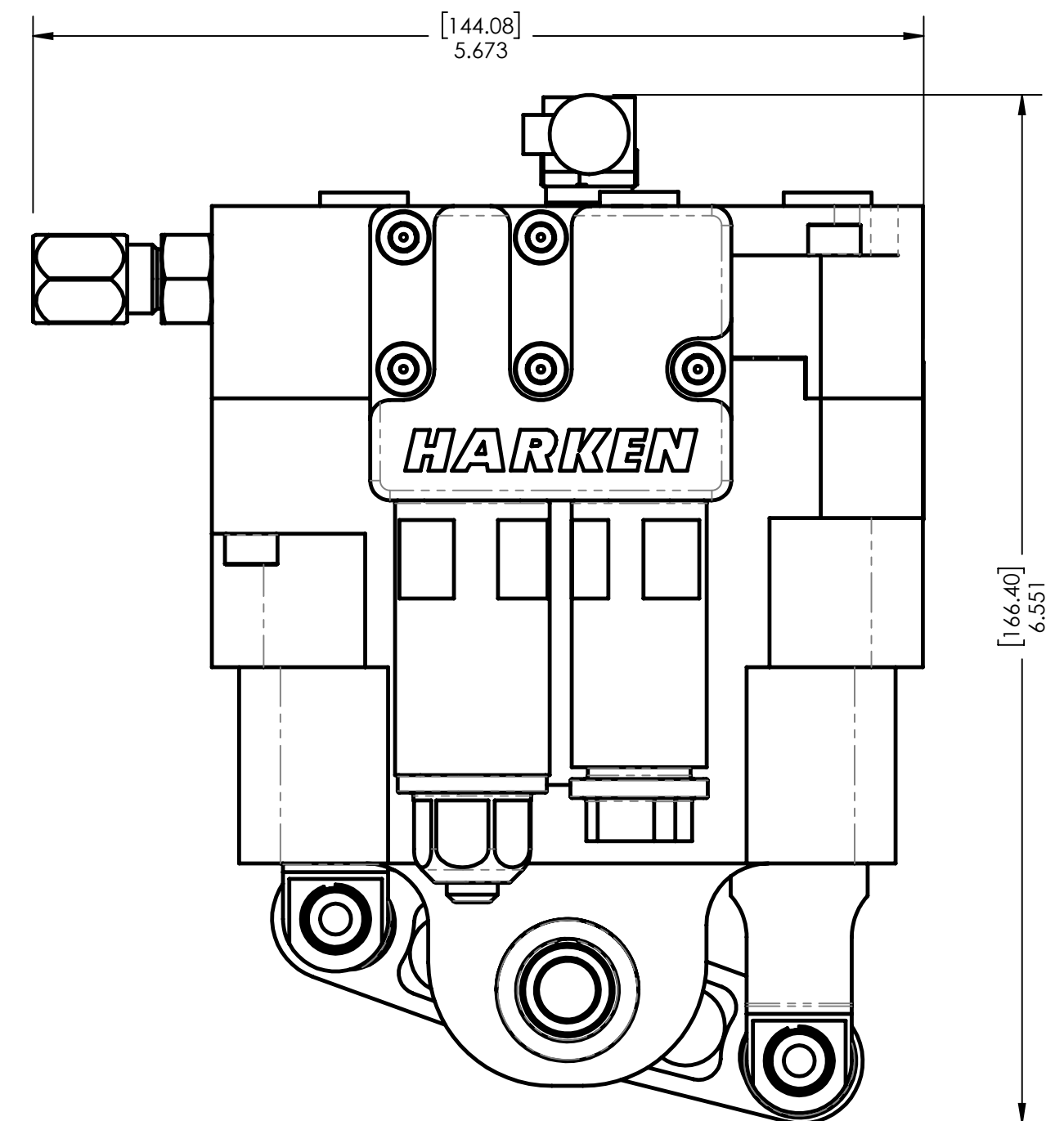
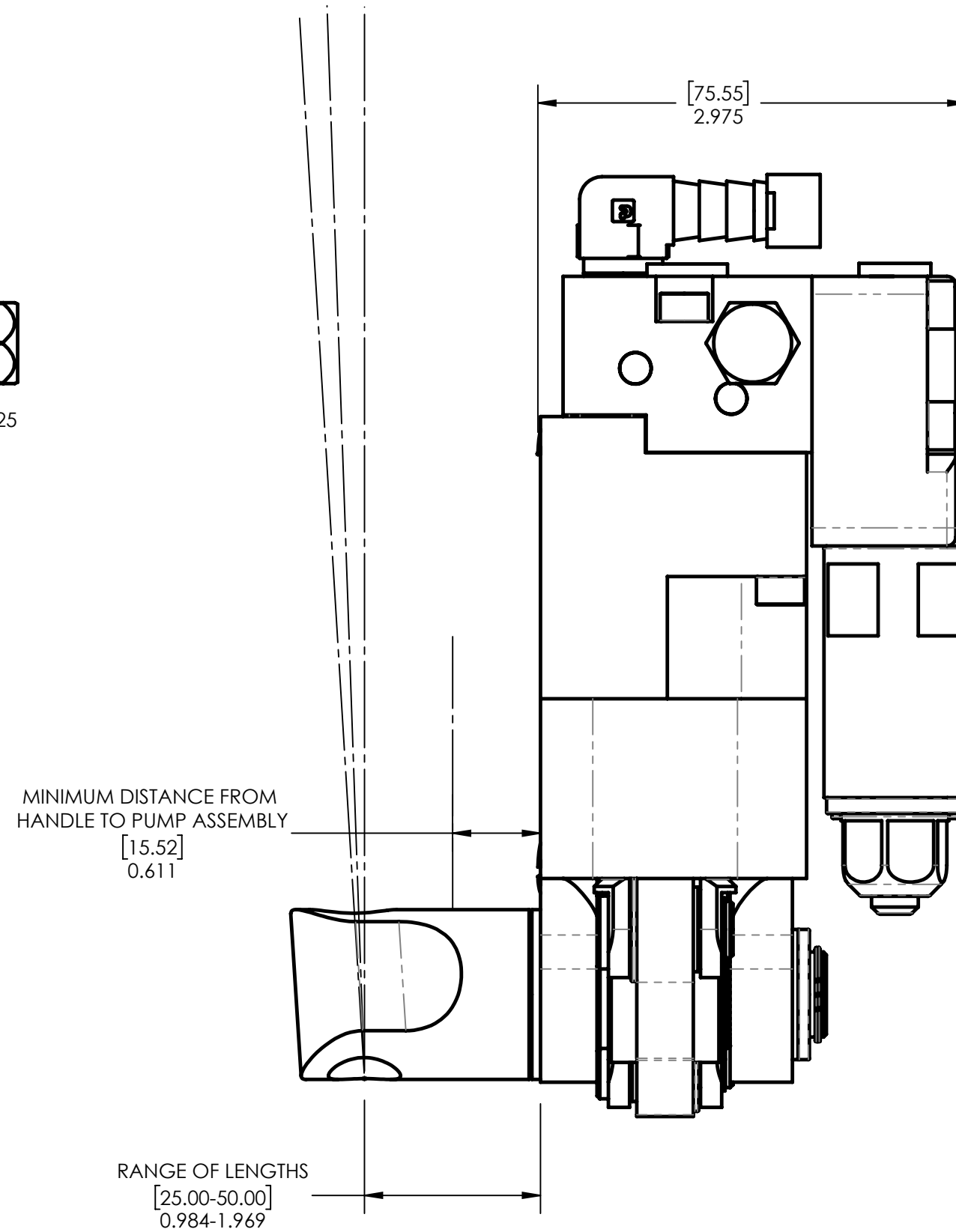

HARKEN
INCORPORATED
N15 W24983 Bluemound Road
Pewaukee, Wisconsin 53072
Tel: 262-691-3320
Fax: 262-691-3807
www.harken.com

DIMENSIONS IN OVALS ARE KEY PRODUCT CHARACTERISTICS
UNLESS OTHERWISE SPECIFIED:
- DIMENSIONS IN INCHES
- ALL DIMENSIONS PRIOR TO FINISHING
- REMOVE ALL BURRS AND BREAK SHARP EDGES WITH 0.010 MAX RADIUS OR CHAMFER

TOLERANCES UNLESS OTHERWISE SPECIFIED:
DECIMAL: ± - RADIUS: ± -
HOLE DIA: ± - CHAMFER: ± -
ANGULAR: ± - SURFACE FINISH: ✓

PUMP ASSY
TWO-SPEED MANUAL PUMP

MATERIAL: VARIOUS
FINISH: -

© The designs, constructions, arrangements, disclosures and devices illustrated in presentations bearing this note are the property of Harken, Inc. Pewaukee, WI and are submitted in confidence with the understanding that such material shall not be utilized in any way by any party without prior written consent from Harken, Inc.

DRAWING NUMBER	HYPM2	REV.	4
PART #	HYPM2	SHEET NUMBER:	2/2
DRAWN BY:	GSW	SCALE:	1:1
ENG. APR:	CJL	DATE:	4/26/2011
MFG. APR:		DATE:	8/12/2011