

Installation and Maintenance Manual

MRW-A

Powered Radial Winch **35.2 ST EL**

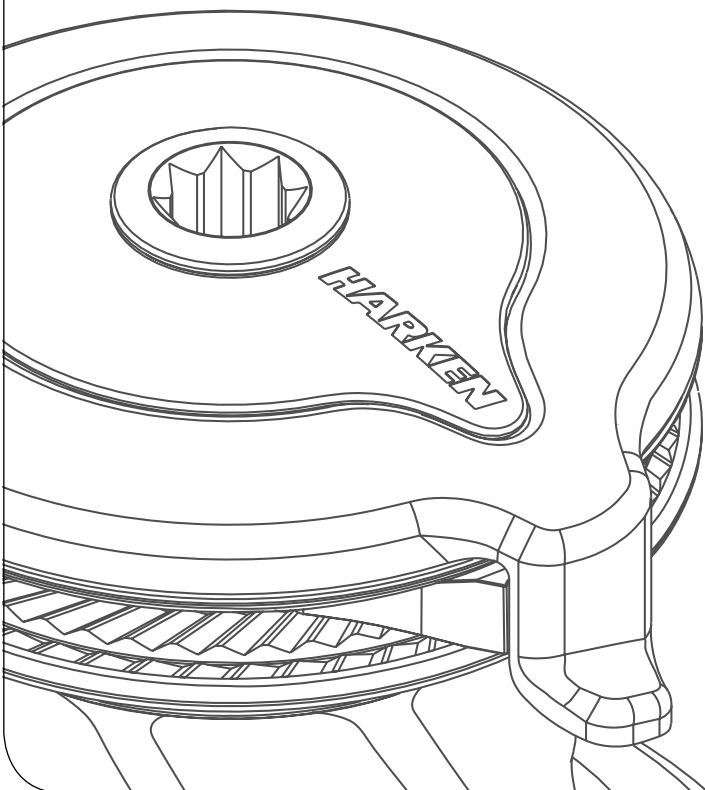

HARKEN[®]

Introduction	3
Technical characteristics	3
<i>Performance data</i>	3
<i>Weight</i>	4
<i>Maximum working load</i>	4
Outline	5
Installation	6
<i>Procedure 1</i>	7
<i>Procedure 2</i>	8
<i>Winch installation procedure</i>	10
<i>Positioning the self-tailing arm</i>	11
Motor installation procedure	11
<i>Electric equipment</i>	12
Maintenance	14
<i>Washing</i>	14
<i>Maintenance table</i>	14
<i>Disassembly procedure</i>	14
<i>Exploded view with maintenance products</i>	18
<i>Assembly</i>	19
Harken® limited worldwide warranty	20
Ordering spare parts	20
Exploded view	21
<i>Radial Winch 35.2 STA, STC, STCW</i>	21
Parts List	23
<i>Radial Winch 35.2 STA</i>	23
<i>Radial Winch 35.2 STC</i>	24
<i>Radial Winch 35.2 STCW</i>	25
Exploded view	26
<i>Radial Winch 35.2 STBBB, STCCC</i>	26
Parts List	28
<i>Radial Winch 35.2 STBBB</i>	28
<i>Radial Winch 35.2 STCCC</i>	29
Exploded view	30
<i>Horizontal electric motor 12V/24V</i>	30
Parts List	30
<i>Horizontal electric motor 12V/24V</i>	30

Introduction

This manual gives technical information on winch installation and maintenance, including disassembling and reassembling.

This information is DESTINED EXCLUSIVELY for specialised personnel or expert users.

Installation, disassembling and reassembling of the winch by personnel who are not experts may cause serious damage to users and those in the vicinity of the winch.

Harken® accepts no responsibility for defective installation or reassembly of its winches.

In case of doubt the Harken® Tech Service is at your disposal at techservice@harken.it

This Manual is available only in English. If you do not fully understand the English language, do not carry out the operations described in this Manual.

NOTICE

To use and understand this manual, user must refer to other documents, available on web site www.harken.com and listed below:

- The Dual Function Control Box user manual, for the use of the Dual Function Control Box.
- The Dual Function Control Box installation manual, for all details, informations, wiring schemes and warnings about its installation

Technical characteristics

	Power ratio	Gear ratio
1st speed	13,50 : 1	2,13 : 1
2nd speed	35,90 : 1	5,65 : 1

The theoretical power ratio does not take friction into account.

Performance data

Winch 35.2 ST EL (electric)

	horizontal motor			
	12 V (700 W)		24 V (900 W)	
	1st speed	2nd speed	1st speed	2nd speed
line speed (m/min)**	23,2	8,8	29,2	11
max load (Kg)	260	650	260	650

***Line speed is measured with no load*

		motor nominal power (W)		current absorption at winch MWL (A)	
		12 V	24 V	12 V	24 V
winch 35.2 ST EL	horizontal	700	900	170	90

Weight

	ST A EH	ST C/CW EH	ST BBB EH	ST CCC EH
weight (Kg)	13,3	14,5	15,2	15,2

Versions:

A = drum in anodised aluminium

C = drum in chrome bronze

CW = chrome/white

BBB = all bronze

CCC = all-chrome bronze

EH = horizontal electric winch

Maximum working load



WARNING!

The maximum working load (MWL) for the 35.2 ST Radial Winch is 650 Kg (1433 lb).

Subjecting the winch to loads above the maximum working load can cause the winch to fail or pull off the deck suddenly and unexpectedly during high loads causing severe injury or death.

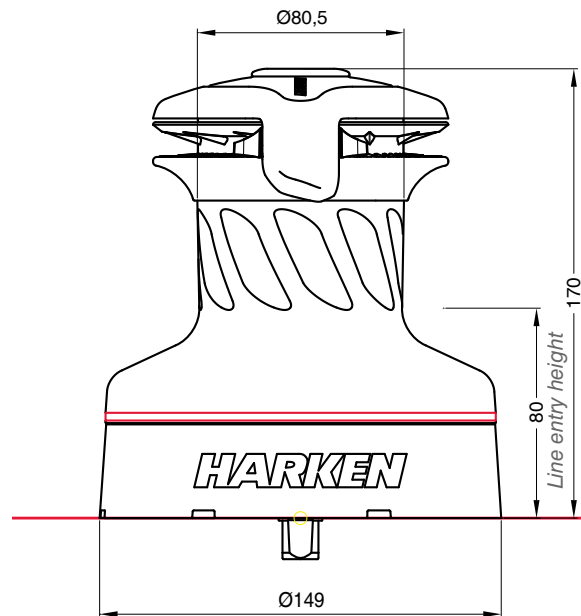
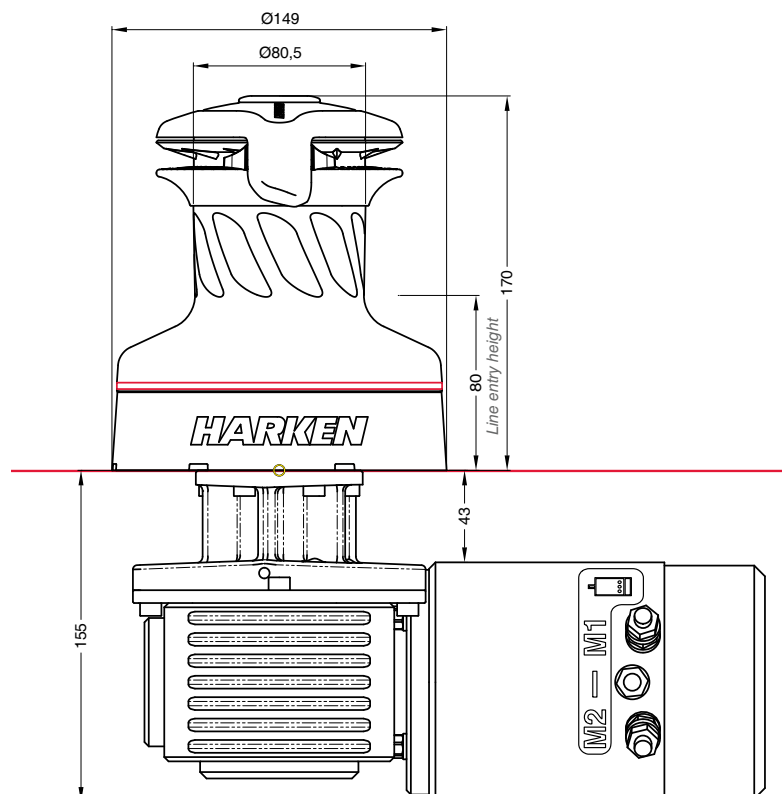
Outline*Winch 35.2 ST EL**Horizontal electric motor (12 V / 24 V)*

Installation

The winch must be installed on a flat area of the deck, reinforced if necessary to bear a load equal to at least twice the maximum working load of the winch.

It is the installer's responsibility to carry out all structural tests needed to ensure that the deck can bear the load.

Harken® does not supply the screws needed to install the winch since these may vary depending on the deck on which it is to be installed.

It is the installer's responsibility to choose the correct screws taking account of the loads they will have to bear.

Harken® assumes no responsibility for incorrect installation of its winches or for an incorrect choice of mounting screws.



DANGER!

Incorrect installation of the winch may cause severe injury or death. Consult the yard that built the boat in the case of doubt over the correct positioning of the winch.



WARNING!

Failure to use the correct number and type of mounting fasteners or failure to ensure the correct deck strength can result in the winch pulling off the deck suddenly and unexpectedly during high loads causing severe injury or death.



WARNING!

Verify the entry angle of the sheet. This must be 8° with tolerance of $\pm 2^\circ$, to avoid sheet overrides and damaging the winch or making the winch inoperable leading to loss of control of the boat which can lead to severe injury or death.

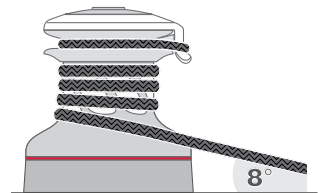

WARNING!

Mount the winch on the deck so that the drive gear is positioned where the sheet enters the winch drum. Incorrect position of drive gear can weaken winch leading to failure which can cause an accident leading to severe injury or death.

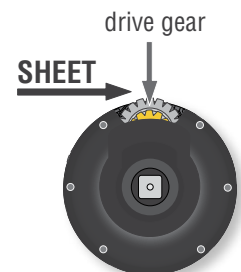

NOTICE

For winch STA, STC and STCW versions only
You can find the icon ▲ on the skirt to identify the drive gear position.



After correctly positioning the final drive gear with respect to the load, check that the motor, gearing, electrical wiring and/or hydraulic pipes can be housed below decks. To help find the optimal compromise, remember that, to make the installation of the motor easier, it can be coupled to the winch in different positions.

Once you have decided the correct mounting position for the winch on the deck and checked the space available below deck, proceed with the installation.

The winch can be installed following one of the two procedures below (Procedure 1 or Procedure 2):

Procedure 1

To install the winch, remove the drum and use Socket Head (SH) bolts.

Tools needed:  One medium flat-bladed screwdriver

To identify the various parts, refer to the exploded view at the end of this Manual.

 Torque to apply when assembling



1. Pull out the disconnect rod n°30



2. Unscrew the central screw ( 2Nm/18 in-lb)



3. Slide off the assy socket n°28 and the cover n°29.

Pay attention to the o-ring in the socket.



4. Unscrew the three screws n°27 ( 4Nm/35 in-lb)



5. Remove the self-tailing arm n°26 by rotating and lifting it.



6. Lift off the drum n°22

Install the winch on the deck in the position you have chosen, keeping in mind the limits described on page 6 and using socket head (SH) bolts.

Procedure 2 (not pertinent for ST BBB/CCC versions)

To install the winch, remove the winch skirt and use hexagonal headed (HH) bolts.

Tools needed:  One medium flat-bladed screwdriver

To identify the various parts, refer to the exploded view at the end of this Manual.

See (paragraph on installation) the limits described on page 6 and using socket head (SH) bolts.

 Torque to apply when assembling



1. Remove the skirt n°2 with the help of the screwdriver placed as shown by the symbol 



2. Take off the base n°2



3. Position the 5 M6 hexagonal headed bolts in their holes



4. Reposition the skirt n°2 in its housing



5. Press down the skirt to position it correctly

NOTICE

Make sure the skirt is correctly clipped on to the base of the winch.

Install the winch on the deck in the position you have chosen, keeping in mind the limits described on page 6 and using hexagonal headed bolts.

Winch installation procedure

Carry out Procedure 1 or Procedure 2, then install the winch on the deck in the chosen position.

NOTICE

Before drilling the deck, check the space available below deck for the flange and the motor

A. Position the base of the winch on the deck and mark the position of the holes or use the drilling cut-out template at the point where you have decided to place the winch.

Below is a reduced scale diagram.

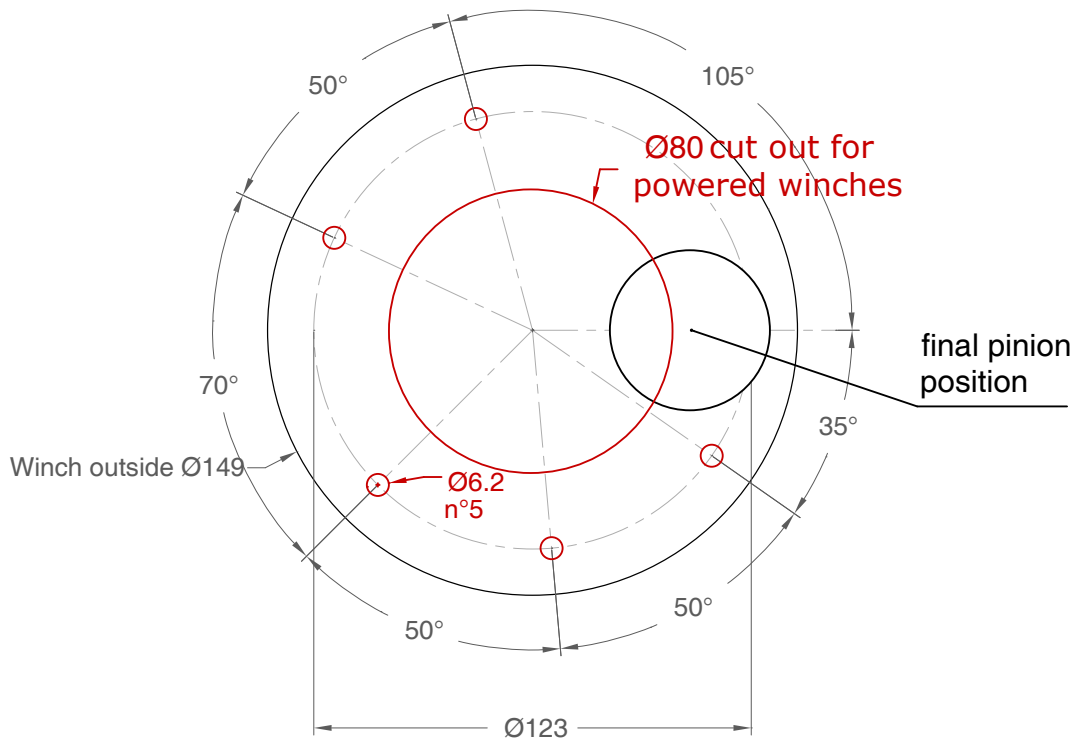

The drilling cut out template is available on the Harken® website, www.harken.com

B. Remove the winch and drill the five 6.2 mm and a 80 mm diameter holes.

C. Bolt the base of the winch to the deck using five M6 bolts (not supplied by Harken®) as described at Procedure 1 or Procedure 2, correctly chosen for the thickness and type of the boat deck. Consult the yard that built the boat in case of doubt.



WARNING!

To install the winch on the deck, use only bolts in A4 stainless steel (DIN 267 part11). Bolts made of other materials may not have sufficient strength or may corrode which can result in winch pulling off deck suddenly and unexpectedly during high loads causing severe injury or death.

NOTICE

To mount winches on the deck, do not use countersunk bolts.

D. Fill the mounting holes with a suitable marine sealant.

E. Remove the excess adhesive/sealant from the holes and base drainage channels

F. Reassemble the winch following the steps in **Procedure 1** or **Procedure 2** in the reverse order, and apply the products indicated in the section on maintenance.

NOTICE

Before closing the winch, make sure the holes and drainage channels in the base of the winch are not obstructed.

Positioning the self-tailing arm

Position the self-tailing arm so that the line leaving the winch is led into the cockpit.

Motor installation procedure**WARNING!**

Make sure that the electric power is switched off before installing or carrying out maintenance on the winch.

Once you have installed the winch on the deck, proceed with motor installation. The motor can be coupled to the winch in different positions. Check the space available below deck and choose the suitable position.

Tools needed

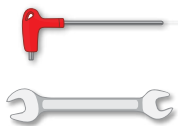

A number five hex key

A number six hex key (only for vertical electric motor)

A number ten hex key (only for hydraulic motor)

Two number thirteen wrenches



1. Position the flange (see Page 12)



2. Tighten six M6 precote coated screws
(8 Nm/ 71 in-lb)



3. Position the reduction gear and motor



4. Tighten the two screws (8 Nm/ 71 in-lb).
Be sure to align the flange.

NOTICE

Before positioning the flange, check to make sure that seals (the first one is above the flange and the second one is under the flange) are seated correctly.



After winch is assembled and before sailing, test the powered winch functioning: insert the lock-in winch handle in the handle socket and check that the disconnect rod must disconnect gearbox.

Electric equipment

To guarantee greater efficiency in terms of safety and long life, for every winch model is mandatory to install the Dual Function Control Box.

To fasten the Dual Function Control Box containing solenoids to bulkhead or wall, for all installation details and for all electric wiring schemes, refer to the Dual Function Control Box manual.



WARNING!

Before installing and using the device, read carefully the Dual Function Control Box manual available on web site www.harken.com

Refer to the following chart for wire size:

Total distance between winch and battery

Winch size	Current voltage	Under 16.4 ft AWG	Under 5 m mm ²	16.4 - 32.8 ft AWG	5 m - 10 m mm ²	32.8 - 49.2 ft AWG	10 m - 15 m mm ²	49.2 - 65.6 ft AGW	15m - 20 m mm ²
35.2	12 V	2	32	0	50	00	70	000	95
35.2	24 V	5	16	3	25	2	35	0	50

Refer to the following chart for HCP model:

Winch size	Current voltage	HCP model	Ampere rating
35.2	12 V	HCP1717	80A
35.2	24 V	HCP1717	80A

NOTICE

To connect motor, attach cable terminals to clamps between nut and lock nut. Hold nut in contact with motor using a spanner and tighten other nut with second spanner. Take special care not to turn the central spindles. These instructions apply when assembling and disassembling. We recommend using a torque wrench so as to obtain a torque equal to and no greater than 10 Nm (88 in-lb).

**NOTICE**

Note that correct electrical contact sequence is:
Nut – Cable Terminal – Self-Locking Washer – Lock Nut



Maintenance

Washing

Winches must be washed frequently with fresh water, and in any case after each use.

Do not allow teak cleaning products or other cleaners containing caustic solutions to come into contact with winches and especially anodised, chrome plated or plastic parts.

Do not use solvents, polishes or abrasive pastes on the logos or stickers on the winches.

Do not use polishes or abrasive pastes on anodised, chromed plated or plastics surfaces.

Make sure that the holes and drainage channels in the base of the winch are not obstructed so that water does not collect.

Maintenance table

Winches must be visually inspected at the beginning and end of every season of sailing or racing. In addition they must be completely overhauled, cleaned and lubricated at least every 12 months. After an inspection, replace worn or damaged components. Do not replace or modify any part of the winch with a part that is not original.



WARNING!

Periodic maintenance must be carried out regularly. Lack of adequate maintenance shortens the life of the winch, can cause serious injury and also invalidate the winch warranty. Installation and maintenance of winches must be carried out exclusively by specialized personnel.







WARNING!

Make sure that the power is switched off before installing or carrying out maintenance on the winch.

In case of doubt contact Harken® Tech Service at techservice@harken.it

Disassembly procedure

Tools needed:

-  One medium flat-bladed screwdriver
-  A number five hex key
-  Brush
-  Rags

To identify the various parts refer to the exploded view at the end of this Manual.

 Torque to be applied in assembly phase

Carry out **Procedure 1** as shown in the paragraph on winch installation and then do the following:



6. Completely unscrew the three screws n° 27 and remove the stripper arm support n°21



7. Slide out the central shaft n°19



8. Unscrew the 6 hex screws n°16
($\approx 20\text{Nm}/177\text{ in-lb}$)



9. Remove the assy housing n°15
Important: washer n°12 may remain inside the drum support!



10. Remove the washer n°12



11. Remove the gear n°7



12. Remove the pawls carrier n°4



13. Remove the gear n°3



14. Remove the gear n°14



15. Remove the gear n°10



16. Remove the pawls carrier n°11



18. Remove the washer n°9

If it is necessary to replace any jaws of the winch, proceed as follows:



I. Unscrew the 4 screws n°25
($\approx 4\text{Nm}/35\text{ in-lb}$)



II. Remove the jaws n°24

Once the winch is completely disassembled, clean the parts with a degreasing that does not leave residues, proper to clean metal components; rinse plastic parts in fresh water. Once you have done this, dry the parts with cloths that do not leave residue.

Inspect gears, bearings, pins and pawls for any signs of wear or corrosion.

Carefully check the teeth of gears and ring gears to make sure there are no traces of wear.

Check the roller bearings and check there are no breaks in the bearing cages.

Replace worn or damaged components.

Carry out maintenance on components using the products listed below.

For more information on which products to use where, refer to the exploded diagram below.

Use a brush to lightly lubricate all gears, gear pins, teeth and all moving parts with grease.

Lightly lubricate the pawls and springs with oil. Do not use grease on the pawls!

Exploded view with maintenance products

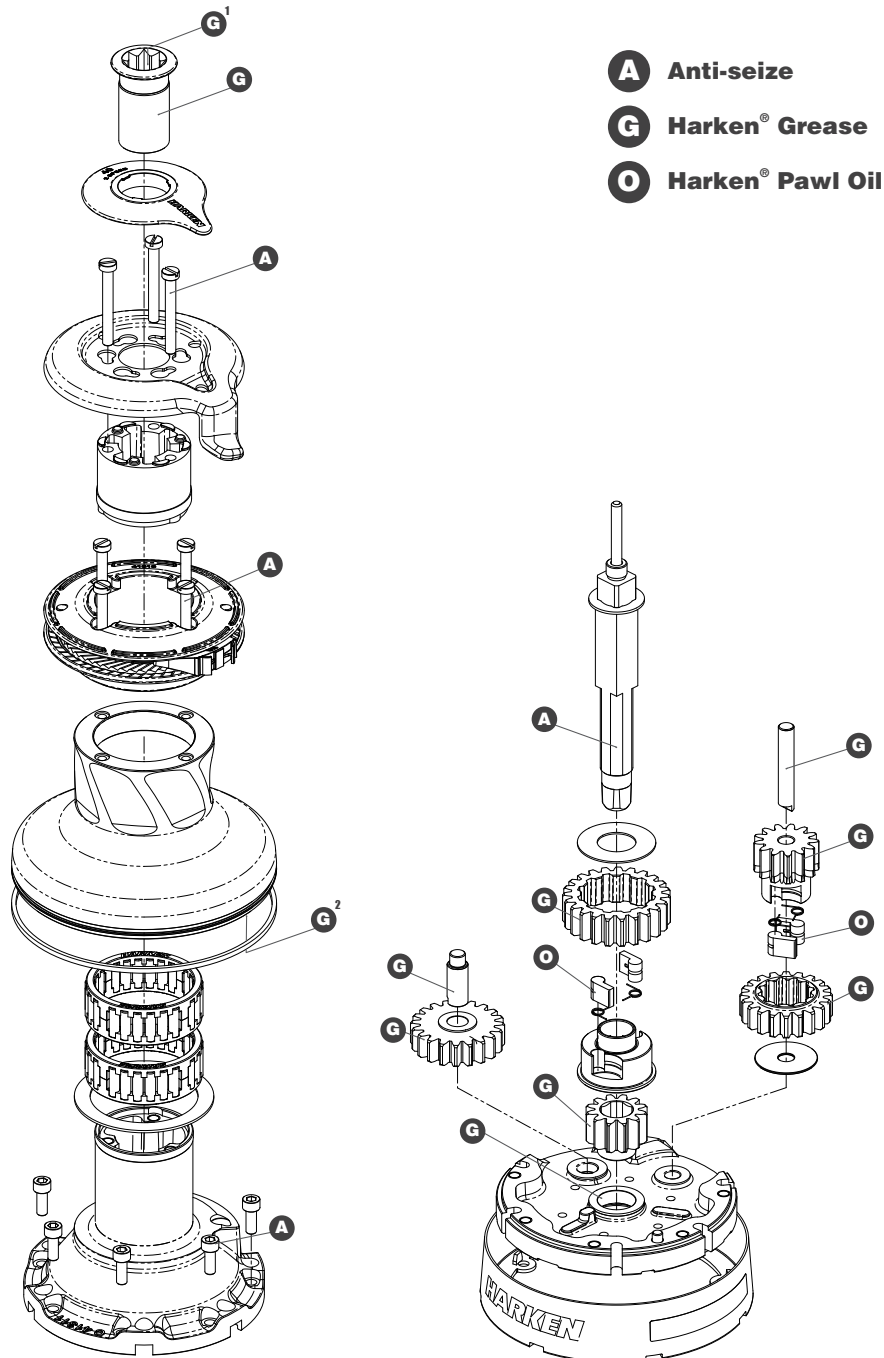

Apply Harken® grease where indicated above
 Apply Harken® grease: 1. on assy socket screw - 2. on drum gear

NOTICE

On every gear and every component that must be greased, apply Harken® grease with a brush in a proper quantity as shown below:



NOTICE

Harken® grease to apply on all teeth: do not use excessive quantity of product to void wastes. If in contact with the pawls, an excess of grease can compromise the safety of the winch.

Assembly

Make sure that the holes and drainage channels in the base of the winch are not obstructed. Assemble the winch in the reverse order of the sequence in the section of disassembly.

To tighten bolts, use the torque indicated in the disassembly procedure.



When positioning the stripper arm, align the peeler with it.



If the jaws have been disassembled, insert peeler between the two jaws, taking care that the letters TOP on the peeler are facing upwards.

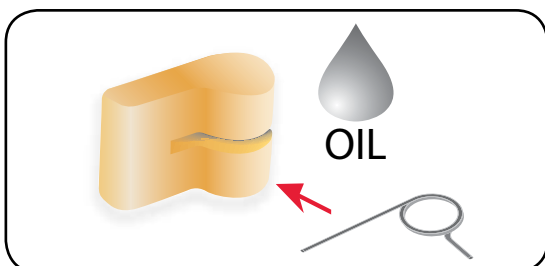

To assemble the pawls

Correctly position the spring in its housing as shown at left. Hold the spring closed and slide the pawl into its housing. Once in position, check that the pawls can be easily opened and closed with a finger.

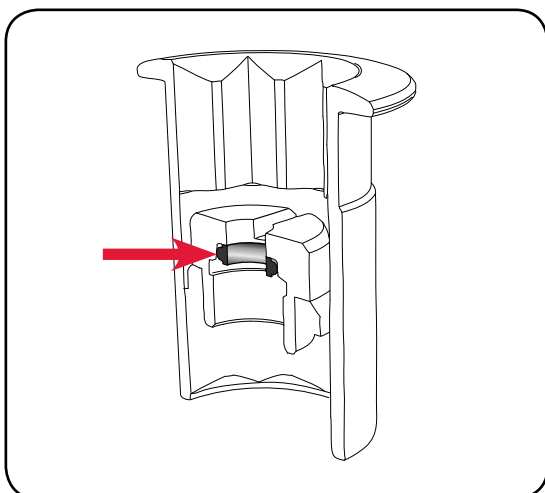

NOTICE

Before screw the central screw, check the correct position of the o-ring in the assy socket and apply Harken® grease.

In case of doubt concerning the assembly procedure contact Harken® Tech Service: techservice@harken.it

Harken® limited worldwide warranty

Refer to the Harken® Limited Worldwide Warranty in the Harken® Catalogue and on the website www.harken.com

Ordering spare parts

Spare parts can be requested from Harken® as described in the Harken® Limited Worldwide Warranty, indicating the part number in the Parts List and including the serial number of the winch for which the parts are required.

The serial number of the winch is printed on a plate on the drum support of the winch.

**Manufacturer*****Harken® Italy S.p.A.***

Via Marco Biagi, 14
22070 Limido Comasco (CO) Italy
Tel: (+39) 031.3523511
Fax: (+39) 031.3520031
Email: info@harken.it
Web: www.harken.com

- **Tech Service**
Email: techservice@harken.it
- **Customer Service**
Tel: (+39) 031.3523511
Email: info@harken.it

Headquarters***Harken®, Inc.***

1251 East Wisconsin Avenue
Pewaukee, Wisconsin 53072-3755 USA
Tel: (262) 691.3320
Fax: (262) 691.3008
Email: harken@harken.com
Web: www.harken.com

- **Tech Service**
Email: technicalservice@harken.com
- **Customer Service**
Tel: (262) 691-3320
Email: customerservice@harken.com

Exploded view

Radial Winch 35.2 STA, STC, STCW EL

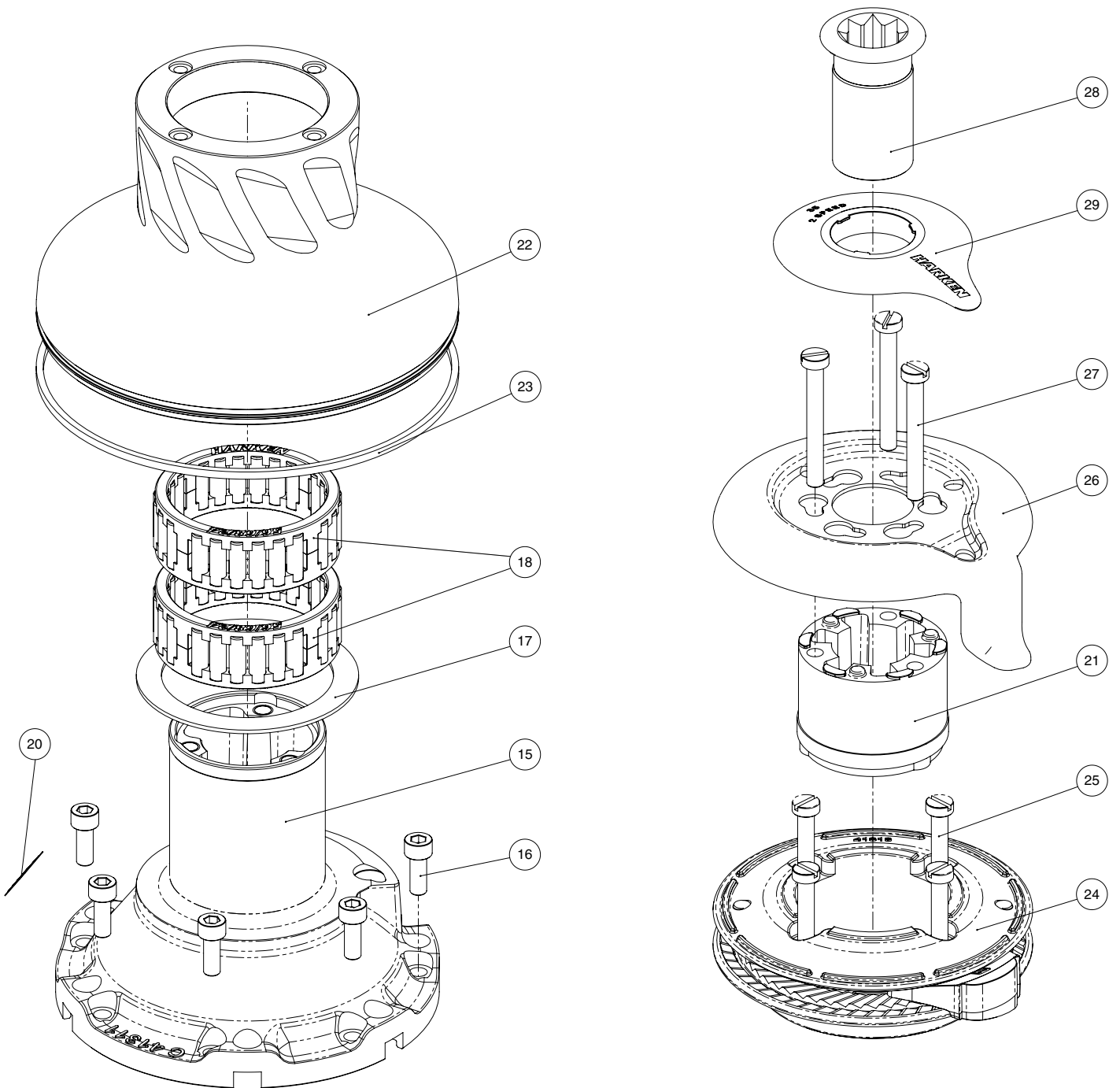

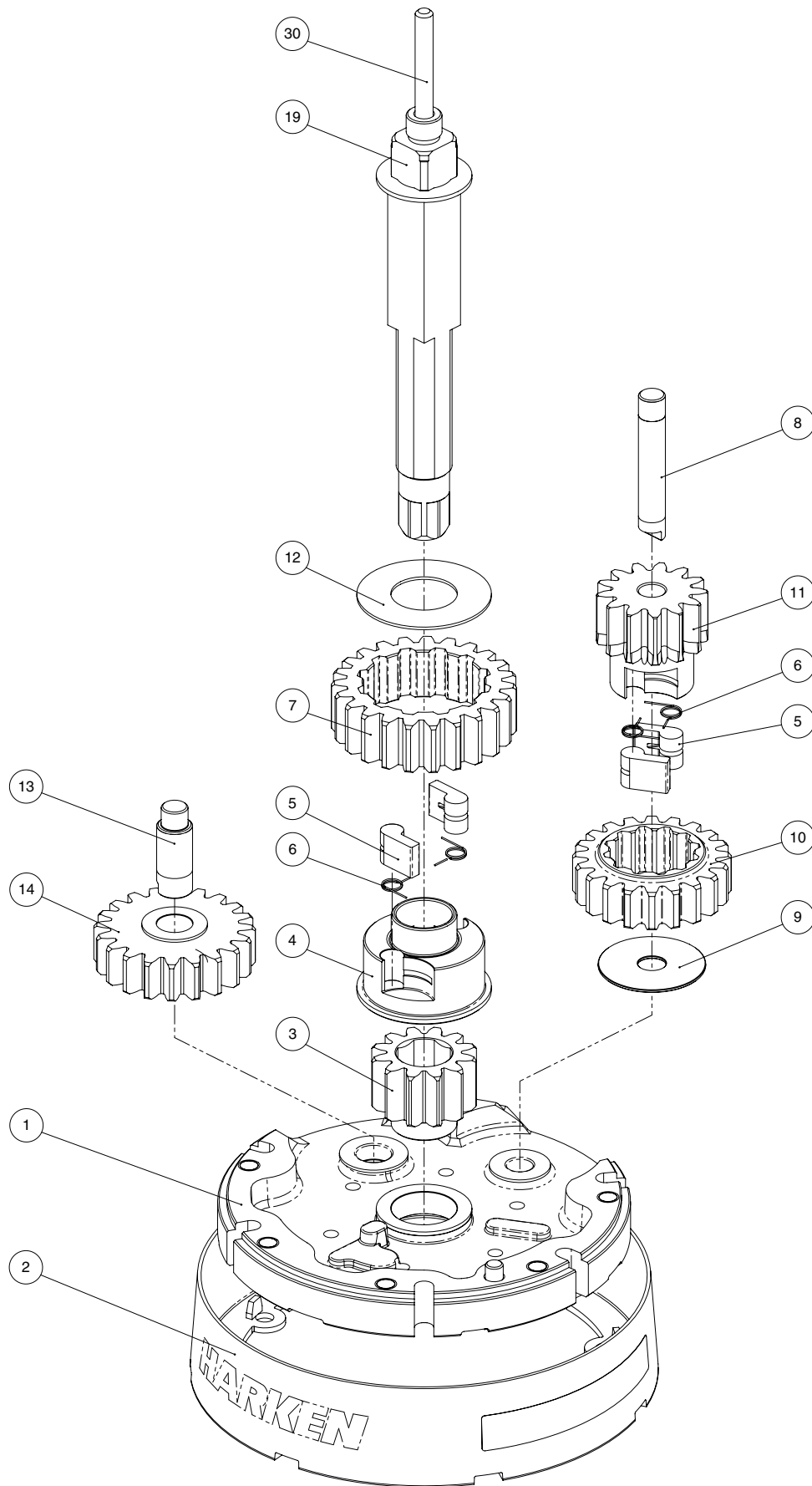
Radial Winch 35.2 STA, STC, STCW EL

Parts List

Radial Winch 35.2 STA EL

A = drum in anodised aluminium

Pos.	Q.ty	Code	Description	Pos.	Q.ty	Code	Description
1	1	A97021500	Assembly Base Winch 35 EL/HY	17	1	S413150082	Washer Ø62xØ80x1.5
	1	S413350080	Base W35	18	2	A74136000	Bearing Ø56xØ68x24
	1	S4130900A7	Roller Ø6x19	19	1	A94149600	Assembly Central Shaft W35EL/HY
	1	S413960085	Bushing Ø22xØ25x8.5				Central Shaft Pred. W35
	1	S413330085	Bushing Ø9xØ11x12	1	1	S413880002	Washer Ø17.2xØ32x1.5
	1	S413330085	Bushing Ø12xØ14x11	20			Winch Serial Number Sticker
2	1	A94131400	Assembly Skirt Winch 35	21	1	S4129400A0	Stripper arm support
			Skirt W35	22	1	S413160053	Drum A W35
			Winch Product Sticker**	23	1	S281680097	Red line
3	1	S413020004	Gear Z12	24	1	A94131800	Assembly Winch 35 Jaws
4	1	S413030004	Pawls Carrier Ø8xN2				Lower Jaw W35/40
5	4	S000080003	Pawl Ø8*				Upper Jaw W35/40
6	4	S000380001	Pawl Spring Ø8*				Peeler W20 - 40
7	1	S412830041	Gear Z23	1	1	S413610080	Spring
8	1	S413000004	Pin Ø9x55	4	4	S385970001	
9	1	S279090002	Washer Ø36xØ9,5x1	25	4	M0601803	Screw UNI EN ISO 1207 - M6x35 - A4
10	1	S415650004	Ratchet gear Z18	26	1	S414200019	Stripper Arm W35/40
11	1	S412850041	Pinion Z13	27	3	M6007103	Screw M6x50 UNI6107
12	1	S413120002	Washer Ø22.5xØ45x1	28	1	A94149300	Assembly Socket W35-80 EL/HY
13	1	S413070004	Pin Ø9xØ12x32.5				Socket Handle W20/80
14	1	A94130500	Assembly Gear Z20	1	1	S414940085	Washer Ø25xØ15x4
			Gear Z20	1	1	S414930003	Nut Screw for Disconnect Rod
	2	S414900080	Bushing Ø12xØ14x8	1	1	M0679797	O ring RC 2025 series
15	1	A94131100	Assembly Housing Winch 35	29	1	S4129500A5	Cover 2 speed W35
			Support W35	30	1	S414970002	Disconnect Rod W35 EL/HY
	2	S414890080	Bushing Ø9xØ11x7				
	1	S4130900A7	Bushing Ø22xØ25x8.5				
16	6	M0635103	Socket head screw M6x16 UNI 5931				

*Available with service kit; see website www.harken.com

**Winch product sticker



Radial Winch 35.2 STC EL

C = drum in chrome bronze

Pos.	Q.ty	Code	Description	Pos.	Q.ty	Code	Description
1	1	A97021500	Assembly Base Winch 35 EL/HY	17	1	S413150082	Washer Ø62xØ80x1.5
	1	S413350080	Base W35	18	2	A74136000	Bearing Ø56xØ68x24
	1	S4130900A7	Roller Ø6x19	19	1	A94149600	Assembly Central Shaft W35EL/HY
	1	S413960085	Bushing Ø22xØ25x8.5		1	S413880002	Central Shaft Pred. W35
	1	S413330085	Bushing Ø9xØ11x12				Washer Ø17.2xØ32x1.5
	1	S413330085	Bushing Ø12xØ14x11	20			Winch Serial Number Sticker
2	1	A94131400	Assembly Skirt Winch 35	21	1	S4129400A0	Stripper arm support
			Skirt W35	22	1	S413170043	Drum Winch 35 C
			Winch Product Sticker**	23	1	S281680097	Red line
3	1	S413020004	Gear Z12	24	1	A94131800	Assembly Winch 35 Jaws
4	1	S413030004	Pawls Carrier Ø8xN2		1	S413610080	Lower Jaw W35/40
5	4	S000080003	Pawl Ø8*		4	S385970001	Upper Jaw W35/40
6	4	S000380001	Pawl Spring Ø8*				Peeler W20 - 40
7	1	S412830041	Gear Z23				SPRING
8	1	S413000004	Pin Ø9x55	25	4	M0601803	Screw UNI EN ISO 1207 - M6x35 - A4
9	1	S279090002	Washer Ø36xØ9,5x1	26	1	S414200019	Stripper Arm W35/40
10	1	S415650004	Ratchet gear Z18	27	3	M6007103	Screw M6x50 UNI6107
11	1	S412850041	Pinion Z13	28	1	A94149300	Assembly Socket W35-80 EL/HY
12	1	S413120002	Washer Ø22.5xØ45x1		1	S414940085	Socket Handle W20/80
13	1	S413070004	Pin Ø9xØ12x32.5		1	S414930003	Washer Ø25xØ15x4
14	1	A94130500	Assembly Gear Z20		1	M0679797	Nut Screw for Disconnect Rod
			Gear Z20		1		O ring RC 2025 series
	2	S414900080	Bushing Ø12xØ14x8	29	1	S4129500A5	Cover 2 speed W35
15	1	A94131100	Assembly Housing Winch 35	30	1	S414970002	Disconnect Rod W35 EL/HY
			Support W35				
	2	S414890080	Bushing Ø9xØ11x7				
	1	S4130900A7	Bushing Ø22xØ25x8.5				
16	6	M0635103	Socket head screw M6x16 UNI 5931				

*Available with service kit; see website www.harken.com

**Winch product sticker



Radial Winch 35.2 STCW EL

CW = chrome/white

Pos.	Q.ty	Code	Description	Pos.	Q.ty	Code	Description
1	1	A97021500	Assembly Base Winch 35 EL/HY	17	1	S413150082	Washer Ø62xØ80x1.5
	1	S413350080	Base W35	18	2	A74136000	Bearing Ø56xØ68x24
	1	S4130900A7	Roller Ø6x19	19	1	A94149600	Assembly Central Shaft W35EL/HY
	1	S413960085	Bushing Ø22xØ25x8.5		1	S413880002	Central Shaft Pred. W35
	1	S413330085	Bushing Ø9xØ11x12				Washer Ø17.2xØ32x1.5
	1	S413330085	Bushing Ø12xØ14x11	20			Winch Serial Number Sticker
2	1	A94131400W	Assembly Skirt Winch 35 RAL9003	21	1	S4129400A0	Stripper arm support
			Skirt W35 RAL9003	22	1	S413170043	Drum Winch 35 C
			Winch Product Sticker**	23	1	S281680097	Red line
3	1	S413020004	Gear Z12	24	1	A94131800W	Assembly Winch 35 Jaws RAL9003
4	1	S413030004	Pawls Carrier Ø8xN2		1	S413610080W	Lower Jaw W35/40 RAL9003
5	4	S000080003	Pawl Ø8*		4	S385970001	Upper Jaw W35/40 RAL9003
6	4	S000380001	Pawl Spring Ø8*				Peeler W20 - 40 RAL9003
7	1	S412830041	Gear Z23				SPRING
8	1	S413000004	Pin Ø9x55	25	4	M0601803	Screw UNI EN ISO 1207- M6x35 - A4
9	1	S279090002	Washer Ø36xØ9,5x1	26	1	S414200019	Stripper Arm W35/40
10	1	S415650004	Ratchet gear Z18	27	3	M6007103	Screw M6x50 UNI6107
11	1	S412850041	Pinion Z13	28	1	A94149300	Assembly Socket W35-80 EL/HY
12	1	S413120002	Washer Ø22.5xØ45x1		1	S414940085	Socket Handle W20/80
13	1	S413070004	Pin Ø9xØ12x32.5		1	S414930003	Washer Ø25xØ15x4
14	1	A94130500	Assembly Gear Z20		1	M0679797	Nut Screw for Disconnect Rod
			Gear Z20		1		O ring RC 2025 series
	2	S414900080	Bushing Ø12xØ14x8	29	1	S4129500A5W	Cover 2 speed W35 RAL9003
15	1	A94131100	Assembly Housing Winch 35	30	1	S414970002	Disconnect Rod W35 EL/HY
			Support W35				
	2	S414890080	Bushing Ø9xØ11x7				
	1	S4130900A7	Bushing Ø22xØ25x8.5				
16	6	M0635103	Socket head screw M6x16 UNI 5931				

*Available with service kit; see website www.harken.com

**Winch product sticker

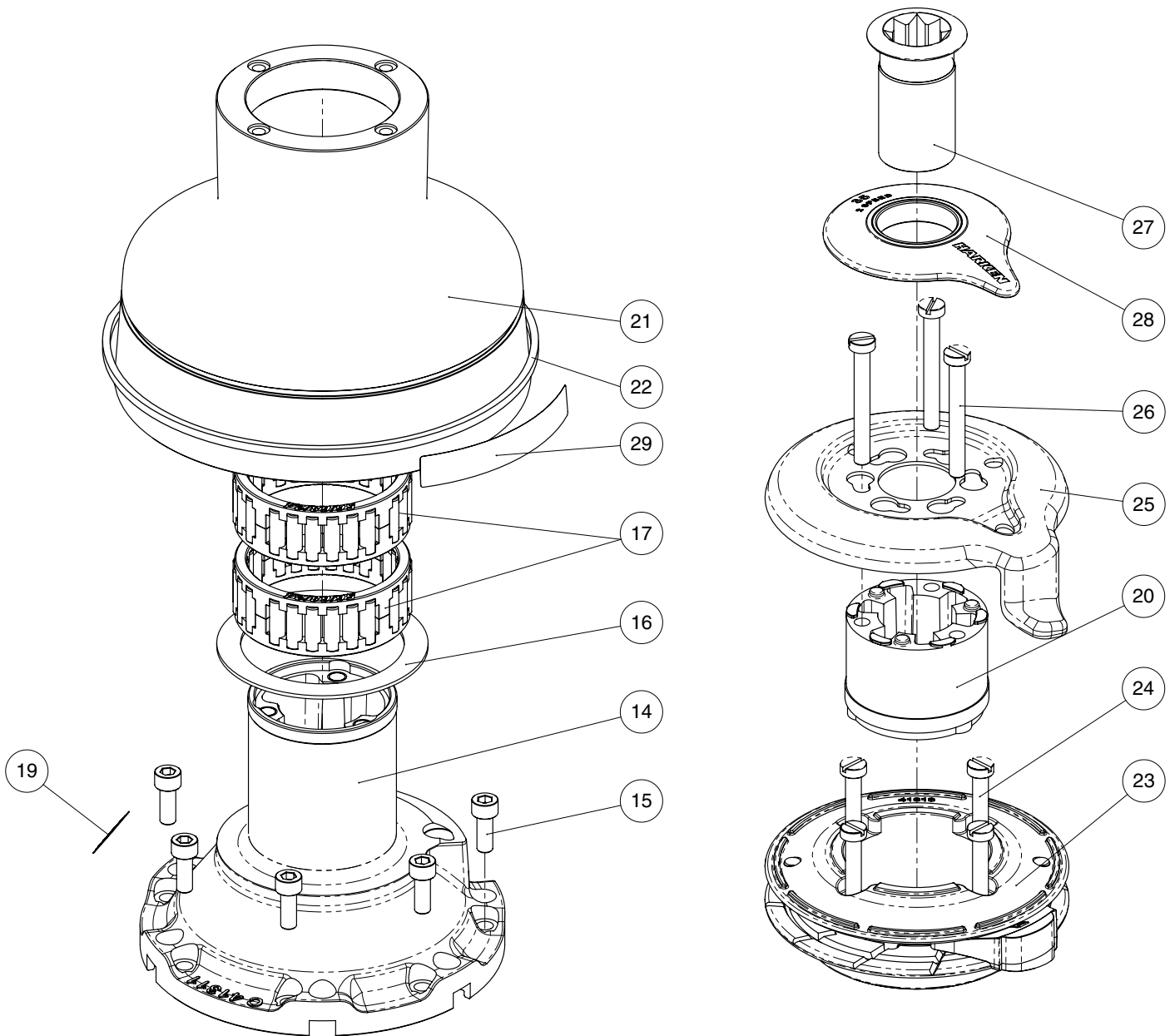

Radial Winch 35.2 STBBB, STCCC EL

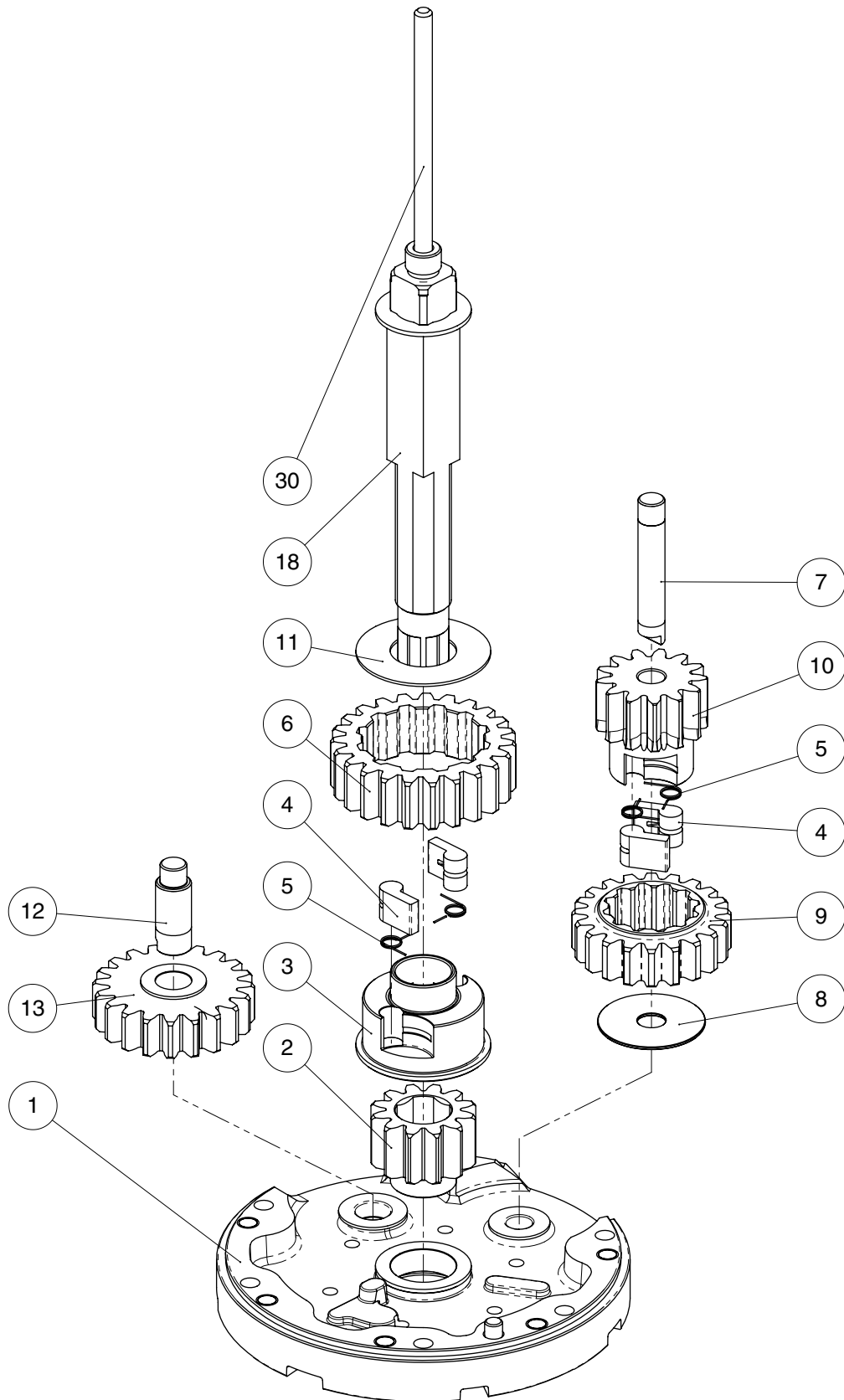
Radial Winch 35.2 STBBB, STCCC EL

Radial Winch 35.2 STBBB EL

BBB = all bronze

Pos.	Q.ty	Code	Description	Pos.	Q.ty	Code	Description
1	1	A97160700	Assembly base Winch 35 BBB/CCC EL/HY <i>Base W35</i>	17	2	A74136000	Bearing Ø56xØ68x24
	1	S413350080	<i>Roller Ø6x19</i>	18	1	A94149600	Assembly Central Shaft W35EL/HY <i>Central Shaft Pred. W35</i>
	1	S4130900A7	<i>Bushing Ø22xØ25x8.5</i>		1	S413880002	<i>Washer Ø17.2xØ32x1.5</i>
	1	S413960085	<i>Bushing Ø9xØ11x12</i>	19			Winch Serial Number Sticker
	1	S413330085	<i>Bushing Ø12xØ14x11</i>	20	1	S4129400A0	Stripper arm support
2	1	S413020004	Gear Z12	21	1	S688170043	Drum W35 BBB
3	1	S413030004	Pawls Carrier Ø8xN2	22	1	S281680097	Red line
4	4	S000080003	Pawl Ø8*	23	1	A96932800	Assembly Jaws Winch 35/40 BBB <i>Lower Jaw W35/40 BBB</i>
5	4	S000380001	Pawl Spring Ø8*				<i>Upper Jaw W35/40</i>
6	1	S412830041	Gear Z23		1	S413610080	<i>Peeler W20 - 40</i>
7	1	S413000004	Pin Ø9x55		4	S385970001	<i>Spring</i>
8	1	S279090002	Washer Ø36xØ9,5x1	24	4	M0601803	Screw UNI EN ISO 1207- M6x35 - A4
9	1	S415650004	Ratchet Gear Z18	25	1	S7123000F0	Stripper arm W35/40 BBB
10	1	S412850041	Pinion Z13	26	3	M6007103	Screw M6x50 UNI6107
11	1	S413120002	Washer Ø22.5xØ45x1	27	1	A94149300	Assembly Socket W35-80 EL/HY <i>Socket Handle W20/80</i>
12	1	S413070004	Pin Ø9xØ12x32.5		1	S414940085	<i>Washer Ø25xØ15x4</i>
13	1	A94130500	Assembly Gear Z20 <i>Gear Z20</i>		1	S414930003	<i>Nut Screw for Disconnect Rod</i>
	2	S414900080	<i>Bushing Ø12xØ14x8</i>		1	M0679797	<i>O ring RC 2025 series</i>
14	1	A94131100	Assembly housing Winch 35 <i>Housing Winch 35</i>	28	1	A76932700	Cover 2 speed W35 BBB
	2	S414890080	<i>Bushing Ø9xØ11x7</i>	29			Winch Product Sticker**
	1	S4130900A7	<i>Bushing Ø22xØ25x8.5</i>	30	1	S414970002	Disconnect Rod W35 EL/HY
15	6	M0635103	Socket head screw M6x16 UNI 5931				
16	1	S413150082	Washer Ø62xØ80x1.5				

*Available with service kit; see website www.harken.com

**Winch product sticker



Radial Winch 35.2 STCCC EL

CCC = All-Chrome bronze

Pos.	Q.ty	Code	Description	Pos.	Q.ty	Code	Description
1	1	A97160700	Assembly Base Winch 35 BBB/CCC EL/HY	16	1	S413150082	Washer Ø62xØ80x1.5
	1	S413350080	Base W35	17	2	A74136000	Bearing Ø56xØ68x24
	1	S4130900A7	Roller Ø6x19	18	1	A94149600	Assembly Central Shaft W35EL/HY
	1	S413960085	Bushing Ø22xØ25x8.5				Central Shaft Pred. W35
	1	S413330085	Bushing Ø9xØ11x12	1	1	S413880002	Washer Ø17.2xØ32x1.5
	1	S413330085	Bushing Ø12xØ14x11	19			Winch Serial Number Sticker
2	1	S413020004	Gear Z12	20	1	S4129400A0	Stripper arm support
3	1	S413030004	Pawls Carrier Ø8xN2	21	1	S681040043	Drum CCC W35
4	4	S000080003	Pawl Ø8*	22	1	S281680097	Red line
5	4	S000380001	Pawl Spring Ø8*	23	1	A96811900	Assembly Jaws Winch 35/40 CCC
6	1	S412830041	Gear Z23				Lower Jaw W35/40 CCC
7	1	S413000004	Pin Ø9x55	1	1	S413610080W	Upper Jaw W35-40 RAL9003
8	1	S279090002	Washer 36x9,5x1	4	4	S385970001	Peeler W20 - 40 RAL9003
9	1	S415650004	Ratchet Gear Z18				SPRING
10	1	S412850041	Pinion Z13	24	4	M0601803	Screw UNI EN ISO 1207 - M6x35 - A4
11	1	S413120002	Washer Ø22.5xØ45x1	25	1	S414200019	Stripper Arm W35/40
12	1	S413070004	Pin Ø9xØ12x32.5	26	3	M6007103	Screw M6x50 UNI6107
13	1	A94130500	Assembly Gear Z20	27	1	A94149300	Assembly Socket W35-80 EL/HY
	2	S414900080	Gear Z20				Socket Handle W20/80
			Bushing Ø12xØ14x8	1	1	S414940085	Washer Ø25xØ15x4
14	1	A94131100	Assembly Housing Winch 35	1	1	S414930003	Nut Screw for Disconnect Rod
	2	S414890080	Housing Winch 35	1	1	M0679797	O ring RC 2025 series
	1	S4130900A7	Bushing Ø9xØ11x7	28	1	A76811100	Cover W35 CCC
	1	S4130900A7	Bushing Ø22xØ25x8.5	29			Winch Product Sticker**
15	6	M0635103	Socket head screw M6x16 UNI 5931	30	1	S414970002	Disconnect Rod W35 EL/HY

*Available with service kit; see website www.harken.com

**Winch product sticker



Horizontal electric motor 12V/24V

TOP VIEW

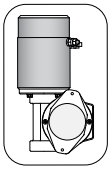

* **Motor installed in right-hand configuration.**

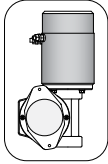

** **Motor installed in left-hand configuration.**

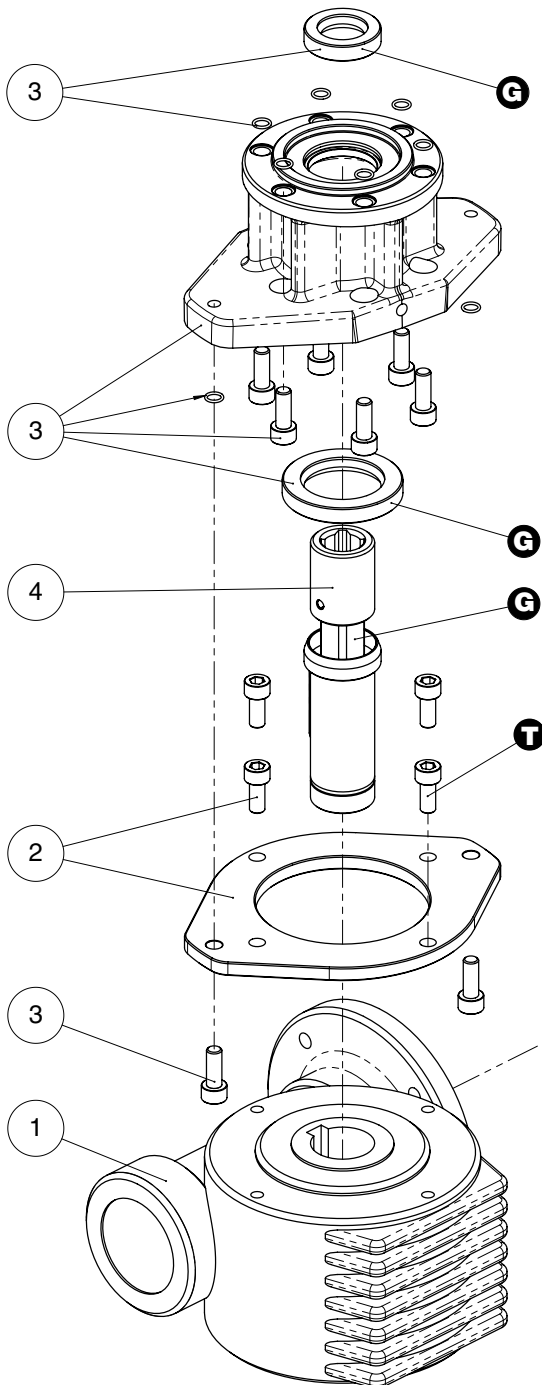

Pos.	Q.ty	Code	Description
1	1	A93127900	KIT Gear Reduction 1/24
	1	A94194900	KIT LM Gear Reduction 1/24
2	1	A94149200	KIT Assy Electric Motor Flange
	1	A94149200L	KIT Assy Electric Motor Flange Left
	4	M0606803	Electric Motor Flange Screw M6x14 UNI 5931
	8	M0612097	Sealer Ø30xØ47x7
3	1	A94149500	KIT EL HO Motor Flange
	8	S415360003	Horizontal Motorgear Flange Screw M6x16 UNI EN ISO 5931:2003 precote coating
	8	M601560097	O-Ring Seal (Ø5,5 x Ø1)
	1	M6007297	Lip seal Ø17xØ30x7
4	1	A94161600	KIT EL HO Motor Clutch
	1	M0601402	Shaft Motorgear HO
	1	M6020097	Shaft GearMotor HO
	1	S418620001	Hub GearMotor
	1	S414050080	Disconnect spring
	1	M6010303	Flange GearMotor Shaft HO
	1	M6010303	Key 8x5x40 UNI 7511
5	1	A96015400	KIT EL Motor 12V 0,7kW
	1	A96015700	KIT EL Motor 24V 0,9kW
	1		Electric Motor
	1		Polarity motor sticker
	1		Screw stud M6x26
	1		Washer Ø6
	1		Nut M6 UNI5588
1	M6014206	Key DIN 6885 5x5x15	

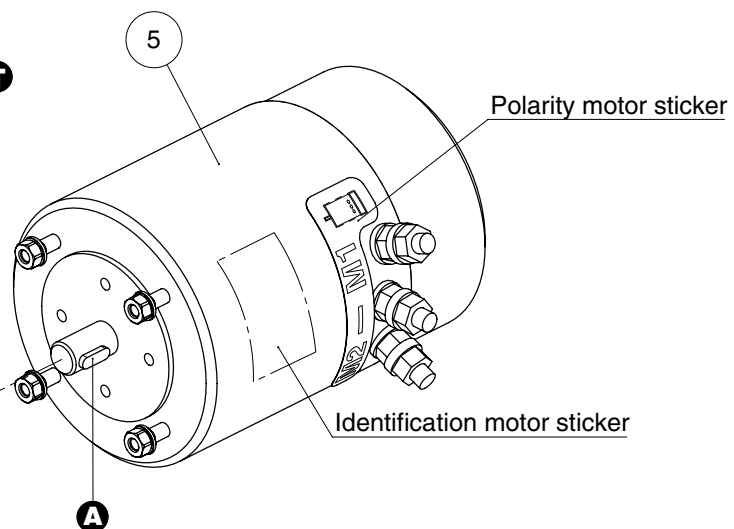

- A** Anti-seize
- G** Harken® Grease
- T** Axial Threadlocker