

DRAGONFLY

SONAR / GPS



Raymarine®



A New Species of Sonar

View the world beneath your boat with the photo-like clarity of Dragonfly's DownVision™ sonar, the first high-resolution imaging sonar for anglers to use CHIRP technology. Dragonfly's dual channel CHIRP sonar lets you explore structure and target fish like never before.



Unmatched Noise Reduction

Enhanced CHIRP DownVision™ Resolution

Dual Channel CHIRP Sonar

Go Deeper: DownVision and Sonar Images down to 600ft



Serious Technology for Everyone

Whether you are a professional guide or weekend bass angler, you will appreciate Dragonfly's cutting edge sonar performance and simple operation. Simply dial through sonar and GPS displays and quickly become a Dragonfly expert.



Easy Screen Switcher

Automatic Sonar Optimization; No Adjustment Required

Simple Three Button Control

Just Power On and Fish!



Dragonfly™ Key Features

- Photo-like imagery of bottom structure using CHIRP DownVision™
- CHIRP powered Dual Channel sonar; view high resolution DownVision structure imagery and target fish with CHIRP sonar simultaneously
- Perfectly matched dual beam CHIRP transducer
- Fast response temperature sensor built into the transducer
- Built in 50-channel GPS sensor with fast-acquisition technology
- Available with industry leading, Navionics charts included on microSD
- Uncomplicated user interface simplifies display choices and menu options
- Ultra-bright 1500 nit optically bonded sunlight display for maximum readability in all conditions
- Tilt/swivel quick release holster with optional locking core for added security

CHIRP Sonar Technology

Unlike conventional imaging sonars that transmit a single frequency with each pulse, Dragonfly's DownVision™ sonar uses CHIRP technology to transmit across a wide spectrum of sonar frequencies with each pulse – the result is much higher-resolution, life-like sonar images.

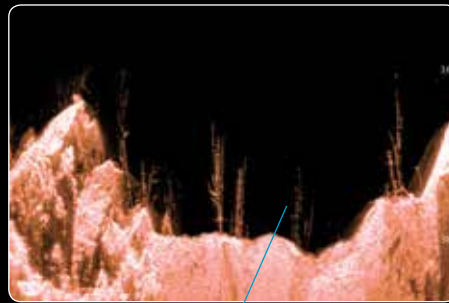

Submerged trees



Submerged boat with bait fish

Submerged dock structure



Submerged airplane cockpit



Dual Channel CHIRP – Two Sonars in One

Dragonfly is built with two discrete CHIRP sonar channels. The first is the ultrahigh-resolution DownVision channel and the second is a high-resolution fish targeting sonar channel. View each sonar channel independently or switch to dual sonar split screen mode for the ultimate in underwater intelligence.

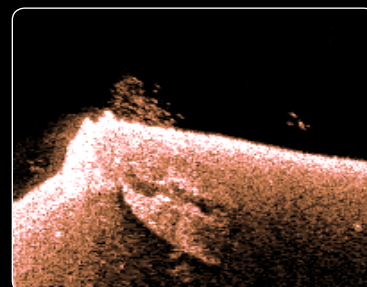

High-resolution DownVision detail

The same location reveals individual fish targets in sonar mode

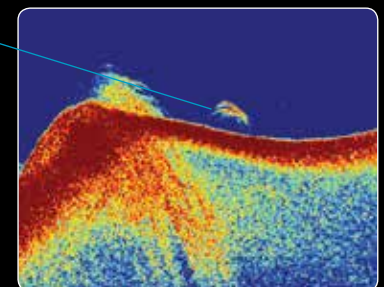

CPT-60 Transducer - The Perfect Match

For maximum performance, Dragonfly is paired with Raymarine's exclusive CPT-60 dual element CHIRP transducer. Engineered to be a perfect acoustical match to Dragonfly's CHIRP sonar, the CPT-60 is equipped with an ultra wide fan shaped beam for a wide view of DownVision images. The CPT-60 second element provides a conical shaped beam for imaging fish targets, ensuring you will never miss any of the action below your boat. The CPT-60's hydrodynamic design provides excellent high-speed performance, and an optional trolling motor mount offers added mounting flexibility.



Ultra wide DownVision™

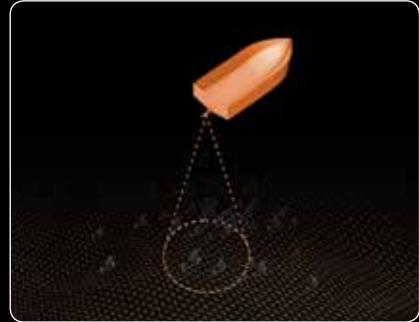

Fish Targeting Sonar



Internal 50 channel fast acquisition GPS

Super Bright 1500 nit optically bonded display

Uni-controller - joystick cursor and rotary dial

MicroSD chart and memory reader



Great Visibility and Great Fit

Dragonfly features a large 5.7" ultra-bright 1500 nit color display that is optically bonded for maximum visibility and high contrast even in the bright summer sun. Dragonfly's tilt and swivel mounting holster has a small mounting footprint, making it easy to mount Dragonfly anywhere on board. For added on board security, Dragonfly's convenient quick-release tilt and swivel holster can be secured with an optional Thule locking cylinder. An optional flush mounting kit is also available.

Rugged enclosure built to IPX6 and IPX7 waterproof and submersion standards

Single power and transducer connector with thumb-friendly locking collar

Optional Thule locking cylinder for enhanced security

Tilt and swivel holster with quick release



General Specifications

Nominal supply voltage	12v
Operating voltage range	10.2 – 16.6v
Power consumption at full brightness	8 watts
Connections	Power/transducer combined input
Waterproofing standard	IPX6 and IPX7
Display size	5.7" (4:3 aspect ratio)
Display resolution	VGA (640 x 480)
Brightness	1500 nits
GPS and Cartography	
GPS	Internal 50 channel fast acquisition GPS
Chart Compatibility	Navionics Silver, Gold and HotMaps
Waypoints	3000
Tracks	15 tracks of up to 10,000 trackpoints
Chart Media	microSD
Sonar	
Sonar Type	CHIRP Sonar
Sonar Channels	2
Depth Range	600 ft (183 meters) in both DownVision and Sonar modes
Warranty	1 Year Warranty with Raymarine RapidCare™ support

DISPLAY AND BRACKET DIMENSIONS

- A 5.8 in (148 mm)
- B 5.8 in (148.3 mm)
- C 8.4 in (212.3 mm)
- D 0.7 in (17 mm)
- E 2.2 in (56 mm)
- F 3.5 in (90 mm)

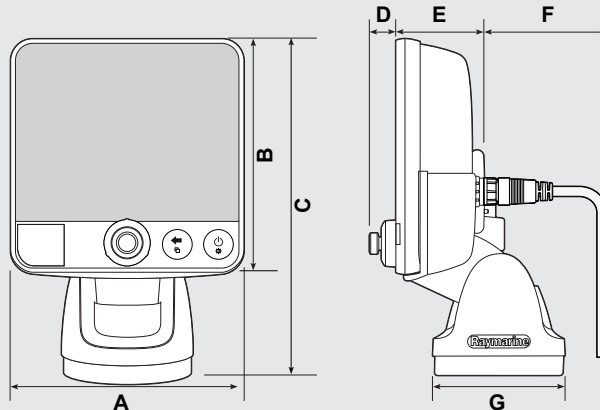

TRANSDUCER DIMENSIONS

- A 8 in (202.6 mm)
- B 4.6 in (117.4 mm)

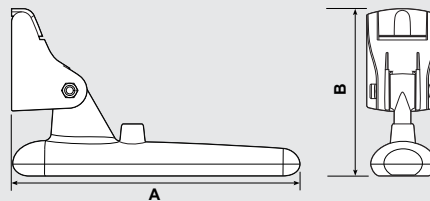

The information contained in this brochure, to the best of our knowledge, was correct as it went to press. Raymarine's policy of continuous improvement and updating may change product specifications without prior notice. Differences between the product and this brochure may occur, for which liability cannot be accepted by Raymarine. Some images are for illustrative purposes only.



Raymarine Inc.
9 Townsend West
Nashua
NH 03063
USA
T: 603.324.7900

CONNECT WITH RAYMARINE ONLINE

facebook twitter YouTube

www.raymarine.com/dragonfly

Product specifications subject to change without notice. Imagery for illustrative purposes only.