



echoMAP™ 70/90 Series Installation Instructions

To obtain the best performance and to avoid damage to your boat, install the device according to these instructions.

Read all installation instructions before proceeding with the installation. If you experience difficulty during the installation, contact Garmin® Product Support.

Important Safety Information

⚠ WARNING

See the *Important Safety and Product Information* guide in the product box for product warnings and other important information.

When connecting the power cable, do not remove the in-line fuse holder. To prevent the possibility of injury or product damage caused by fire or overheating, the appropriate fuse must be in place as indicated in the product specifications. In addition, connecting the power cable without the appropriate fuse in place voids the product warranty.

⚠ CAUTION

Always wear safety goggles, ear protection, and a dust mask when drilling, cutting, or sanding.

NOTICE

When drilling or cutting, always check what is on the opposite side of the surface.

To obtain the best performance and to avoid damage to your boat, install the device according to these instructions.

Read all installation instructions before proceeding with the installation. If you experience difficulty during the installation, contact Garmin Product Support.

Registering Your Device

Help us better support you by completing our online registration today.

- Go to <http://my.garmin.com>.
- Keep the original sales receipt, or a photocopy, in a safe place.

Contacting Garmin Product Support

- Go to www.garmin.com/support for in-country support information.
- In the USA, call 913-397-8200 or 1-800-800-1020.
- In the UK, call 0808 238 0000.
- In Europe, call +44 (0) 870 850 1241.

Tools Needed

- Drill and drill bits
- #2 Phillips screwdriver
- Jigsaw or rotary tool
- File and sandpaper
- Marine sealant (optional)

Mounting Considerations

The device can be mounted using the included bracket, or it can be mounted flush with the dashboard using a flush-mount kit (may be sold separately).

Before permanently installing any part of your device, you should plan the installation by determining the location of the various components.

- The mounting location must provide a clear view of the screen and access to the keys on the device.
- The mounting location must be sturdy enough to support the device and the mount.
- The cables must be long enough to connect the components to each other and to power.
- The cables can be routed under the bail mount or behind the device.
- To avoid interference with a magnetic compass, the device should not be installed closer to a compass than the compass-safe distance value listed in the product specifications.

Bail Mounting the Device

NOTICE

If you are mounting the bracket on fiberglass with screws, it is recommended to use a countersink bit to drill a clearance counterbore through only the top gel-coat layer. This will help to avoid any cracking in the gel-coat layer when the screws are tightened.

Stainless-steel screws may bind when screwed into fiberglass and overtightened. Garmin recommends applying an anti-seize lubricant to the screws before installing them.

- 1 Select the mounting hardware appropriate for your mounting surface and for the bail-mount bracket.
- 2 Using the bail-mount bracket ① as a template, mark the pilot holes through the screw holes ②.

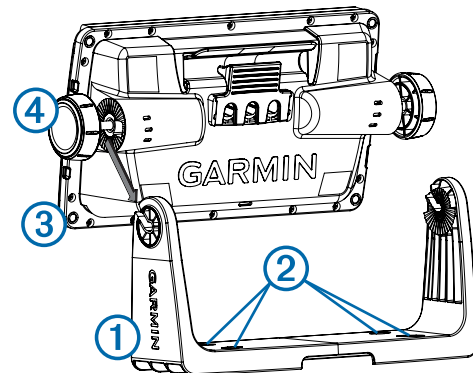

- 3 Using a drill bit appropriate for the mounting hardware, drill the four pilot holes.
- 4 Using the selected mounting hardware, secure the bail-mount bracket to the mounting surface.
- 5 Place the device into the cradle ③.
- 6 Install the bail-mount knobs ④ on the sides of the device.
- 7 Place the cradle in the bail-mount bracket and tighten the bail-mount knobs.

Flush Mounting the Device

NOTICE

Be careful when cutting the hole to flush mount the device. There is only a small amount of clearance between the case and the mounting holes, and cutting the hole too large could compromise the stability of the device after it is mounted.

Using a metal pry tool such as a screwdriver can damage the trim caps and the device. Use a plastic pry tool when possible.

A flush-mount template and hardware can be used to mount the device in your dashboard.

- 1 Trim the template and make sure it fits in the location where you want to mount the device.
- 2 Secure the template to the selected mounting location.
- 3 Using a 9.5 mm (³/₈ in.) drill bit, drill one or more of the holes inside the corners of the solid line on the template to prepare the mounting surface for cutting.
- 4 Using a jigsaw or rotary cutting tool, cut the mounting surface along the inside of the solid line indicated on the template.
- 5 Place the device into the cutout to test the fit.
- 6 If necessary, use a file and sandpaper to refine the size of the hole.
- 7 **NOTE:** Not all devices have trim caps.

Using a pry tool such as a flat piece of plastic or a screwdriver, carefully pry up the corners of the trim caps ① and slide the pry tool to the center ② to remove the trim caps.

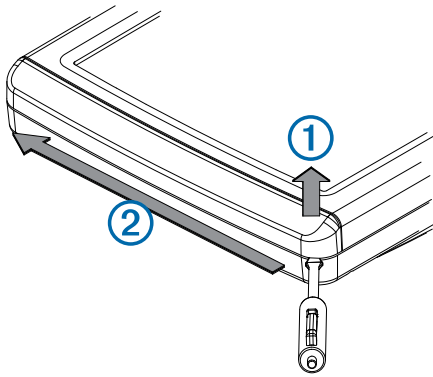

- 8 Ensure the mounting holes on the device line up with the pilot holes on the template.
- 9 If the mounting holes on the device do not line up, mark the new pilot-hole locations.
- 10 Using a 3.2 mm (¹/₈ in.) drill bit, drill the pilot holes.
- 11 Remove the template from the mounting surface.
- 12 If you will not have access to the back of the device after you mount it, connect all necessary cables to the device before placing it into the cutout.

NOTE: To prevent corrosion of the metal contacts, cover unused connectors with weather caps.
- 13 Install the rubber gasket pieces on the back of the device.

The pieces of the rubber gasket have adhesive on the back. Make sure you remove the protective liner before installing them on the device.

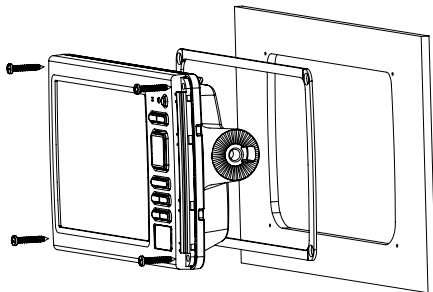

- 14 Place the device into the cradle.
- 15 Securely connect each cable to a port on the cradle.
- 16 Place the locking bracket over the cables.
- 17 Place the device into the cutout.

18 Secure the device to the mounting surface using the included screws.

19 Install the trim caps by snapping them in place around the edges of the device.

Wiring Harness

- The wiring harness connects the device to power and NMEA® 0183 devices.
- The device has one internal NMEA 0183 port that is used to connect to NMEA 0183 compliant devices.
- If it is necessary to extend the power and ground wires, you must use .82 mm² (18 AWG) or larger wire.
- If it is necessary to extend the NMEA 0183 or alarm wires, you must use 22 AWG (.33 mm²) wire.

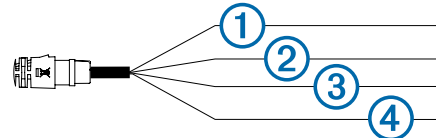

Item	Wire Function	Wire Color
①	NMEA 0183 internal port Rx (in)	Brown
②	NMEA 0183 internal port Tx (out)	Blue
③	Ground (power and NMEA 0183)	Black
④	Power	Red

Connecting the Wiring Harness to Power

- 1 Route the wiring harness to the power source and to the device.
- 2 Connect the red wire to the positive (+) battery terminal, and connect the black wire to the negative (-) battery terminal.

NMEA 0183 Connection Considerations

- The installation instructions provided with your NMEA 0183 compatible device should contain the information you need to identify the transmitting (Tx) and receiving (Rx) A (+) and B (-) wires.

NMEA 0183 Connection Diagram

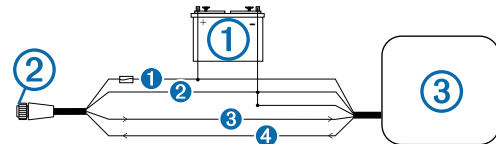

Item	Description
①	12 Vdc power source
②	Wiring harness
③	NMEA 0183-compliant device

Item	Garmin Wire Function	Garmin Wire Color	NMEA 0183 Device Wire Function
①	Power	Red	Power
②	Ground	Black	Data ground
③	Tx	Blue	Rx/A (+)
④	Rx	Brown	Tx/A (+)

Installing the Cables and Connectors

Wiring to Power

- 1 Route the power cable from the swivel mount to the boat battery or fuse block.
- 2 If necessary, extend the wires using .82 mm² (18 AWG) or larger wire.
- 3 Connect the red wire to the positive terminal on the battery or fuse block, and connect the black wire to the negative terminal.

Connecting the Device to a Transducer

NOTE: The device goes into simulator mode if the connection is not secure between the device and transducer.

Go to www.garmin.com or contact your local Garmin dealer to determine the appropriate type of transducer for your needs.

- 1 Follow the instructions provided with your transducer to correctly install it on your boat.
- 2 Route the transducer cable to the back of your device, away from sources of electrical interference.
- 3 Connect the transducer cable to the appropriate port on your device.

Connecting the Cables to the Cradle

The connectors on the cables are keyed to fit only in the correct ports on the device or cradle. The connected cables are held in place by a locking bracket.

- 1 Remove the cable locking bracket from the cradle.
- 2 Compare the divots ① on each cable connector to the keying on each port to determine which cable corresponds to each port.

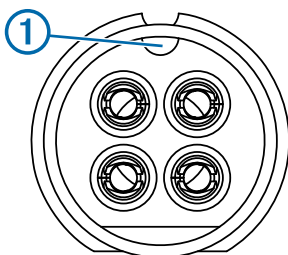

- 3 Securely connect each cable to a port.
- 4 Place the locking bracket ② over the cables and slide the bracket down to lock the cables in place.

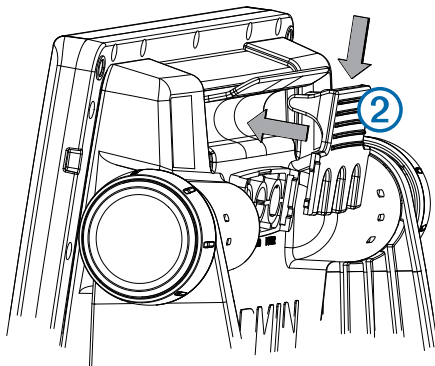

There is an audible click when the locking bracket is installed correctly.

Installing the Device in the Cradle

If your device uses a cradle and you have connected the cables to the cradle, you can quickly place the device in the cradle without plugging in any cables.

- 1 Place the base of the device in the bottom of the cradle.
- 2 Tilt the device toward the cradle until it fastens in place.

There is an audible click when the device is secured in the cradle.

Removing the Device from the Cradle

- 1 Press the release lever ① on the cradle until the device is released.

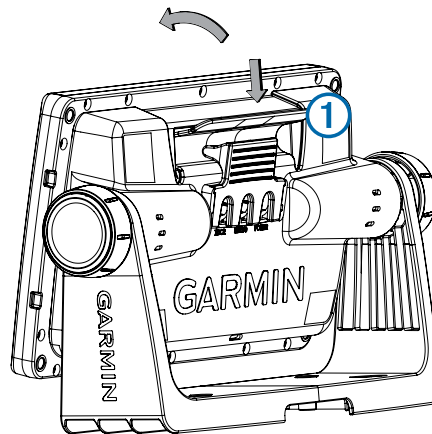

- 2 Tilt the device forward, and lift it out of the cradle.

Updating the Device Software

Before you can update the software, you must obtain a software-update memory card or load the latest software onto a memory card.

- 1 Turn on the chartplotter.
- 2 After the home screen appears, insert the memory card into the card slot.

NOTE: In order for the software update instructions to appear, the device must be fully booted before the card is inserted.

- 3 Follow the on-screen instructions.
- 4 Wait several minutes while the software update process completes.

The device returns to normal operation after the software update process is complete.

- 5 Remove the memory card.

NOTE: If the memory card is removed before the device restarts fully, the software update is not complete.

Specifications

Device	Specification	Measurement
echoMAP 70	Dimensions (W x H x D)	25 x 13.9 x 5.1 cm (9.8 x 5.5 x 2 in.)
	Display size (W x H)	15.2 x 9.1 cm (6.0 x 3.6 in.)
	Weight	0.77 kg (1.7 lbs.)
	Power input	From 10 to 18 Vdc
	Max. power usage	20 W
	Compass-safe distance	65 cm (25.6 in.)
echoMAP 90	Dimensions (W x H x D)	28.8 x 16.3 x 5.1 cm (11.3 x 6.4 x 2 in.)
	Display size (W x H)	19.8 x 11.2 cm (4.4 x 7.8 in.)
	Weight	1 kg (2.3 lbs.)
	Power input	From 10 to 20 Vdc
	Max. power usage	11 W
All Models	Compass-safe distance	55 cm (21.7 in.)
	Temperature range	From -15 to 55°C (from 5 to 131°F)
	Material	Polycarbonate plastic
	Water rating	IEC 60529 IPX7
	Transmit power (RMS)**	500 W
	Maximum depth***	701 m (2300 ft) at 77 kHz
	Frequencies****	<ul style="list-style-type: none"> • Traditional: 50, 77, or 200 kHz • DownVü: 260 or 455 kHz

*The device withstands incidental exposure to water of up to 1 m for up to 30 min. For more information, go to www.garmin.com/waterrating.

**Dependent upon transducer rating and depth.

***Maximum depth, dependent upon transducer, water salinity, bottom type, and other water conditions.

****Dependent upon echoMAP model.

Type	Sentence	Description
	VDM	AIS VHF data-link message
You can purchase complete information about National Marine Electronics Association (NMEA) format and sentences from: NMEA, Seven Riggs Avenue, Severna Park, MD 21146 USA (www.nmea.org)		

NMEA 0183 Information

Type	Sentence	Description
Transmit	GPAPB	APB: Heading or track controller (autopilot) sentence "B"
	GPBOD	BOD: Bearing (origin to destination)
	GPBWC	BWC: Bearing and distance to waypoint
	GPGGA	GGA: Global positioning system fix data
	GPGLL	GLL: Geographic position (latitude and longitude)
	GPGSA	GSA: GNSS DOP and active satellites
	GPGSV	GSV: GNSS satellites in view
	GPRMB	RMB: Recommended minimum navigation information
	GPRMC	RMC: Recommended minimum specific GNSS data
	GP RTE	RTE: Routes
	GPVTG	VTG: Course over ground and ground speed
	GPWPL	WPL: Waypoint location
	GPXTE	XTE: Cross track error
	PGRME	E: Estimated error
	PGRMM	M: Map datum
	PGRMZ	Z: Altitude
	SDDBT	DBT: Depth below transducer
	SDDPT	DPT: Depth
	SDMTW	MTW: Water temperature
	SDVHW	VHW: Water speed and heading
Receive	DPT	Depth
	DBT	Depth below transducer
	MTW	Water temperature
	VHW	Water speed and heading
	WPL	Waypoint location
	DSC	Digital selective calling information
	DSE	Expanded digital selective calling
	HDG	Heading, deviation, and variation
	HDM	Heading, magnetic
	MWD	Wind direction and speed
	MDA	Meteorological composite
	MWV	Wind speed and angle

Garmin® and the Garmin logo are trademarks of Garmin Ltd. or its subsidiaries, registered in the USA and other countries. echoMAP™ is a trademark of Garmin Ltd. or its subsidiaries. These trademarks may not be used without the express permission of Garmin.

NMEA® is a registered trademark of the National Marine Electronics Association.