

62 ST Compact Motor™ Electric Above Deck

2 speed manual, variable speed electric, 12VDC

Andersen Powered Winch: RA2062015100

62ST ABOVE DECK COMPACT MOTOR™ ELECTRIC
2 speed manual, variable speed electric, 12VDC

Product Information:

Power Ratio	1st speed = 16.0:1, 2nd speed = 62.6:1
Gear Ratio	1st speed = 3.7:1, 2nd speed = 14.4:1
Maximum Working Load	1500kg (3310lb)
Maximum Pulling Load (when electrically operated)	1380kg (3040lb)

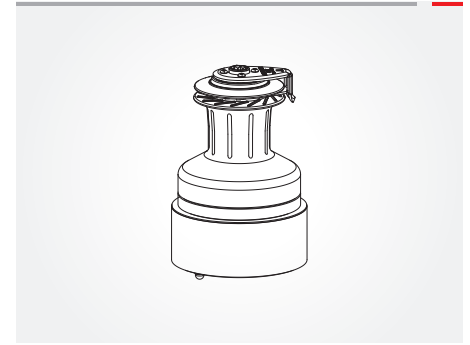

Physical Dimensions:

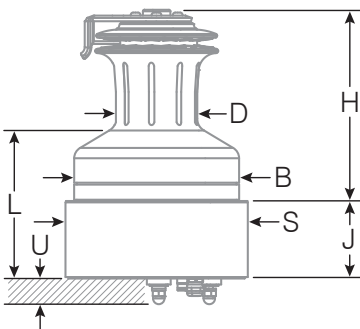

Rope Size	8-18mm (5/16 - 5/8")
Drum Ø D	115mm (4 1/2")
Base Ø B	230mm (9 1/16")
Height H	266mm (10 1/2")
Line Entry L	198mm (7 13/16")
Motor Depth U	28mm (1 1/8")*
Motor Ø S	254mm (10")
Motor Height J	85mm (3 3/8")
Weight	34kg (75lb)

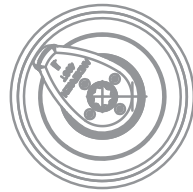

*Extensions available to suit thicker decks.
Full installation dimensions can be found in the Product Manuals - available to download at www.andersenwinches.com

Wiring Diagram:

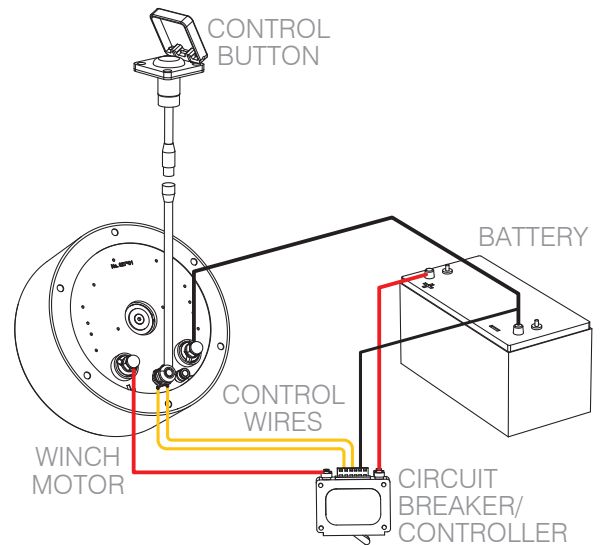

Motor units are supplied with installation manual, control button, 1000mm (39") control button cable, circuit breaker/controller, cable terminals and terminal extensions.

Electrical Installation:

WIRE LENGTH ¹	WIRE SIZE	ADDITIONAL BATTERY CAPACITY PER WINCH ²	MINIMUM BATTERY BANK CAPACITY ³
0-10m (10-33ft)	25mm ²	57Ah	150Ah
10-15m (33-49ft)	35mm ²		
15-20m (49-65ft)	50mm ²		

- Wire length = length from battery to motor and back to battery.
- This is the minimum additional Ah (Ampere hours) battery capacity that will be required to run one winch. Assuming a single winch, used for of 15 minutes (0.25hr) per day at a load of 1/2 MWL = 75A. This equates to an Ah figure of 19Ah. The number of Ah for all other electrical equipment must be added to this figure to determine the Ah requirement of the total battery bank capacity. A good rule of thumb is to use 3 x this total Ah figure as the minimum additional battery capacity for your battery bank. We recommend you contact a qualified marine electrician for advice.
- This is the minimum recommended battery bank capacity to ensure minimum 10.5V is maintained in 12V systems, and 21V in 24V systems at start up current. Based upon battery CCA value at -18C and assuming fully charged batteries and no losses in wiring and connections.

Performance:

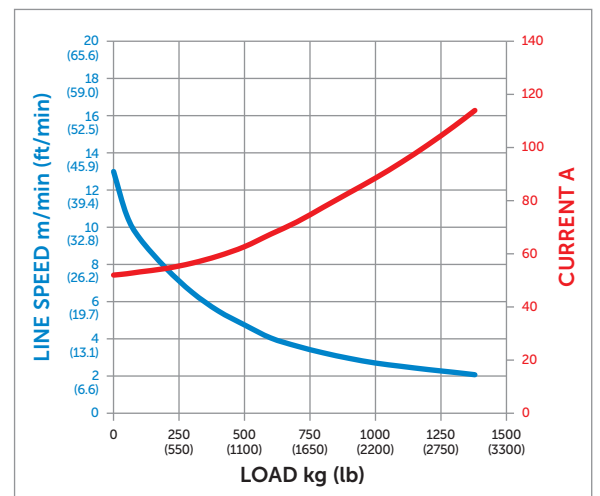

The motor will cut-out at pre-determined current and temperature limits.